

Side-by-Side Refrigerator—Technical Information

JCD2292KT* JCD2292KT*2, JCD2295KE* JCD2295KE*2, JCD2297KE* JCD2297KE*2,
 JSD2695KES JSD2695KES2, JSD2695KG* JSD2695KG*0, JSD2697KE* JSD2697KE*2,
 MSD2660KEG* MSD2660KEG*, MSD2660KES MSD2660KES0

CAUTION

Due to a possibility of personal injury or property damage, always contact an authorized technician for service or repair of this refrigerator. All safety information must be followed as provided in Service Manual 16025628.

WARNING

To avoid risk of electrical shock that can cause death or severe personal injury, disconnect unit from power before servicing unless testing is required. Discharge capacitors through a 10,000 ohm resistor before handling. Wires removed during disassembly must be replaced on correct terminals to ensure proper grounding and polarization.

No-Load Performance, Controls in Normal Position

Ambient °F	Kw/24 hr ±0.4			Percent Run Time ±10%			Cycles/24 hr ±25%			Refrigerator Center Compartment Average Food Temperature ±3°F			Freezer Compartment Average Food Temperature ±3°F		
	70°	90°	110°	70°	90°	110°	70°	90°	110°	70°	90°	110°	70°	90°	110°
22 cu ft	1.2	1.85	2.6	35	55	75	24	24	19	37	39	42	0	0	-2
23 cu ft	1.2	1.85	2.6	35	55	75	24	24	19	37	39	42	0	0	-2
26 cu ft	1.2	1.85	2.6	35	55	75	24	24	19	37	39	42	0	0	-2

Temperature Relationship Test Chart

Ambient °F	Evaporator Outlet ±3°F		Evaporator Inlet ±3°F		Suction Line ±7°F		Average Total Wattage ±10%		Suction Pressure ±2 PSIG		Head Pressure ± 5 PSIG	
	70°	90°	70°	90°	70°	90°	70°	90°	70°	90°	70°	90°
22 cu ft	-15	-15	-16	-16	72	98	132	138	6"(Vac.)	0	87	137
23 cu ft	-19	-15	-20	-16	72	98	132	138	6"(Vac.)	0	95	137
26 cu ft	-15	-15	-16	-16	72	98	132	138	6"(Vac.)	0	87	137

Schematic

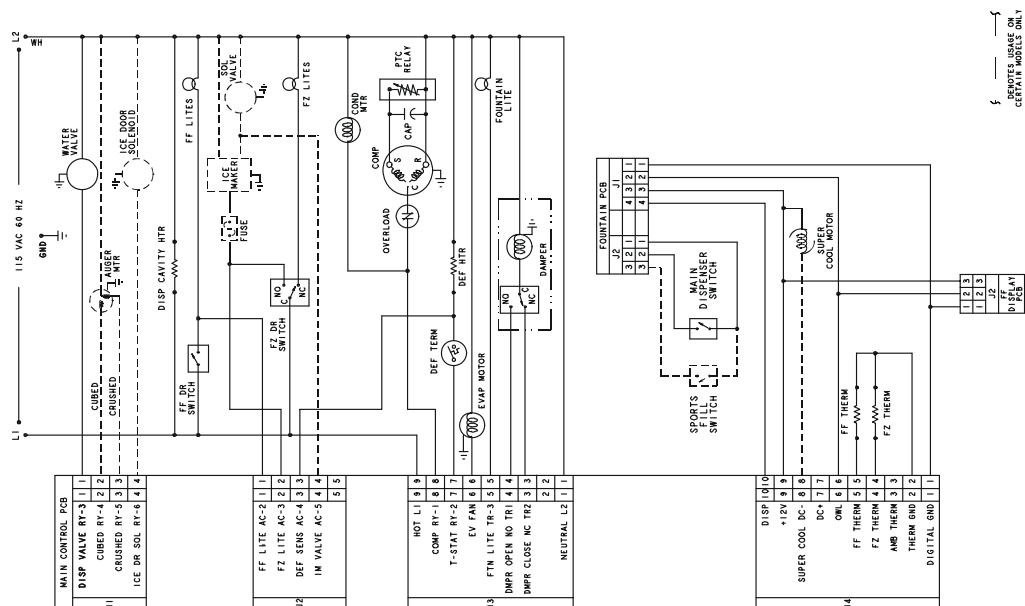

Component Specifications



WARNING

To avoid risk of electrical shock that can cause death or severe personal injury, disconnect unit from power before servicing unless tests require power. Discharge capacitors through a 10,000-ohm resistor before handling. Wires removed during disassembly must be replaced on correct terminals to ensure proper grounding and polarization.

Component	Specifications all parts 115VAC/60HZ unless noted	
Compressor run capacitor	Volt.....	220 VAC
	Capacitance	15 μ fd \pm 10%
Compressor	BTUH	905 BTUH
	Watt	60 Hz / 153 watts
	Current Lock rotor	19.0 amps \pm 15%
	Current Full load	1.26 amps \pm 15%
	Resistance Run windings.....	3.33 ohms \pm 15%
	Resistance Start windings.....	4.28 ohms \pm 15%
Electric damper control	Maximum closing time	8 seconds
	Temperature Rating	20°F- 110°F
	RPM	5
Thermistor	Temperature	Resistance
	77°F.....	10,000 ohms \pm 1.8%
	36°F	29,500 ohms \pm 1.0%
	0°F.....	86,300 ohms \pm 1.8%
Condenser motor	Rotation (facing end opposite shaft)	Clockwise
	RPM.....	1120 RPM
	Watt.....	3.4 watts \pm 15% @ 115VAC
	Current	0.085 amps \pm 15% @ 115VAC
Evaporator fan motor	Rotation (facing end opposite shaft)	Clockwise
	RPM.....	2800 RPM
	Watt.....	6.0 \pm 15% watts @ 115 VAC
	Note: Fan blade must be fully seated on shaft to achieve proper airflow.	
Overload/Relay	Ult. trip amps @ 158°F (70°C)	2.40 amps \pm 15%
	Close temperature	140°F \pm 10°
	Open temperature	230°F \pm 5°
	Short time trip (seconds).....	17 seconds \pm 5
	Short time trip (amps @ 77°F (25°C))..	12 amps \pm 2amps
Thermostat (Defrost)	Volt	120/240 VAC
	Watt	475 watts
	Current	10/5 amps
	Resistance across terminals:	
	Above 42°F \pm 5°	Open
	Below 12°F \pm 7°	Closed
Evaporator heater 22 & 26 cu. ft	Volt.....	115 VAC
	Wattage	450 \pm 5% watts @ 115VAC
	Resistance	29 \pm 5% ohms
Evaporator heater 23 cu. ft	Volt.....	115 VAC
	Wattage	350 \pm 5% watts @ 115VAC
	Resistance	37.8 \pm 5% ohms
Control board	Volt.....	120VAC, 60 HZ
	See Control board troubleshooting section.	
Auger Motor	Rotation (facing end opposite shaft)	Power to blue and white is clockwise. Power to orange and white is counterclockwise.
	RPM.....	17 \pm 3 RPM
Water Valve	Watts.....	Brown side 35w, Yellow side 20w
Super Cool Fan	Rotation (facing end opposite leads)	Counterclockwise
	RPM.....	1530 \pm 250
	Watt.....	1.2 @ 12 VDC
Light switch / Interlock	Type.....	SPDT NO/NC
	Volt.....	125/250 VAC
	Current.....	8/4 amps
Solenoid (Ice Chute)	Resistance across leads.....	101ohms \pm 10%

Service Specifications





WARNING

To avoid risk of electrical shock that can cause death or severe personal injury, disconnect unit from power before servicing unless tests require power. Discharge capacitors through a 10,000-ohm resistor before handling. Wires removed during disassembly must be replaced on correct terminals to ensure proper grounding and polarization.

Programming Mode:

NOTE: The Program Code is located on the Serial Plate on this unit after the word Code.



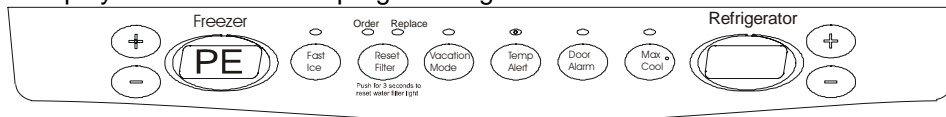

1. Open the Fresh Food door and press and hold the Door Alarm Keypad .
2. Press and hold Freezer Temperature Down Keypad .
3. Release the Door Alarm Keypad  and wait 3 seconds.
4. The control will display PE to indicate the programming mode.

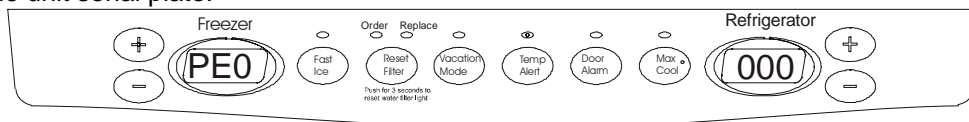

5. Entry is confirmed by pressing the Freezer Temperature Down Keypad  once more.
6. The control will display the current Program CODE. This value should be validated with the Program CODE printed on the unit serial plate.



NOTE: If the Program CODE is correct, the Programming Mode is exited by closing the Refrigerator door(s).

7. Press the Refrigerator Temperature Up Keypad  or Refrigerator Down Keypad  to change the digit value with each key press.
8. The decimal point indicates the selected digit. Press the Freezer Temperature Up Keypad  to select the next digit.
9. Once the desired Program CODE is displayed, press and hold the Freezer Temperature Down Keypad  until the Program CODE begins flashing indicating it has been saved.

NOTE: If you attempt to enter an invalid Program CODE the control will not save the new code, but will beep. (The unit will NOT run with a Program CODE of 0000). Once the Program CODE has been saved the Programming Mode is exited by closing the Refrigerator door(s). If the new code is incorrect this process should be repeated after closing the Refrigerator door(s).

The Programming mode can be exited at any time by closing the Refrigerator Door(s) or will exit if unattended for four minutes.

Defrost Operation:

The Control Board adapts the compressor run time between defrosts to achieve optimum defrost intervals by monitoring the length of time the defrost heater is on. After initial power up, defrost interval is 4 hours compressor run time. Defrost occurs immediately after the 4 hours.

Service Specifications





WARNING

To avoid risk of electrical shock that can cause death or severe personal injury, disconnect unit from power before servicing unless tests require power. Discharge capacitors through a 10,000-ohm resistor before handling. Wires removed during disassembly must be replaced on correct terminals to ensure proper grounding and polarization.

Forced Defrost Mode:

The forced defrost function is performed using the Freezer display and Refrigerator keypad. Enter the Forced Defrost Mode by performing the following sequence of events:

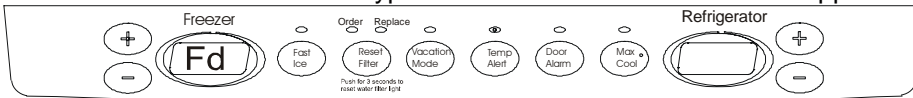

1. Open the Fresh Food door and press and hold the Door Alarm Keypad .
2. Press and hold Refrigerator Temperature Down Keypad .
3. Release the Door Alarm Keypad  and wait 3 seconds. Fd appears in left display.







4. Press the Refrigerator Down Keypad  again. SH appears in right display.
5. Press again to force defrost, Fd and SH will flash in display indicating unit is in defrost.

Service Test Mode:

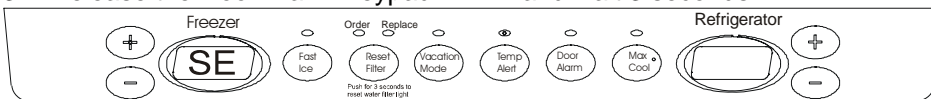

The service test functions are performed using the refrigerator display and keypad. Enter the Service Test Mode by performing the following sequence of events:

1. Open the Fresh Food door and press and hold the Door Alarm Keypad .
2. Press and hold Refrigerator Temperature Up Keypad .
3. Release the Door Alarm Keypad  and wait 3 seconds.





4. Press the Refrigerator Down Keypad  again.
5. Display will show 001 in left display and numeric or dashes in right display.
6. Press Freezer Up Keypad  and Freezer Down Keypad  to toggle through Service Test numbers.



Service Test – 101 Defrost Heater & Defrost Circuit

- Press the Refrigerator Up keypad  and Refrigerator Down keypad  to energize or de-energize the Defrost circuit. The display will read OFF when de-energized, OP when energized with open defrost thermostat, and CL when energized with closed defrost thermostat.

Service Test – 102 Compressor / Condenser Fan

- Press the Refrigerator Up keypad  and Refrigerator Down keypad  to toggle Compressor/Condenser fan On and Off.

Service Test – 111 Fresh Food Fan (if equipped)

- Press the Refrigerator Up Keypad  and Refrigerator Down Keypad  to toggle Fresh Food Fan On and Off.

NOTE: Display will show state OFF or DC voltage.



Service Specifications





WARNING

To avoid risk of electrical shock that can cause death or severe personal injury, disconnect unit from power before servicing unless tests require power. Discharge capacitors through a 10,000-ohm resistor before handling. Wires removed during disassembly must be replaced on correct terminals to ensure proper grounding and polarization.



Service Test – 112 Freezer Fan

- Press the Refrigerator Up Keypad  and Refrigerator Down Keypad  to toggle Freezer Fan On and Off.
NOTE: Display will show state OFF or DC voltage.

Service Test – 121 Damper Operation

- Press the Refrigerator Up Keypad  and Down keypad  to toggle Damper (OP) open and (CL) closed.
NOTE: If damper is opening or closing it will not allow you to toggle damper and beep. Display will show state –CL or –OP if Damper is in the process of closing or opening.

Service Test – 131 (3) Door Bottom Freezer Mullion Heater

- Press the Refrigerator Up Keypad  and Refrigerator Down Keypad  to toggle Mullion Heater Off and On.

Service Test – 141 Fresh Food Thermistor

- Will Show Fresh Food Temperature or OP for open thermistor or SH for shorted thermistor.

Service Test – 142 Freezer Thermistor

- Will Show Freezer Temperature or OP for open thermistor or SH for shorted thermistor.

Service Test – 143 Machine Compartment Thermistor

- Will Show Machine Compartment Temperature or OP for open thermistor or SH for shorted thermistor.

Service Test – 151 Fresh Food Door State

- Will show state of Fresh Food Door. OP (open) CL (closed).

NOTE: By pushing fresh food door switch you can toggle state from OP (open) to CL (closed).

Service Test – 152 Freezer Food Door State

- Will show state of Freezer Door. OP (open) CL (closed).

NOTE: By pushing freezer door switch you can toggle state from OP (open) to CL (closed).

Service Test – 161 Cube Dispenser (if equipped)

- Display shows the state of the Cube Dispenser (ON or OFF).

NOTE: By pushing Actuator pad you can control state of cube dispenser without opening Ice Chute door.

Service Test – 162 Crusher Dispenser (if equipped)

- Display shows the state of the Crusher Dispenser (ON or OFF).

NOTE: By pushing Actuator pad you can control state of Crusher dispenser without opening Ice Chute door.

Service Test – 163 Water Dispenser (if equipped)

- Display shows the state of the Water Dispenser (ON or OFF).

NOTE: By pushing Actuator pad or Bottle fill you can control state of Water dispenser.

Service Specifications



WARNING

To avoid risk of electrical shock that can cause death or severe personal injury, disconnect unit from power before servicing unless tests require power. Discharge capacitors through a 10,000-ohm resistor before handling. Wires removed during disassembly must be replaced on correct terminals to ensure proper grounding and polarization.

Service Test – 164 Ice Chute Dispenser (if equipped)

- Display shows the state of the Ice Chute dispenser (ON or OFF).

NOTE: By pushing Actuator Pad you can control state of Ice Chute Dispenser.

Service Test – 165 Dispenser Lamp (if equipped)

- Display shows the state of the Dispenser Lamp (ON or OFF).

NOTE: By pushing Actuator Pad or Bottle Fill you can control state of dispenser lamp.

Service Test – 171 Actuator Pad (if equipped)

- Display shows the state of the Actuator Pad (ON or OFF).

Service Test – 172 Sports Fill (if equipped)

- Display shows the state of the Sports Fill (ON or OFF).

Service Test – 173 Ambient Light (if equipped)

- Display shows light sensor measurement (Hi or Lo). Night light will turn on if light sensor measures Lo. By changing the sensor's exposure to ambient light you can control the sensor measurement.

Service Test – 174 Water Actuator Bottom Mount Internal Dispenser (if equipped)

- Display shows the state of the Water Valve (ON or OFF).

NOTE: By pushing Water Actuator you can control state of Water Valve On or Off.

Service Test – 175 Dispenser Line (if equipped)

- Display shows the state of the Dispenser Line (ON or OFF).

NOTE: By pushing Actuator pad or Bottle fill you can change state of Dispenser Line.

Service Test – 181 Keypad Operation

- Display shows a numeric or letter display indicating the last key pressed.

NOTE: Refrigerator Up/Down keypads have no effect when pressed and Freezer Up/Down keypads remain operational.

Service Test – 182 LED Indicator Operation

- Press the Refrigerator Up Keypad  to show operation of LED Indicators. All LED Indicators will flash. Press twice and LED will stop flashing.

Service Test – 191 Ice Maker Water Valve

- Display shows the state of the Ice Maker Water Valve (ON or OFF).



Service Specifications





WARNING

To avoid risk of electrical shock that can cause death or severe personal injury, disconnect unit from power before servicing unless tests require power. Discharge capacitors through a 10,000-ohm resistor before handling. Wires removed during disassembly must be replaced on correct terminals to ensure proper grounding and polarization.



Service Test – 201 Mullion Heater Override (if equipped)

- Press the Refrigerator Up Keypad  or Refrigerator Down Keypad  to change Mullion Heater from cycling on with compressor (Off position) to 100% operation (On Position).



Service Test – 202 Default Defrost Operation

- Press the Refrigerator Up Keypad  or Refrigerator Down Keypad  to change Defrost Operation from normal adaptive defrost (Off position) to minimum time between defrosts (On position).

Service Test – 203 Show Temperature Set points



- Press the Refrigerator Up Keypad  or Refrigerator Down Keypad  to change from showing actual temperature (Off position) to show temperature set points only (On position).

Service Test – 211 Fresh Food Temperature Adjustment

- Press the Refrigerator Up Keypad  or Down Keypad  to change calibration of Fresh Food Temperature plus or minus in 1°F increments up to $\pm 6^{\circ}\text{F}$.



NOTE: Temperature will read in Fahrenheit regardless of what current temperature scale is being used.

Service Test – 212 Freezer Temperature Adjustment

- Press the Refrigerator Up Keypad  or Down Keypad  to change calibration of Freezer Temperature plus or minus 1°F in increments up to $\pm 6^{\circ}\text{F}$.

NOTE: Temperature will read in Fahrenheit regardless of what current temperature scale is being used.

Service Test – 221 Reset Default Settings

Press the Refrigerator Up Keypad  and Down Keypad  to force to dEF (default factory settings).
closed.

