

GE Consumer & Industrial

Technical Service Guide

DECEMBER 2005

GE Dryer

DBVH512
DCVH515
DHDVH52

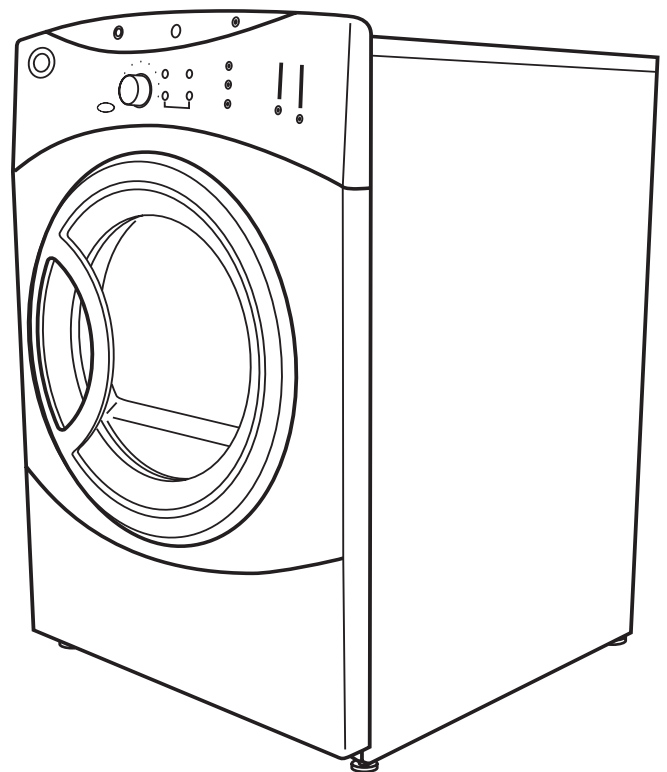

31-9136



GE Appliances
General Electric Company
Louisville, Kentucky 40225



IMPORTANT SAFETY NOTICE

The information in this service guide is intended for use by individuals possessing adequate backgrounds of electrical, electronic, and mechanical experience. Any attempt to repair a major appliance may result in personal injury and property damage. The manufacturer or seller cannot be responsible for the interpretation of this information, nor can it assume any liability in connection with its use.

WARNING

If the information in this manual is not followed exactly, fire or explosion may result causing property damage, personal injury or death. If you smell gas:

- Do not try to light any appliance.
- Do not touch any electrical switch; do not use any phone in the building.
- Immediately call the gas supplier from a neighbor's phone. Follow the gas supplier's instructions.
- If you cannot reach the gas supplier, call the fire department.

WARNING

To avoid personal injury, disconnect power before servicing this product. If electrical power is required for diagnosis or test purposes, disconnect the power immediately after performing the necessary checks.

RECONNECT ALL GROUNDING DEVICES

If grounding wires, screws, straps, clips, nuts, or washers used to complete a path to ground are removed for service, they must be returned to their original position and properly fastened.

GE Consumer & Industrial
Technical Service Guide
Copyright © 2005

All rights reserved. This service guide may not be reproduced in whole or in part in any form without written permission from the General Electric Company.

Table of Contents

Airflow	23
Air Duct Assembly	42
Belt Switch	34
Blower Housing.....	34
Component Locator Views.....	24
Control Board Assembly	44
Control Panel	28
Control Features.....	6
Cycle Options.....	9
Door Switch	42
Drive Belt.....	29
Drum.....	30
Drum Shaft Bearing.....	31
Drum Slide Assembly.....	41
Dryer Components	28
Dryer Features	11
Error Codes	47
Flame Detector	37
Front Panel.....	29
Gas Valve	35
Gas Valve Coil Assembly	36
Heater Assembly.....	35
High Limit Thermostat.....	40
Idler Assembly.....	31
Ignitor	37
Ignitor Circuit Operation	38
Inlet Control Thermistor	39
Inlet Safety Thermostat.....	39
Introduction.....	5
LP Conversion	36
Moisture Sensor	43
Motor and Blower Wheel Assembly.....	32
Nomenclature	4
Operation Overview.....	22
Outlet Control Backup Thermostat.....	41
Outlet Control Thermistor	40
Pedestal Installation (Washer and Dryer).....	16
Power Board.....	43
Reversing the Door Swing	12
Schematics and Wiring Diagrams	48
Service Test Mode.....	45
Stacking Instructions	19
Top Panel	28
Warranty	50

Nomenclature

Model Number

D C V H 5 1 5 E F 0 W W

Brand

D = General Electric

Feature Packages

B = Base

C = Contract/HPS

HD = Brand Feature Pack

Capacity/Configuration

V = Very Big

Backsplash Control/Platform

H = Horizontal

Control Features

Color

WW - White

GG - Granite

Engineering Revision Alpha or Numeric

Model Year

F - 2005

G - 2006

H - 2007

J - 2008

K - 2009

Fuel/Voltage

E = 220V/208V 60 Hz.

G = Gas 120V 60Hz.



Nomenclature

The nomenclature tag is located on the front panel inside the door.

Note: The technical sheet is located inside the control panel.

Serial Number

The first two characters of the serial number identify the month and year of manufacture.

Example: **AH123456S** = January, 2005

A - JAN	2005 - H
D - FEB	2004 - G
F - MAR	2003 - F
G - APR	2002 - D
H - MAY	2001 - A
L - JUN	2000 - Z
M - JUL	1999 - V
R - AUG	1998 - T
S - SEP	1997 - S
T - OCT	1996 - R
V - NOV	1995 - M
Z - DEC	1994 - L

The letter designating the year repeats every 12 years.

Example:

T - 1974
T - 1986
T - 1998

Introduction

The new GE dryer has the following features:

- Large 7.0-cubic foot dryer drum
- Drying Rack - Available on some models, for drying delicate items such as washable sweaters.
- Drum Lamp
- My Cycle selection saves a favorite cycle for future use.
- Built-in service test mode. Specific dryer components can be operated. Error codes are recorded and accessible on the control panel's 7-segment display.
- Dual Thermistors - Thermistors are more sensitive to temperature changes and can relay the information faster than thermostats. The dryer utilizes dual thermistors to monitor incoming air temperature as well as air temperature leaving the drum. The sensors work together with the variable heater and the blower to provide consistent, even heat.
- Moisture Sensor - The moisture sensor allows the control to monitor the fabric for moisture content and end the cycle at the desired moisture level.
- Flush Door Handle
- Reversible Door
- UV Stabilizers - The control panel, control panel cover, and door outer panel have UV stabilizers to prevent yellowing when exposed to sunlight.
- The GE dryer can be installed on top of the GE Front Load Washer. (Stacking kit supplied with washer.)
- Pedestal available at additional cost. White (model number SBS227FWW) and granite (model number SBS227FGG).



Control Features

Model DBVH512

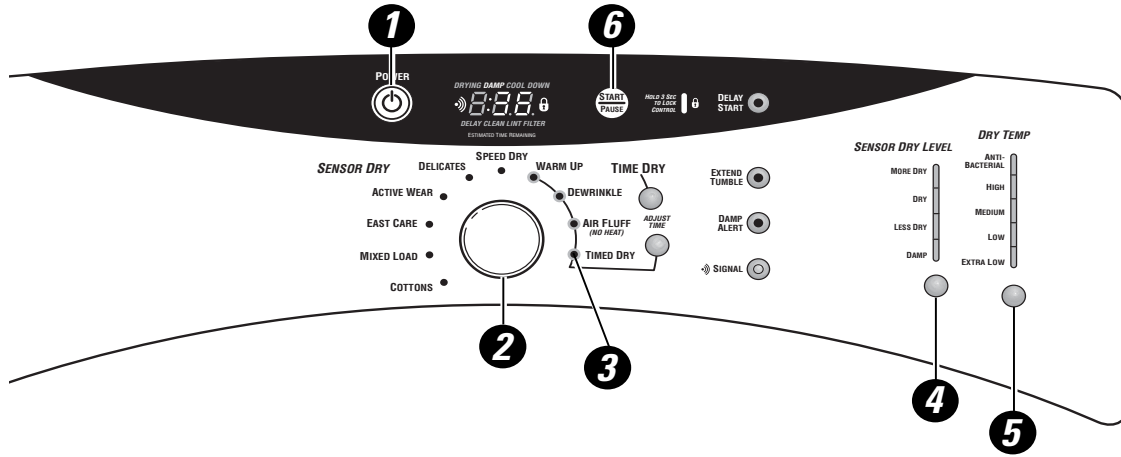

Model DCVH515

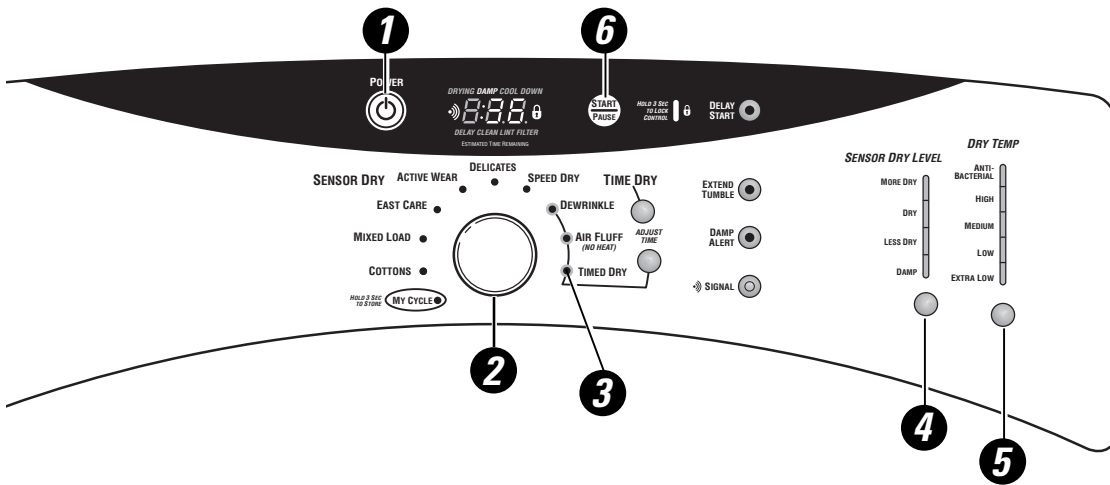

Model DHDVH52

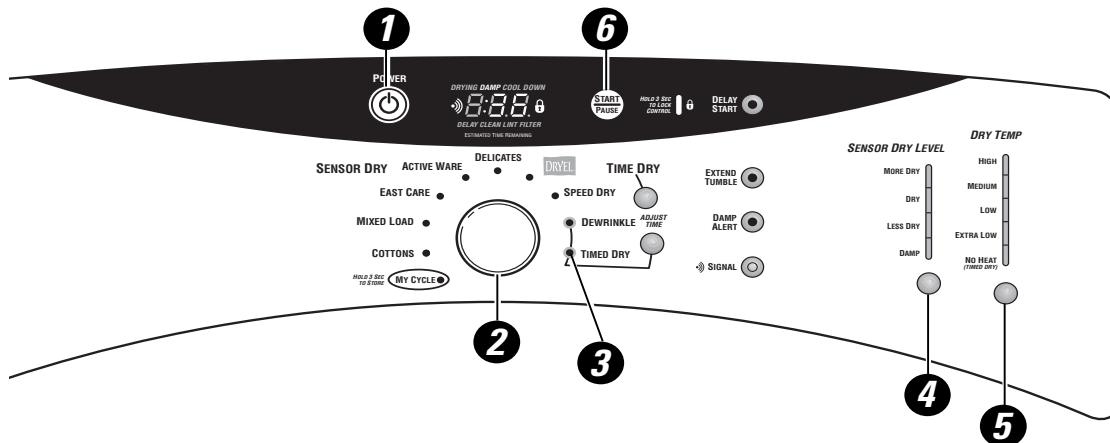

1**Power**

Press to “wake up” the display. If the display is active, press to put the dryer in the standby mode.

NOTE: Pressing **POWER** does not disconnect the appliance from the power supply.

2**Dry Cycles**

The dry cycle controls the length and tumble speed of the drying process. The chart below will help you match the dry setting with the loads.

Sensor Cycles

COTTONS	For cottons and most linens.
MIXED LOAD	For loads consisting of cottons and poly-blends.
EASY CARE	For wrinkle-free and permanent press items.
ACTIVE WEAR	Clothing worn for active sports exercise and some casual wear. Fabrics include new technology finishes and stretch fibers such as Spandex.
DELICATES	For lingerie and special-care fabrics.
DRYEL™	Designed for use with the DRYEL™ “dry clean only” fabric care system. See product package for directions. For questions or issues related to use and performance of DRYEL™, see the Website at: www.dryel.com .
SPEED DRY	For small loads that are needed in a hurry, such as sports or school uniforms. Can also be used if the previous cycle left some items damp, such as collars or waistbands.

Timed Dry Cycles

DEWRINKLE	For removing wrinkles from items that are dry or slightly damp. This cycle is not recommended for delicate fabrics.
WARM UP	Provides 10 minutes of warming time to warm up clothes.
AIR FLUFF	Use this feature to tumble items without heat.

My Cycle (on some models)

MY CYCLE	Press to use, create or modify custom dry cycles.
-----------------	---

3**Timed Dry**

Use to set your own dry time. **TIMED DRY** is also recommended for small loads.

To use TIMED DRY:

1. Turn dry cycle dial to **TIMED DRY**.
2. Select the drying time by pressing the **+** and **-** buttons.
3. Select the **DRY TEMP**.
4. Close the door.
5. Press **START**.

4**Sensor Dry Level**

The sensor continuously monitors the amount of moisture in the load. When the moisture in your clothes reaches your selected dry level, the dryer will stop.

MORE DRY	Use for heavy or mixed type of fabrics.
DRY	Use for normal dryness level suitable for most loads. This is the preferred cycle for energy saving.
LESS DRY	Use for lighter fabric (ideal for ironing).
DAMP	For leaving items partially damp.

5 **Dry Temp**

You can change the temperature of your dry cycle.

ANTI-BACTERIAL This option may only be used with **COTTONS** or **MIXED LOAD** cycles. This option reduces certain types of bacteria by 99.9%, including: *Staphylococcus aureus*, *Pseudomonas aeruginosa* and *Klebsiella pneumoniae**. The anti-bacterial process occurs when high heat is used during a portion of this drying cycle.

NOTE: Do not use this cycle on delicate fabrics.

* The Anti-Bacterial Cycle is Certified by NSF International (formerly National Sanitation Foundation) to NSF Protocol *P154 Sanitization Performance of Residential Clothes Dryers*.



NSF Protocol P154
Sanitization Performance of
Residential Clothes Dryers

HIGH	For regular to heavy cottons.
MEDIUM	For synthetics, blends and items labeled permanent press.
LOW	For delicates, synthetics and items labeled <i>Tumble Dry Low</i> .
EXTRA LOW	For lingerie and special-care fabrics.
NO HEAT	Can only be used with TIMED DRY .

6 **START**

Press to start a dry cycle. If the dryer is running, press it once and it will pause the dryer. Press it again to restart the dry cycle.

My Cycle (on some models)

Set up your favorite combination of settings and save them here for one touch recall. These custom settings can be set while a cycle is in progress.

To store a MY CYCLE combination of settings:

1. Select your drying cycle.
2. Change **DRY TEMP** and **SENSOR DRY LEVEL** settings to fit your needs.
3. Select any drying **OPTIONS** you want.
4. Press and hold the  pad for three seconds to store your selection. A beep will sound and the pad will light up.

To recall your stored MY CYCLE combination:

Press the **MY CYCLE** button before drying a load.

To change your stored MY CYCLE combination:

Follow steps 1–4 in “**To store a MY CYCLE combination of settings**”.

**EXTEND
TUMBLE**



Extend Tumble

Minimizes wrinkles by adding approximately 60 minutes of no-heat tumbling after clothes are dry. The beeper will sound every 2 minutes to remind you to remove the clothes. The **ESTIMATED TIME REMAINING** display will show **00**.

**DAMP
ALERT**



Damp Alert

This option causes the dryer to beep when clothes have dried to a damp level. Remove items that you wish to hang dry. The **DAMP ALERT** will only beep when this option is selected.

Removing clothes and hanging them when they are damp can reduce the need to iron some items.

SIGNAL



Signal

Alerts you that the cycle is complete. The beeper will continue to sound every two minutes for the next 6 minutes, until the clothes have been removed. The clothes should be removed when the beeper goes off so wrinkles don't set in.

Press **SIGNAL** to select low, medium or high volume, or to turn the beeper off.

**DELAY
START**



Delay Start

Use to delay the start of your dryer.

1. Choose your dry cycle and any options.
2. Press **DELAY START**. You can change the delay time in 1 hour increments using the **+** or **-** arrow pads.
3. Press the **START** pad to start the countdown.

The countdown time will be shown in the **ESTIMATED TIME REMAINING** display.

NOTE: If the door is opened while the dryer is in **DELAY**, the countdown time will not restart unless the door is closed and **START** has been pressed again.

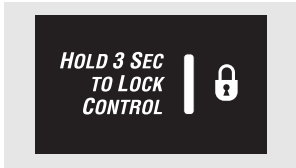

Lock

You can lock the controls to prevent any selections from being made. Or you can lock the controls after you have started a cycle.

Children cannot accidentally start the dryer by touching pads with this option selected.

To lock the dryer, press and hold the lock icon for 3 seconds. To unlock the dryer, press and hold the lock icon for 3 seconds.

The icon of the lock next to the timer will light up when the controls are locked.

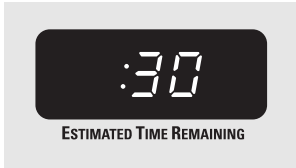

Estimated Time Remaining

Displays the approximate time remaining until the end of the cycle.

As the cycle begins, you will see an initial approximate total cycle time in the display. Then lights will “race” in the display. This means the dryer is continuously monitoring the amount of moisture in the load. The lights will continue until the dryer senses a low level of moisture in the load. At that point, the dryer will calculate and display the approximate time remaining.



My Cycle (on some models)

To save a favorite cycle, set the desired settings and hold down the **MY CYCLE** button for 3 seconds. A beep will sound to indicate the cycle has been saved.

To use your custom cycle, press the **MY CYCLE** button before drying a load.

To change the saved cycle, set the desired settings and hold down the **MY CYCLE** button for 3 seconds.

See page 8 for more details.

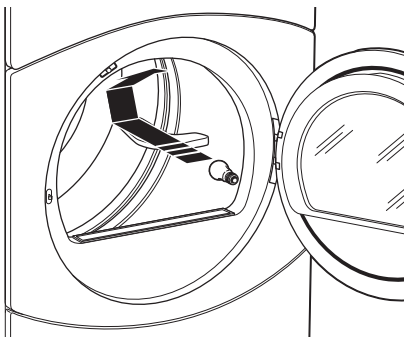

Drum Lamp

Before replacing the light bulb, be sure to unplug the dryer power cord or disconnect the dryer at the household distribution panel by removing the fuse or switching off the circuit breaker. Reach above dryer opening from inside the drum. Remove the bulb and replace with the same size bulb.

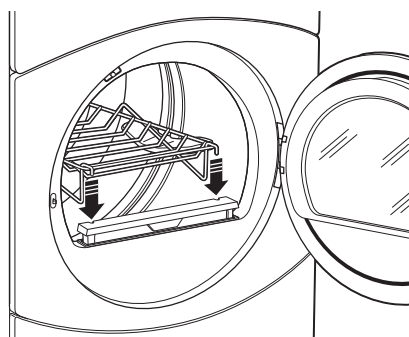

Drying Rack (on some models)

A handy drying rack may be used for drying delicate items such as washable sweaters. Place items flat on the drying rack and block such items as wool sweaters and delicate fabrics. Dry with low heat.

To install the drying rack, pull up the lint filter slightly. Insert the drying rack into the slots, then push the filter back down.

NOTE:

- The drying rack must be used with the **TIMED DRY** or **RACK DRY** (on some models) cycles.
- Do not use this drying rack when there are other clothes in the dryer.

Reversing the Door Swing

When viewed from the front, the dryer is shipped so the door opens from the left. Due to utility configurations or customer preferences, the door can be set up to open from the right by reversing the door swing.

Note: These instructions are for changing the dryer so the door opens from the right side. To change the door back so that it opens from the left side, follow these same instructions and reverse all references to left and right.

Tools Needed



Phillips Head
Screwdriver

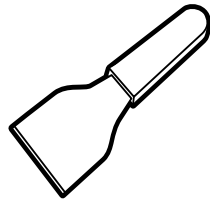

Putty Knife or Thin-
Blade Screwdriver

Door Parts

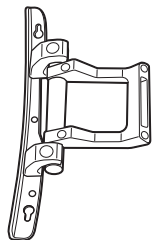

Hinge
Assembly



Hinge
Cover



Window
Retainer

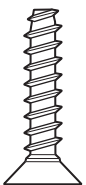

Large Tapping
Screw (#10) - 6



Tapping
Screw (#8) - 2



Machine
Screw (#8) - 6

To reverse the door swing:

1. Unplug the dryer from its electrical outlet.
2. Open the door to approximately 90 degrees. Starting from the bottom to the top, remove the bottom 4 Phillips-head screws from the hinge.

Note: Make sure the door is supported while removing the screws.

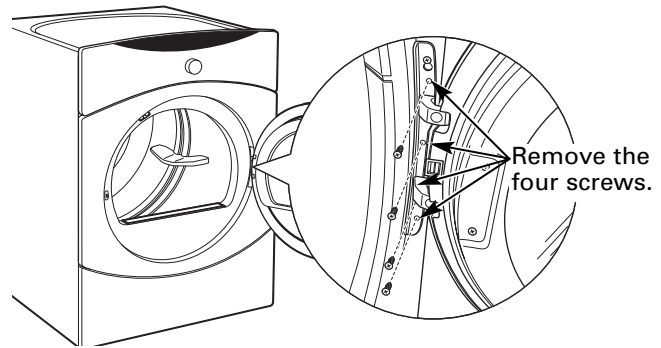

Note: To ease removal of the door, the hinge has a keyhole that allows a partially loosened screw to be used as a hook.

3. Loosen the top Phillips-head screw, then lift and unhook the door from the front panel. Remove the top screw.

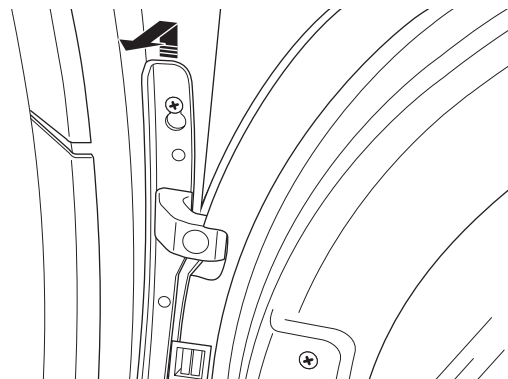

4. Lay the door on a soft protected flat surface so that the inside faces upward (door resting on the handle side).

- Remove the 6 large tapping screws (#10) located around the perimeter of the door outlining the gasket and the 4 machine screws (#8).

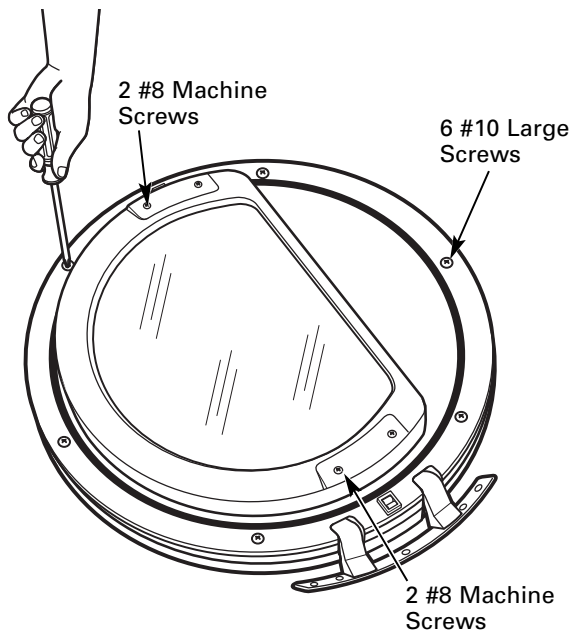

- Turn the door over, separate the door cover from the door frame and set the cover aside.

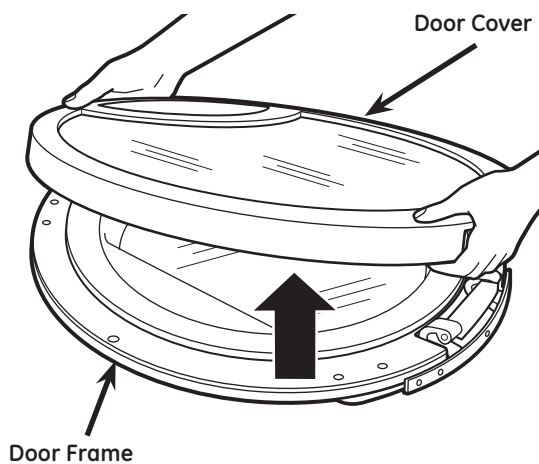

IMPORTANT: Note the location of the hinge (left or right) before removing.

Note: The hinge cover is located at the opposite side of the hinge assembly.

- Turn the door over. Remove the 2 (#8) tapping screws and the hinge cover from the frame.

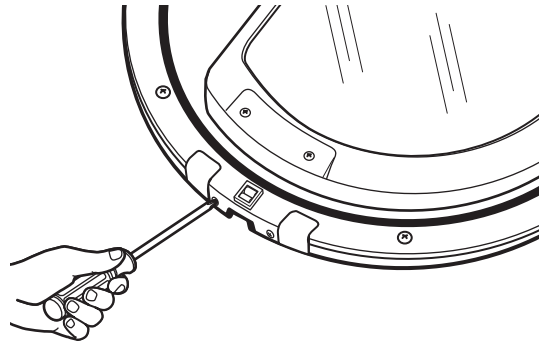

- Remove the window retainer located on the side opposite the hinge assembly and underneath the plastic cover.

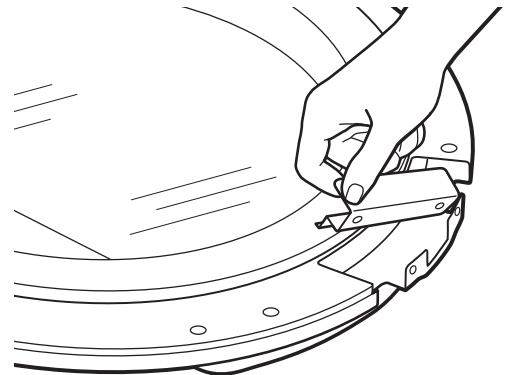

- Remove the 2 (#8) machine screws that attach the hinge assembly to the side of the door frame. Pull the hinge assembly out of the opening in the door.

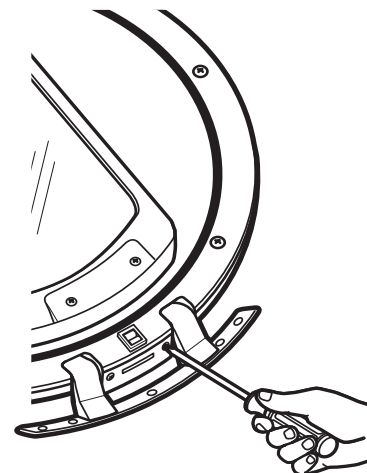

10. Insert the hinge assembly in the opening on the opposite side of the door.

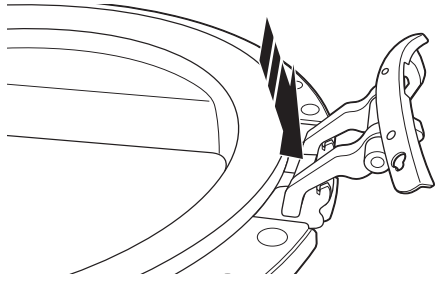

11. Push the hinge assembly into place until the hinge holes align with the door frame holes.

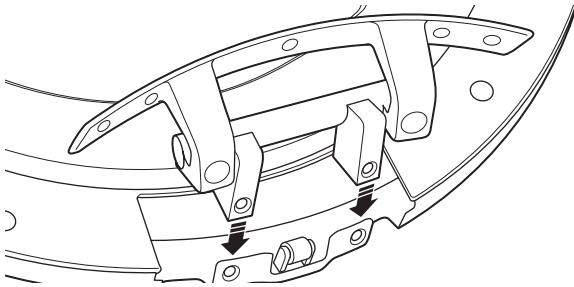

12. Install the 2 (#8) machine screws that attach the hinge assembly to the side of the door frame.

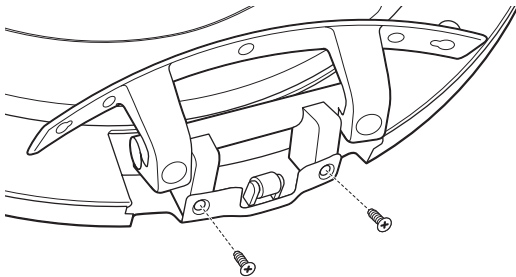

13. Hold the door on its side with one hand and install 2 (#8) machine screws that secure the hinge assembly to the door frame.

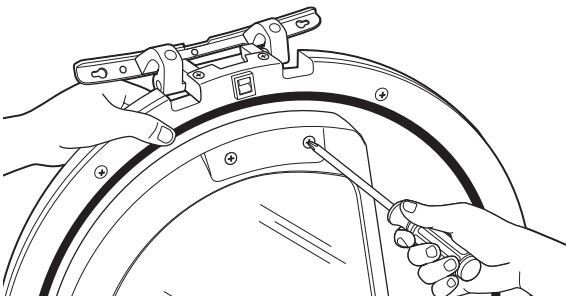

14. Place the door flat and insert the window retainer. Align the window retainer holes with the holes in the door frame.

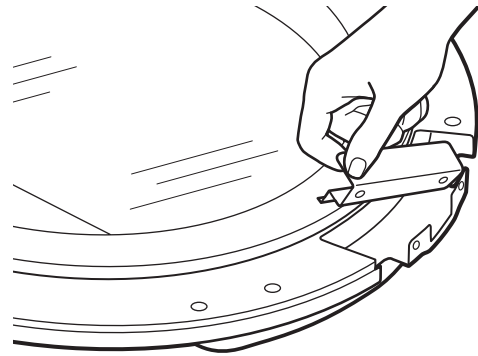

15. Place the door on its edge. Install the remaining 2 (#8) machine screws that attach the window retainer to the door frame.

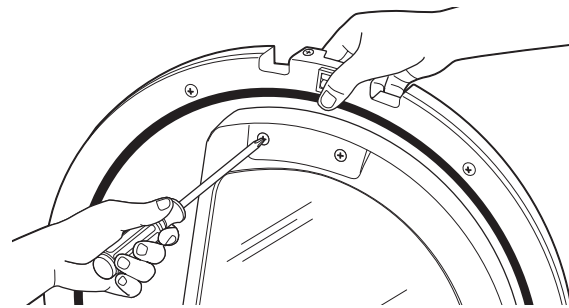

16. Insert and align the hinge cover with the holes in the door frame.

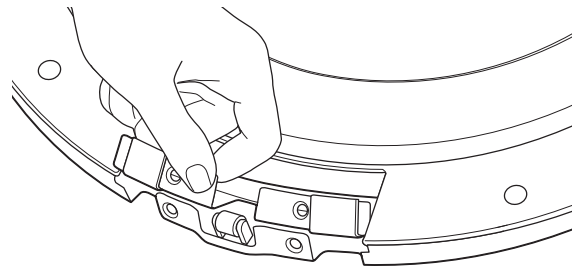

17. Install the 2 (#8) tapping screws that attach the hinge cover to the door frame.

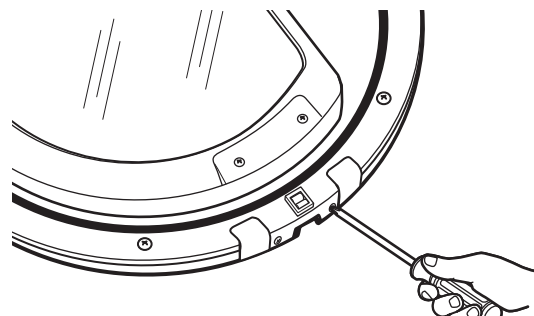

IMPORTANT: Make sure there is no dirt or any other foreign material in between the window panes.

18. Place the door cover onto the door frame.

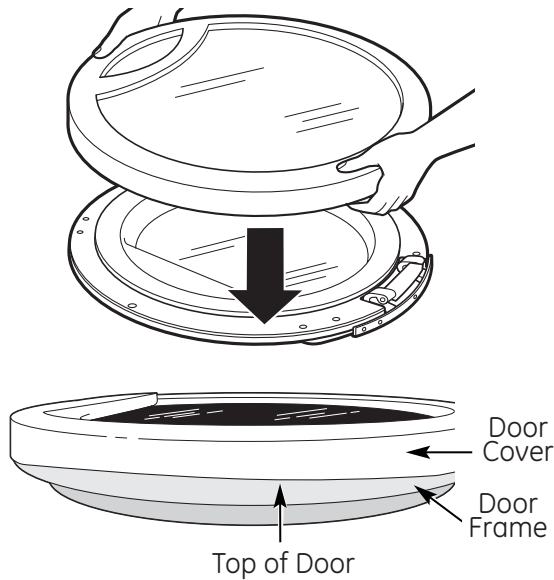

After reversing the door, there will be a mismatch between the door cover and door frame.

Make sure that the handle part of the door cover is opposite the hinge as shown.

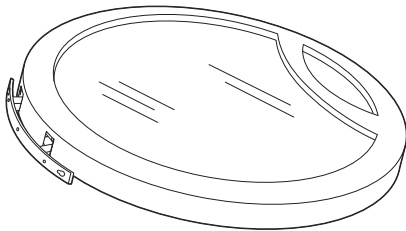

19. Turn the door over. Install the 6 (#10) tapping screws that attach the door cover to the door frame.

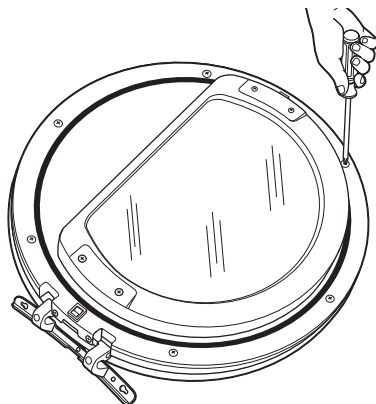

20. Using a putty knife or flat tool, remove the 5 plastic screw caps located near the strike bracket on the front panel. Install the caps on the opposite side.

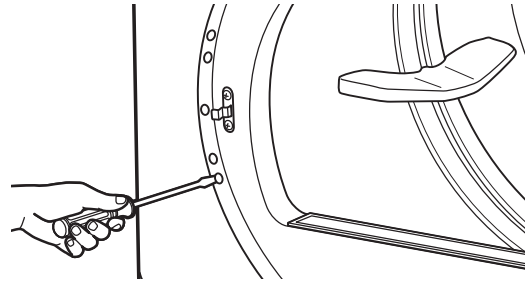

21. Remove the 4 Phillips-head screws that attach the strike bracket and cover to the front panel. Reinstall both on the opposite side.

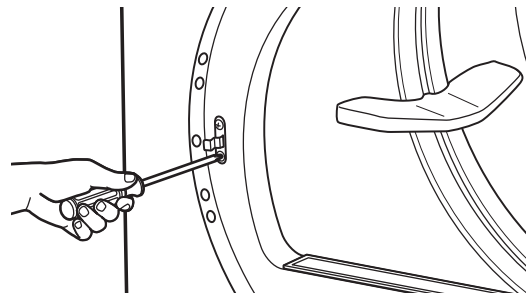

Note: To ease installation of the door, the hinge has a keyhole that allows a partially fastened screw to be used as a hook.

22. Partially fasten a Phillips-head screw to the uppermost screw hole. Hook the door on the partially fastened screw.

23. Fasten the hinge by installing the remaining 4 Phillips-head screws and tightening the partially fastened top screw.

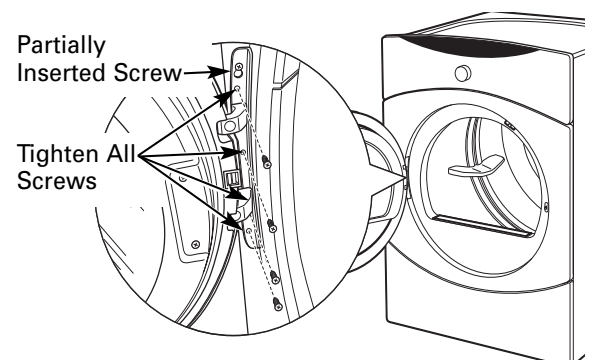

24. Plug the dryer into its electrical outlet.

Pedestal Installation (Washer and Dryer)

Optional 12-inch high storage drawer pedestals with dividers are available to provide convenience and extra storage space for detergent, dryer sheets and other cleaning supplies. The pedestal installation kit includes 4 support pads, 4 mounting screws, and 4 leveling legs with locknuts.

Kit Contents

4 Support Pads



4 Mounting Screws



4 Leveling Legs with Locknuts

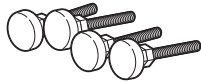

Tools Needed

Phillips-head Screwdriver



9/16" Open End Wrench or Adjustable Wrench



8-mm Socket Wrench

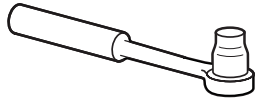

WARNING: Due to the size and weight of the washer or dryer, and to reduce the risk of personal injury or damage, 2 people are required for proper installation.

Note:

- DO NOT remove washer shipping bolts prior to pedestal installation. Shipping bolts MUST be reinstalled, if previously removed.
- Care should always be taken when laying the washer or dryer on its side to prevent component damage.
- Do not lay washer or dryer on its back. Use a pad or protective surface when laying washer or dryer on its side.

To install the pedestal:

1. Lay the washer or dryer on its side.
2. Remove the 4 leveling legs.

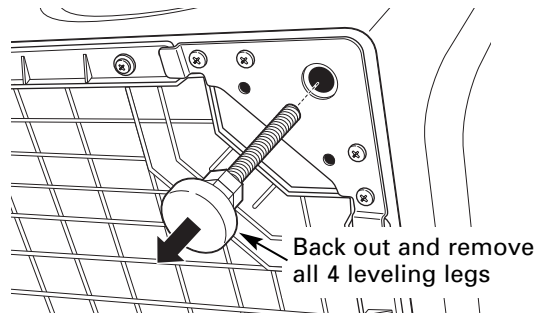

3. Pull the drawer out to its stop position.
4. Remove the screws from the drawer slides.
5. Slide the drawer out of the base and set it aside.

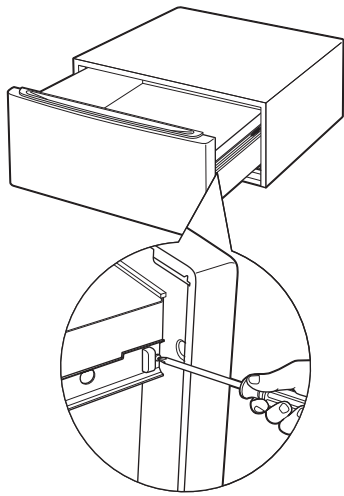

Note: The support pads should be installed on the dryer only. **DO NOT INSTALL THE PADS ON THE WASHER PEDESTAL.**

6. Install a support pad at each top corner of the pedestal. Ensure both protrusions on each pad are inserted in the holes on top of the pedestal.

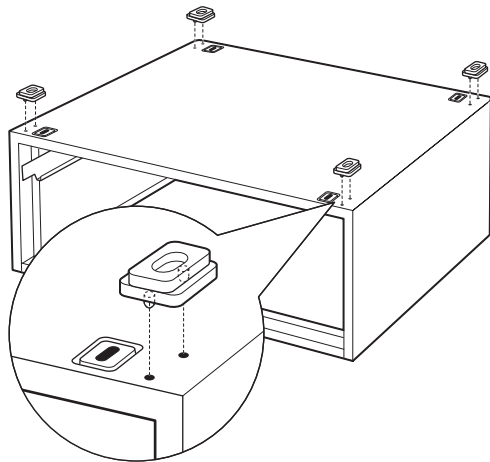

7. Place the pedestal against the bottom of the washer or dryer. Ensure that the drawer front is at the front of the washer or dryer.
8. Align the holes in the pedestal with the holes in the bottom of the washer or dryer base.
9. Use a Phillips-head screwdriver to install the 4 (8-mm) bolts through the pedestal and into the unit. **DO NOT** tighten the bolts.
10. Align the pedestal with the unit. Use an 8-mm socket wrench to securely tighten the bolts.

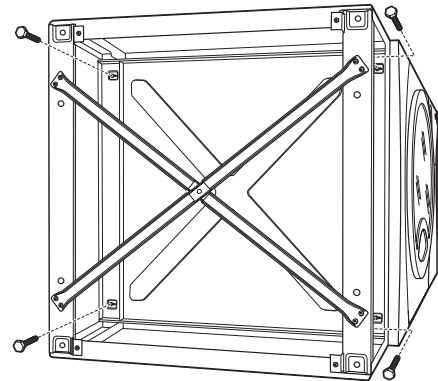

11. Screw locknuts onto the supplied leveling legs. Turn the nuts toward the bottom and against the rubber part of the leg.
12. Install the leveling legs, with locknuts, in each corner support. Screw the legs all the way into the pedestal. Do not tighten.

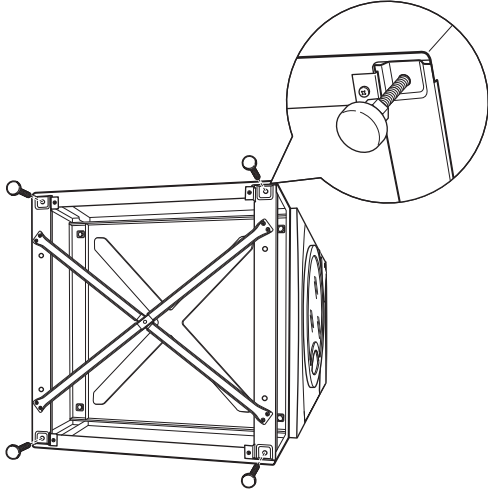

16. Ensure that the slides are closed, then slide the drawer into the opening.
17. Align the drawer supports to the slides on each side.
18. Reinstall the original screws in each drawer slide.

Note: The drawer should slide smoothly when you push it closed.

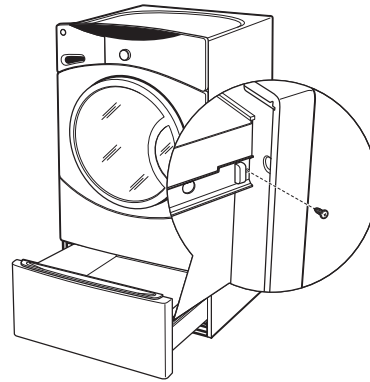

13. Stand the washer or dryer upright. Move it close to its final location.
14. Make sure that the washer or dryer is level by placing a spirit level on top. Check side to side and front to back.
15. Use an open end or adjustable wrench to adjust the legs in or out. Tighten the locknuts against the bottom of the pedestal.

19. Remove the 4 shipping screws from the back of the washer.

Note: Refer to the washer or dryer installation instructions to complete the installation.

Note: To minimize vibration, the locknuts must be tight.

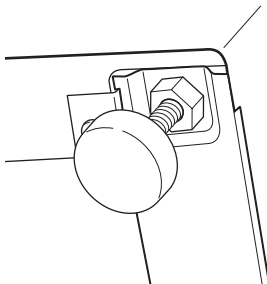

Stacking Instructions

The GE dryer is designed to allow placement (stacking) on top of certain GE front load washers. Washer models that currently qualify are:

- WBVH6240
- WCVH6260
- WHDVH626

The parts and instructions necessary to convert the separate units to a stack unit are included with the washer installation parts.

Note: The stacking parts and instructions are NOT included with the GE dryers but can be ordered separately. (Part # WE25X10018)

Note: Reverse the dryer door swing (if desired) BEFORE stacking. The washer door swing is NOT reversible.

WARNING!

- Make sure the dryer is unplugged.
- More than 2 people are recommended to safely lift the dryer into position.
- Avoid damage to the existing utility services.
- DO NOT place the washer on top of the dryer.
- Stacking of a gas dryer is NOT permitted in a mobile home or a manufactured home.

Location Requirements

When installed in a location other than an alcove or closet, the minimal clearances to combustible surfaces and for air opening are: 0 inches on both sides, and 1 inch at the rear.

Note: If your dryer is approved for installation in an alcove or a closet, it will be stated on a label on the back.

When installed in an alcove or closet:

- Minimum clearance between dryer cabinet and adjacent walls or other surfaces is 0 inches either side, and 3 inches front and rear.

- Minimum vertical space from floor to overhead cabinets, ceiling, etc. is 43 inches without pedestal, 55 inches with pedestal, and 84 inches stacked. Closet doors must be louvered or otherwise ventilated and must contain a minimum of 120 square inches of open area, equally distributed.
- The dryer MUST be vented to the outdoors. (Refer to dryer installation instructions for details.)

Kit Contents

Right Bracket

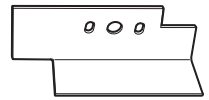

Left Bracket

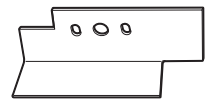

4 Rubber Pads



4 #12 x 1" Screws



4 #8 x 1/2" Screws



Tools Needed

Phillips Screwdriver

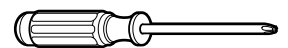

Open End Wrench



Pliers

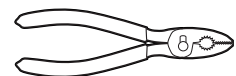

Gloves



Level



(Continued Next Page)

To stack the dryer:

Caution: Do not lay dryer on its back. Use the packing material or a protective surface when laying dryer on its side.

1. Carefully lay the dryer on its side.

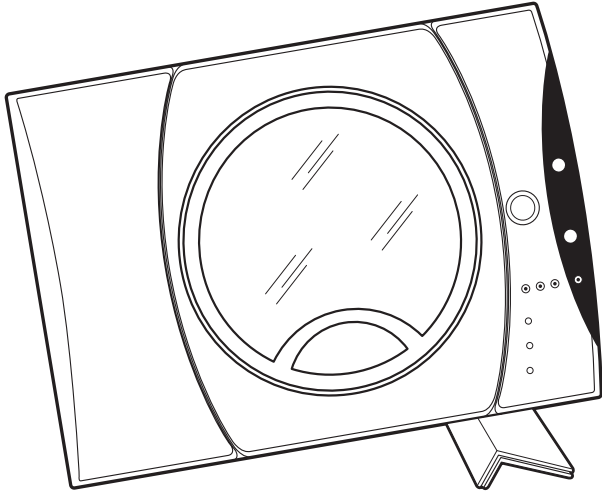

2. Use an open end wrench or pliers to remove the 4 dryer leveling legs from the leg brackets.

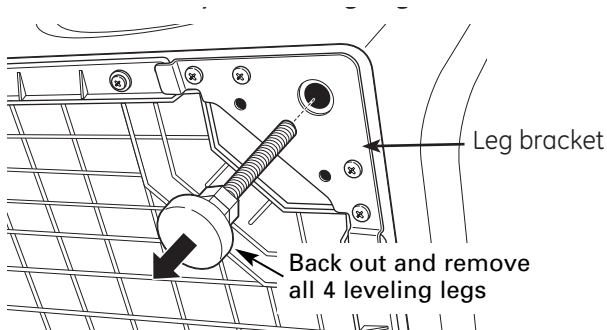

3. Remove the adhesive backing and firmly place the 4 rubber pads over the leg brackets.

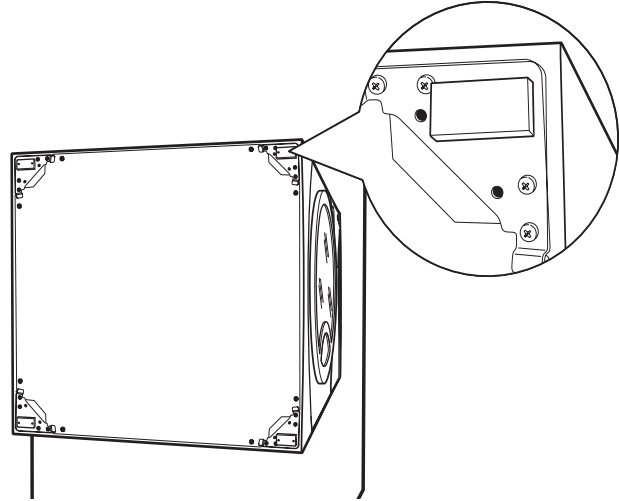

4. Align the holes in the left bracket with the holes in the bottom left corner of the dryer. Attach the bracket using 2 (#12 x 1-in.) Phillips-head screws.

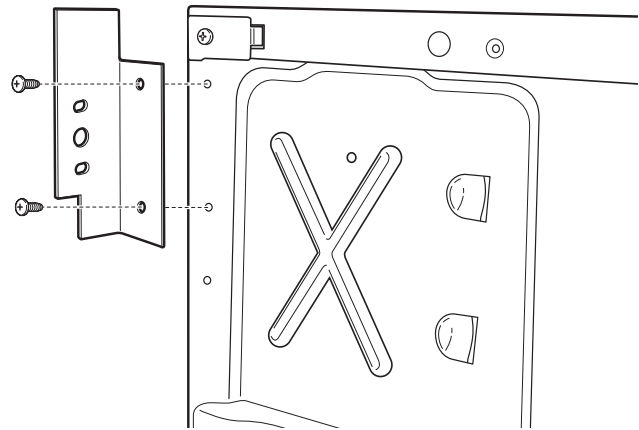

5. Align the holes in the right bracket with the holes in the bottom right corner of the dryer. Attach the bracket using 2 (#12 x 1-in.) Phillips-head screws.

6. Set the dryer upright using packing material or a protective surface that ensures the brackets do not damage the floor.
7. Place and level the washer in the approximate location. (Refer to washer installation instructions for details.)
8. Remove the 3 Phillips-head screws that attach the top cover, then pull the cover rearward.

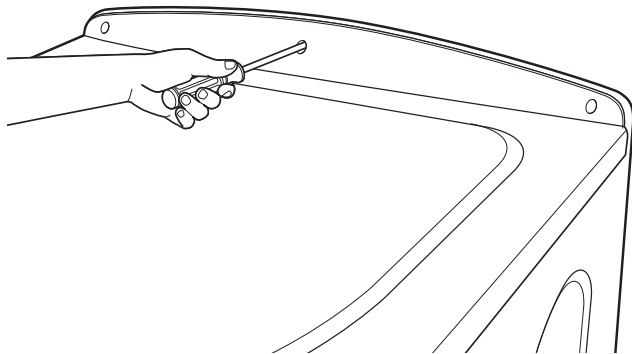

Caution: Protect the washer control panel with cardboard or other protection to prevent damage caused by contact with the dryer brackets.

9. Lift the dryer high enough to clear the washer control panel and place the dryer on top of the washer.
10. Align the holes in the brackets with the holes in the back of the washer. Attach the brackets to the washer using 4 (#8 x ½-in.) Phillips-head screws.

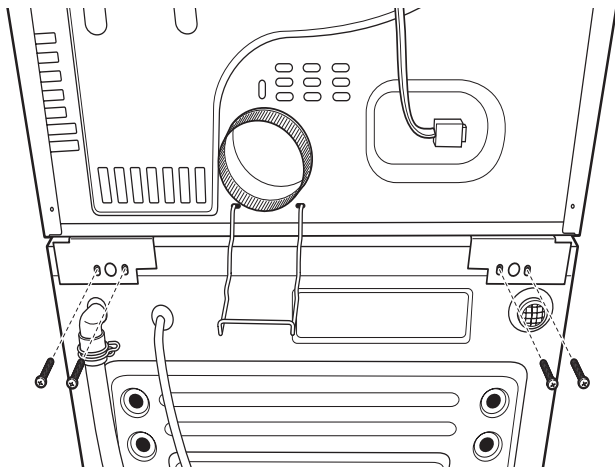

WARNING!

Do not push on the dryer after it is stacked on the washer. Pushing on the dryer may result in pinched fingers.

Caution: Use felt pads or other sliding device to assist moving and to protect flooring.

Note: Ensure that the washer and the dryer are in compliance with their respective installation instructions.

11. Carefully slide or walk the stacked washer and dryer into place.

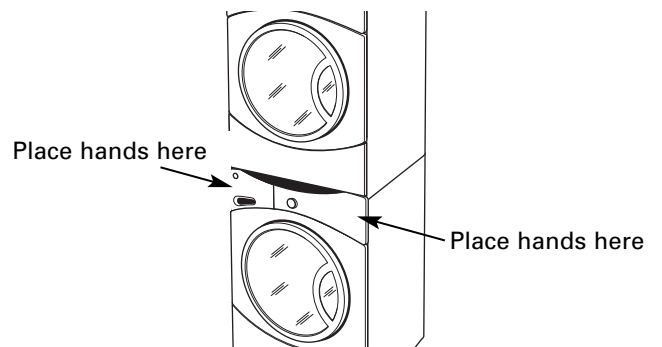

Operation Overview

Air enters the dryer cabinet, passing thru the heating elements and into the drum. The hot air heats the wet clothes, gradually removing their moisture in the form of water vapor. The moist air is vented through the dryer exhaust. Overall heater temperature is regulated by means of two temperature sensors, an inlet sensor, located near the heating elements, and an outlet sensor, located at the blower. An additional safety thermostat, located near the heating elements, shuts off the heating elements if they overheat. Also, the outlet backup thermostat, located near the blower, provides additional safety and cycles the heaters if temperature goes above the outlet temperature range.

Dryer Air Flow System

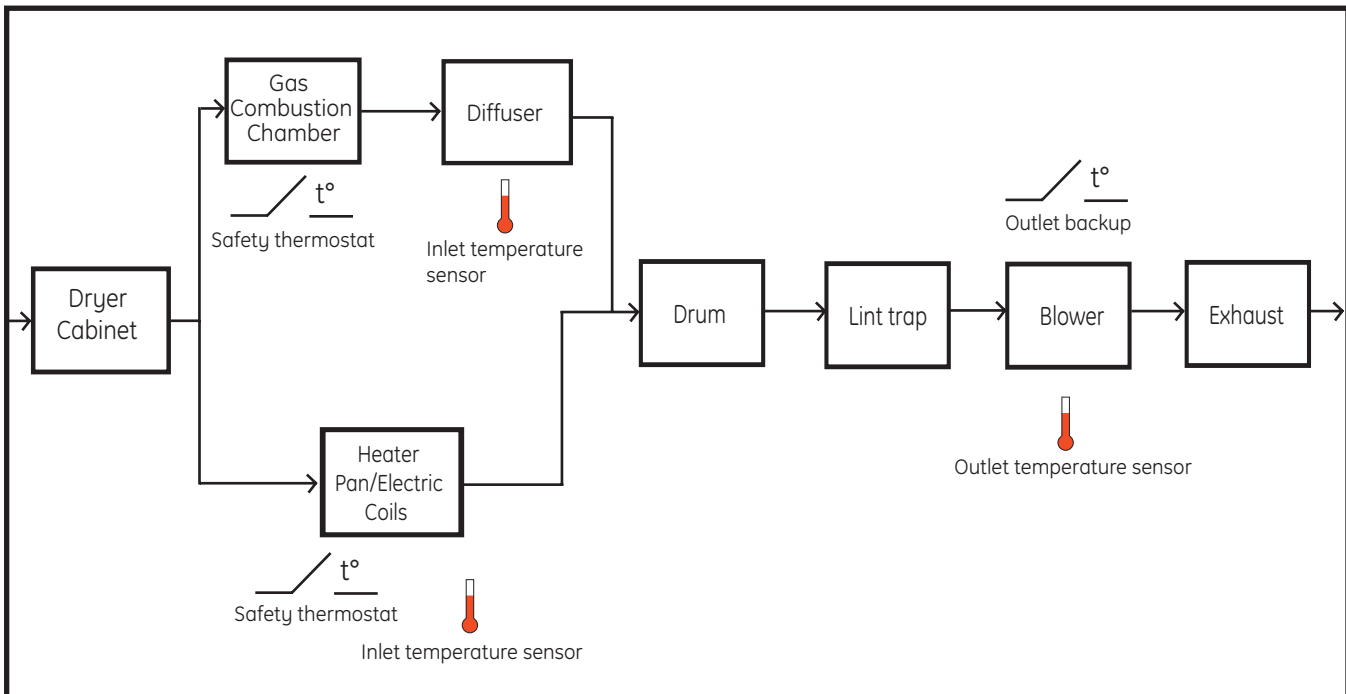

The typical dryer cycle progresses as follows:

1. A cycle is selected and the start key is pressed.
2. The motor is activated.
3. The heater coils (burner for gas models) are activated. The coils (burner) cycle on and off to achieve the desired temperature throughout the heating portion of the cycle.
4. If sensor drying is selected, the heater coils (burner for gas models) are activated. The coils (burner) cycle on and off until the load has achieved the desired dryness level.
5. If timed drying is selected, the heater coils (burner for gas models) are activated and cycle on and off for the selected time at the selected temperature.
6. The heater coils (burner for gas models) discontinue operation after the dryness level or elapsed time has been achieved.
7. The motor continues operating until the clothes temperature drops below specified temperature (Cool Down).
9. The display turns off.

Airflow

Gas Dryer

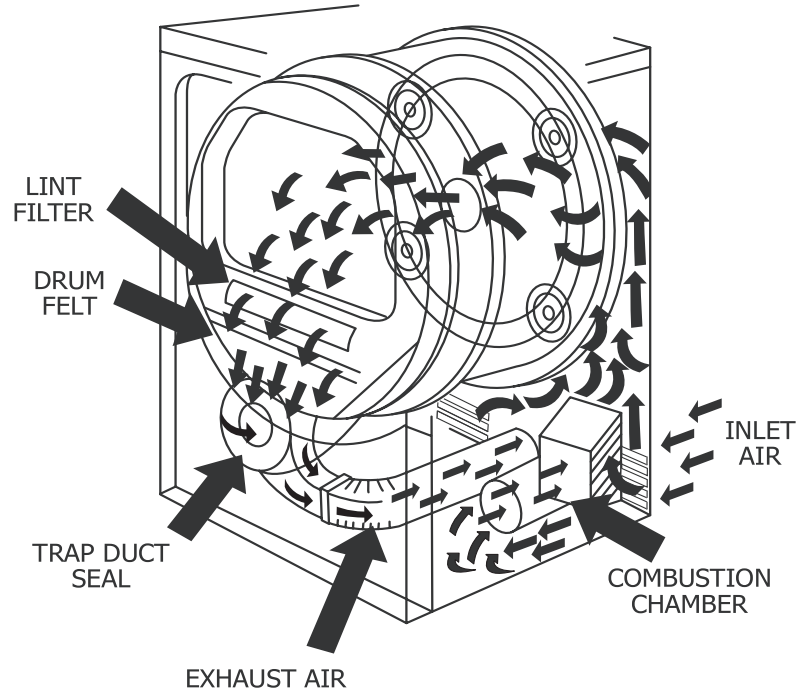

Electric Dryer

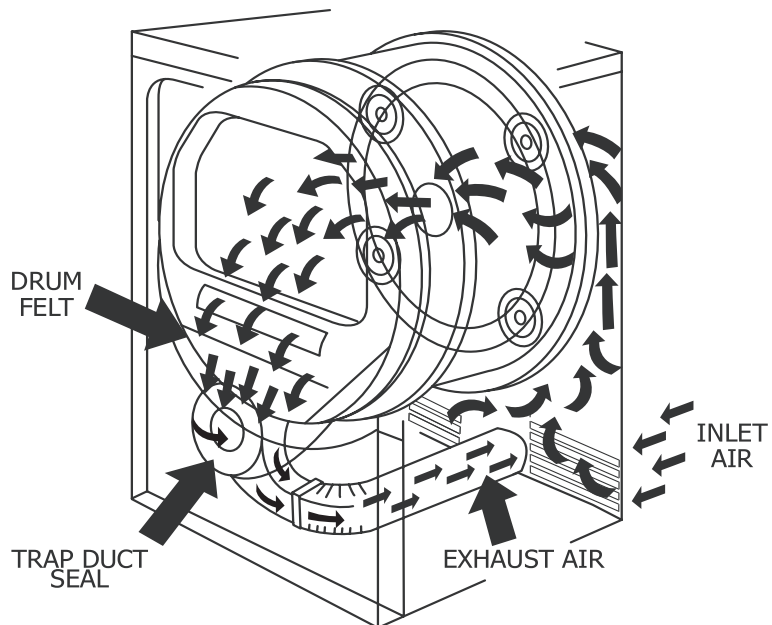

Component Locator Views

Electric Model

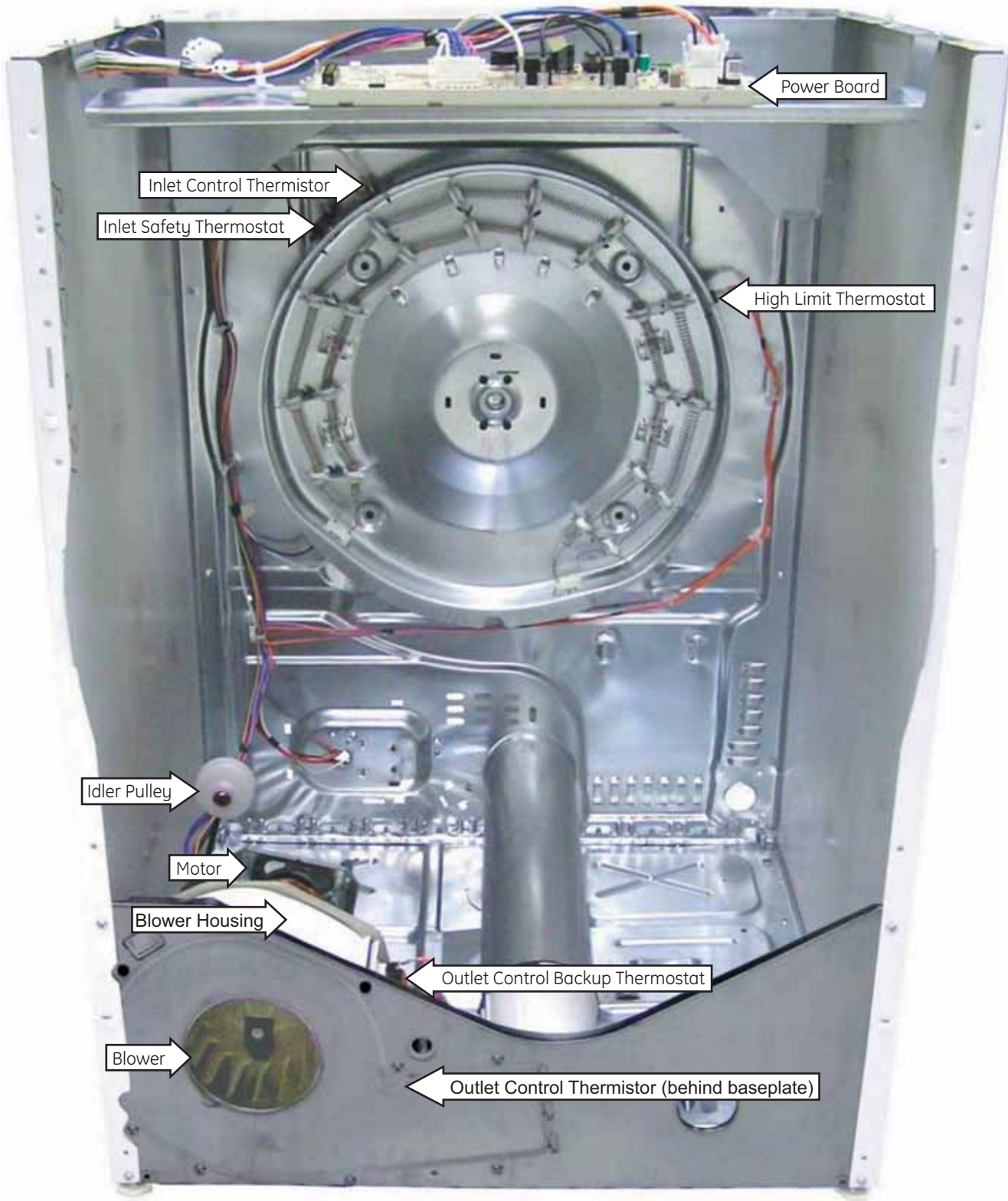

Gas Model

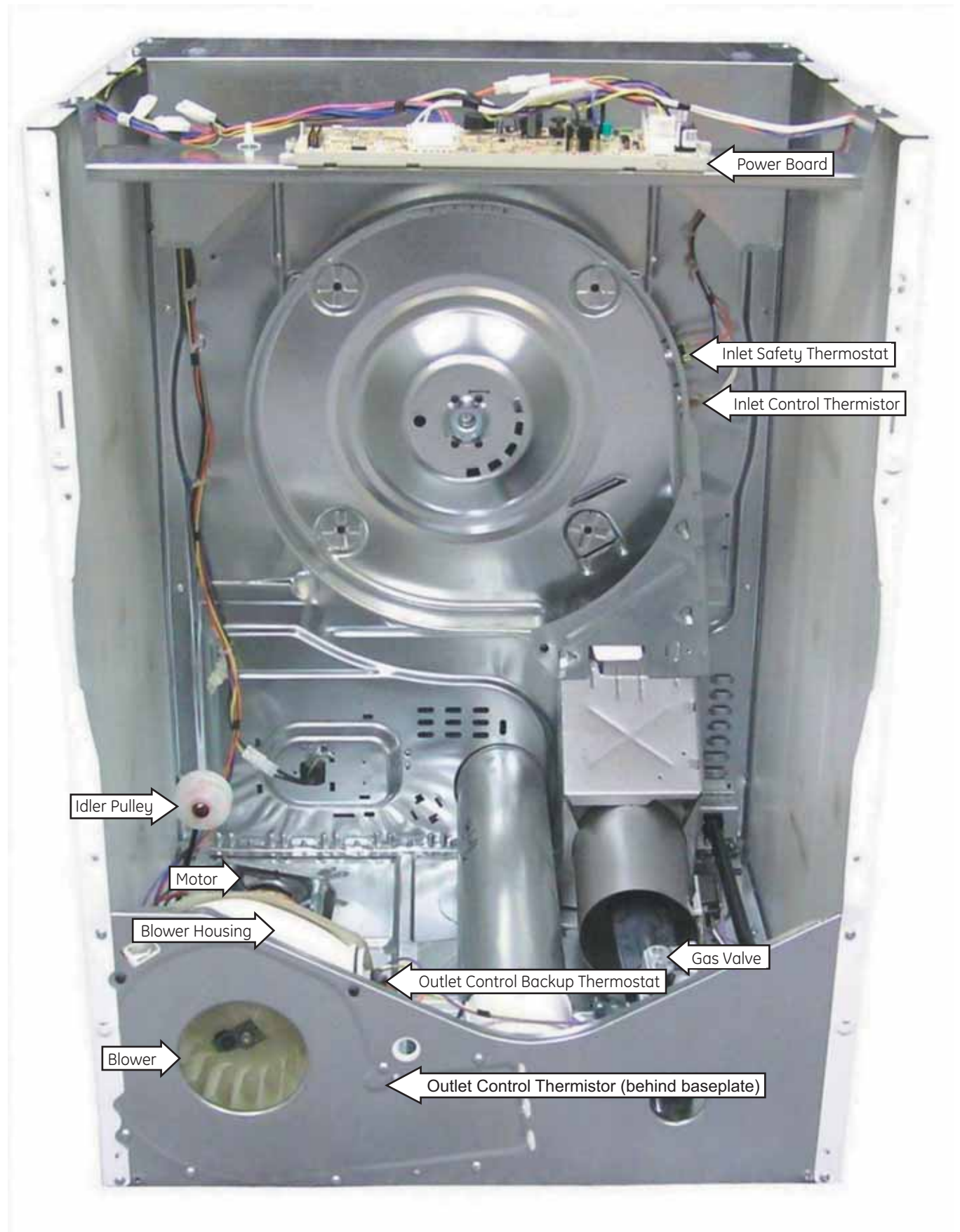

Power Board-Electric Models

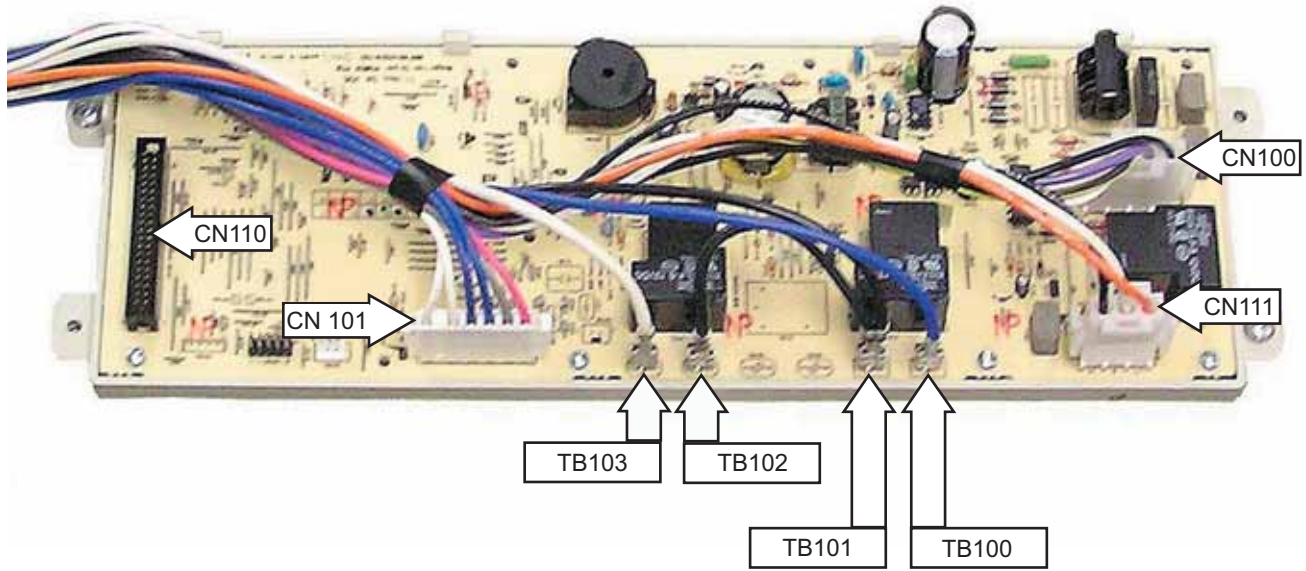

Power Board-Gas Models

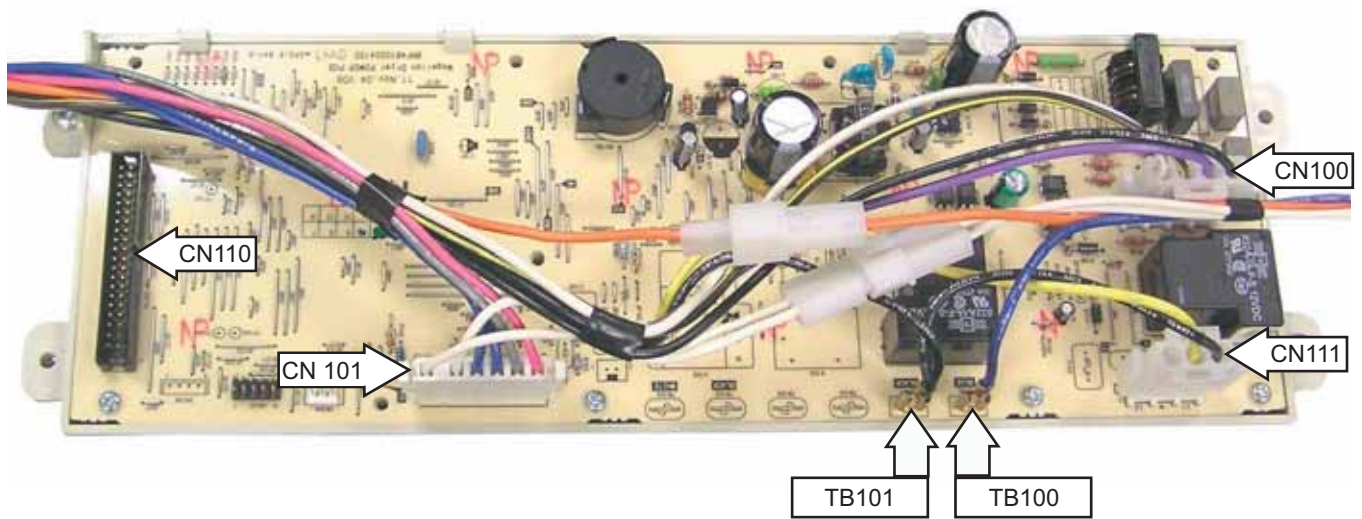

Control Board Assembly (Electric and Gas Models)

Rear View

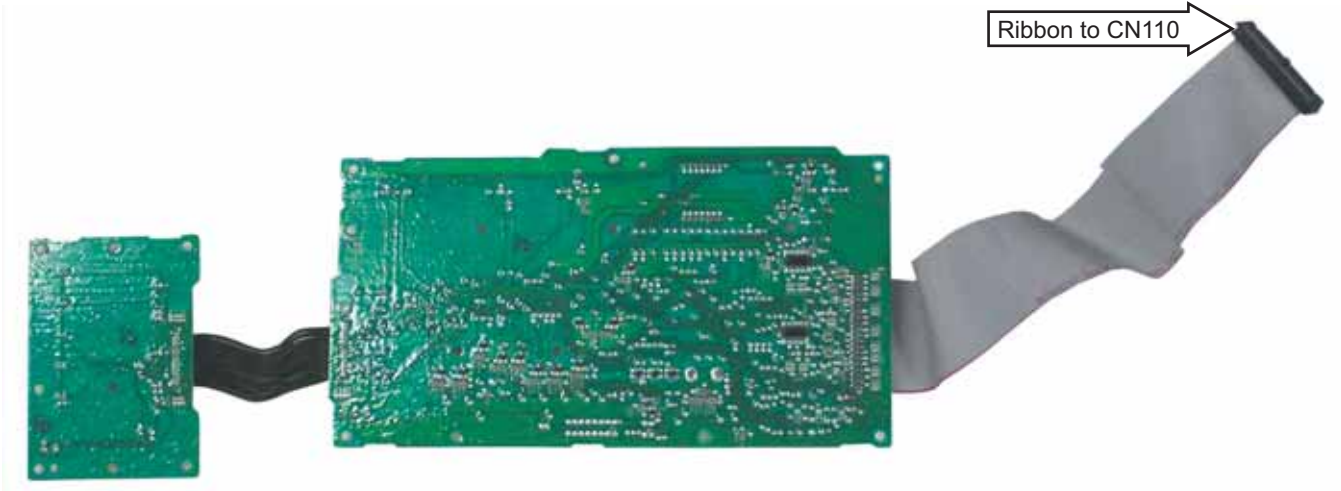

Front View



Dryer Components

Top Panel

WARNING: Sharp edges may be exposed when servicing the dryer. Use caution to avoid injury. Wear Kevlar gloves or equivalent protection.

Note: Combined Phillips-head/square-drive recess screws are utilized throughout this appliance. Either Phillips or square-drive screwdrivers can be used to extract or install these screws.

Removal of the top panel provides access to the power board. The top panel is held in place with 2 Phillips-head screws (located under the control panel cover) and 2 rear tabs.

To remove the top panel:

1. Remove the 3 Phillips-head screws that attach the control panel cover. Pull the cover rearward.

Note: It may be helpful to place a putty knife along the top seam between the cover and the control panel, then tap lightly rearward.



2. Remove the 2 Phillips-head screws that attach the top panel to the cabinet.
3. Raise the front of the top panel approximately 3 inches, then pull forward to clear the rear tabs.



Control Panel

Removal of the control panel provides access to the control board assembly. The control panel is held in place with 2 screws on the top and 4 bottom tabs.

To remove the control panel:

1. Remove the top panel. (See **Top Panel**.)
2. Disconnect the control board ribbon from the power board at connection CN110.
3. Remove the 2 Phillips-head screws that attach the top of the control panel to the cabinet.

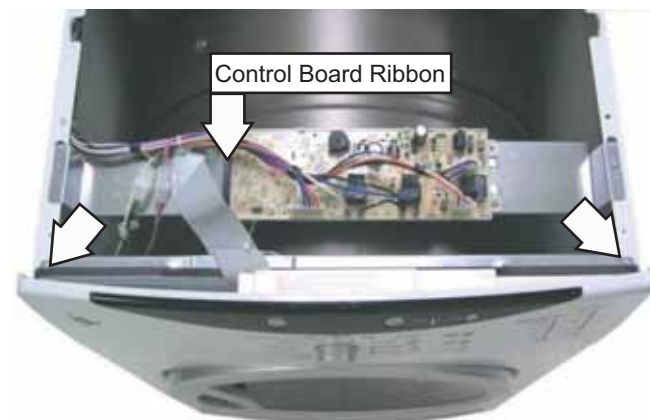

4. Raise the control panel vertically.

Front Panel

Removal of the front panel provides access to the drum and drive belt. The front panel is held in place by 4 screws.

To remove the front panel:

1. Remove the top panel. (See **Top Panel**.)
2. Remove the control panel. (See **Control Panel**.)
3. Disconnect the door switch wire harness and the sensor rod wire harness to the power board.



Note: In the following step it may be necessary to raise the front of the dryer to gain access to the screws.

4. Remove the 4 Phillips-head screws that hold the front panel to the cabinet.



Drive Belt

WARNING: Sharp edges may be exposed when servicing the dryer. Use caution to avoid injury and wear Kevlar gloves or equivalent protection.

The drive belt (part # WE12M22) extends from the motor pulley, past the idler pulley, and around the perimeter of the dryer drum. Belt tension is maintained by the idler pulley and driven by a pulley attached to the rear of the motor shaft.

To remove the drive belt:

1. Remove the top, control, and front panels. (See **Top Panel**, **Control Panel** and **Front Panel**.)

WARNING: The idler arm is under high tension. To prevent injury, do not let the idler arm snap back.

2. Reach under the left side of the drum, push the idler pulley down and to the right, then lock the idler arm on the top corner of the motor support.

Locked Position

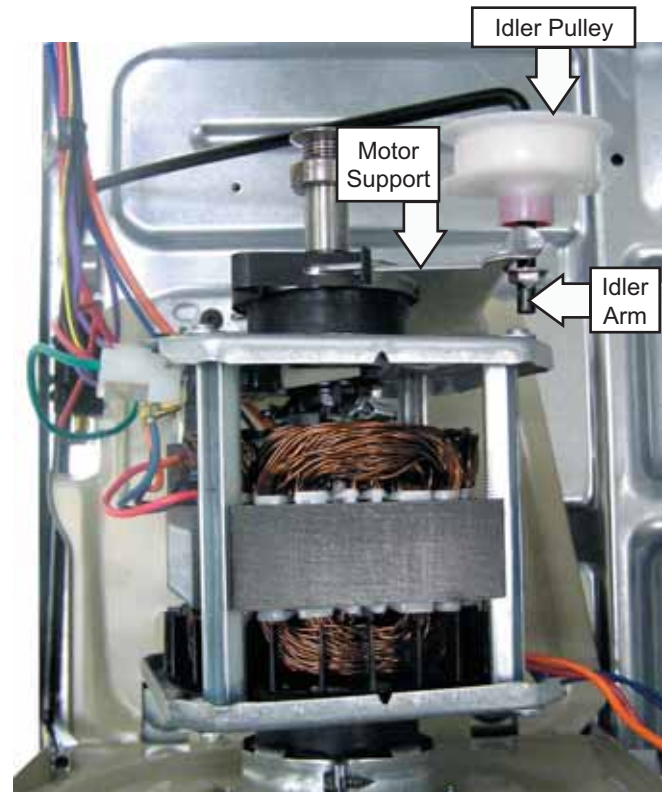

3. Remove the belt from the motor pulley and idler pulley. Guide the belt past the front of the cabinet base.

Drum

The drum is made of 304 stainless steel and has three replaceable baffles. The drum rotates counterclockwise, as viewed from the front, at a speed of 47 to 51 RPM.

To remove the drum:

1. Remove the top, control, and front panels. (See **Top Panel**, **Control Panel** and **Front Panel**.)
2. On gas models, disconnect the inlet control thermistor and the inlet safety thermostat wire harnesses.

Gas Model



3. Disengage the front plastic wire retainer from the cabinet by pressing the tabs inward.
4. Remove the 2 Phillips-head screws that attach the power board bracket to the cabinet. Carefully place the bracket on the rear plate.

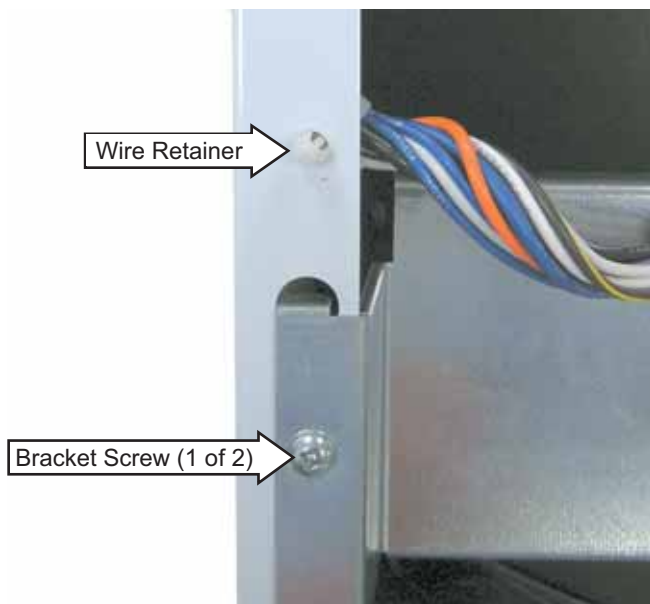

5. Remove 1 Phillips-head screw from each side of the cabinet, then gently spread the sides apart to provide clearance for the drum.



6. Remove the drive belt from the motor and idler pulley. (See **Drive Belt**.)
7. Using the belt as a handle, pull the drum forward and guide it out of the cabinet.



Drum Shaft Bearing

The drum shaft bearing is mounted on the drum shaft at the rear of the drum. The bearing fits into the bearing retainer in the center of the heater assembly.

To remove the drum shaft, remove the drum (See **Drum**.) then remove the 3 Torx screws (T-20) that attach the drum shaft to the rear of the drum.

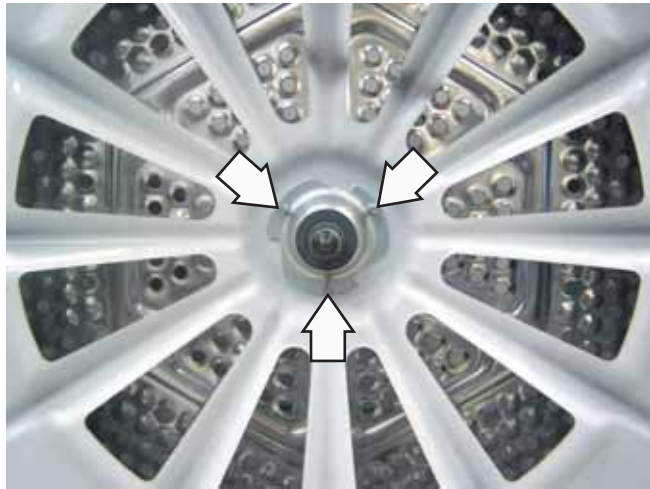

Idler Assembly

The idler assembly maintains proper tension on the belt to minimize belt slippage. The idler assembly consists of an idler pulley that rotates on an idler arm. The pulley is retained on the arm using a cap nut. The idler arm is positioned on the chassis and inserted in a slot in the motor base plate. The assembly is located to the left of the motor.

WARNING: Sharp edges may be exposed when servicing the dryer. Use caution to avoid injury. Wear Kevlar gloves or equivalent protection.

To remove the idler assembly:

1. Remove the drive belt. (See **Drive Belt**.)

WARNING: The idler arm is under high tension. To prevent injury, do not let the idler arm snap back.

2. Release tension on the idler assembly by unlocking the idler arm from the top right corner of the motor support.
3. Remove the idler arm from the slot in the motor base plate.



4. Remove the idler assembly from the dryer.

Motor and Blower Wheel Assembly

The motor is a single speed, 120 VAC, ¼-hp, 5.2 amp rated motor with an automatic reset overload protector. The overload protector is an internal component of the motor and cannot be replaced separately. The motor contains a centrifugal switch that serves three purposes:

- Disengages the motor start winding (M6).
- Engages the motor run winding (M5).
- Closes the circuit contacts for the heat source.

The switch is an internal component of the motor and cannot be replaced separately.

The blower wheel is held to the motor shaft utilizing a blower wheel clamp.

Motor resistance values:

Start winding = approximately 5 Ω

Run winding = approximately 4 Ω

Note: The motor and blower wheel assembly must be removed to replace the motor or blower wheel separately.

To remove the motor and blower wheel assembly:

1. Remove the top, control, and front panels. (See **Top Panel**, **Control Panel** and **Front Panel**.)
2. Remove the drum. (See **Drum**.)
3. Remove the idler assembly. (See **Idler Assembly**.)

4. Disconnect the 2 blue wires from the outlet control thermistor.
5. Remove the single Phillips-head screw that attaches the outlet control backup thermostat to the blower housing.
6. Disconnect the purple and the brown wires from the belt switch.
7. Disconnect the motor wire harness.

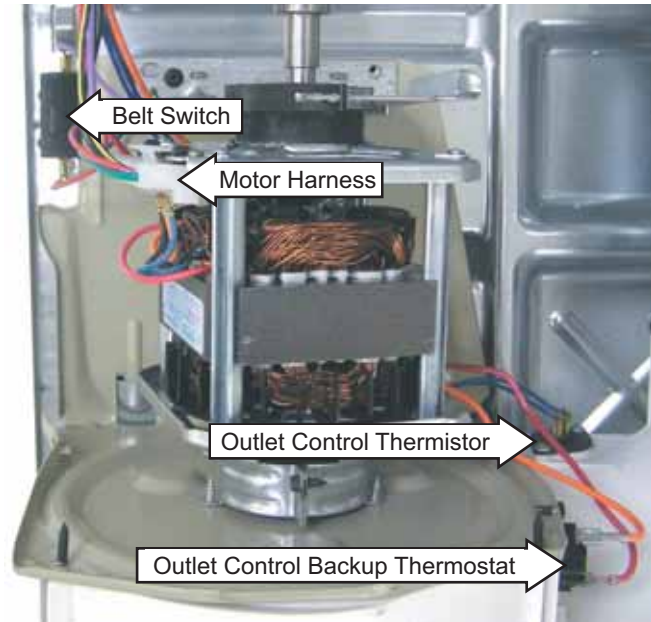

8. Remove the ¼-in hex-head screw that attaches the ground wire to the motor support.
9. Remove the single vertical and single horizontal Phillips-head screws that attach the motor support to the base plate.



10. Remove the 2 Phillips-head screws that hold the top of the motor base plate to the blower housing.



11. Raise the rear of the motor bracket to clear the tab protruding from the bottom of the base plate. Pull rearward and remove the motor and blower wheel assembly from the base plate.

Note: When installing the motor and blower wheel assembly, ensure that the 2 front tabs and the 2 rear tabs on the motor bracket are inserted into slots provided in the bottom of the base plate.

To replace the blower wheel:

Loosen the $\frac{3}{8}$ -in. hex-head screw that secures the blower wheel clamp to the motor shaft. Pull the blower wheel off the shaft.



To replace the motor:

1. Remove the 2 Phillips-head screws that hold the front motor strap to the motor base plate.



- Remove the 2 hex-head screws that hold the front motor strap to the motor.
- Compress then remove the rear motor strap from the motor base plate.

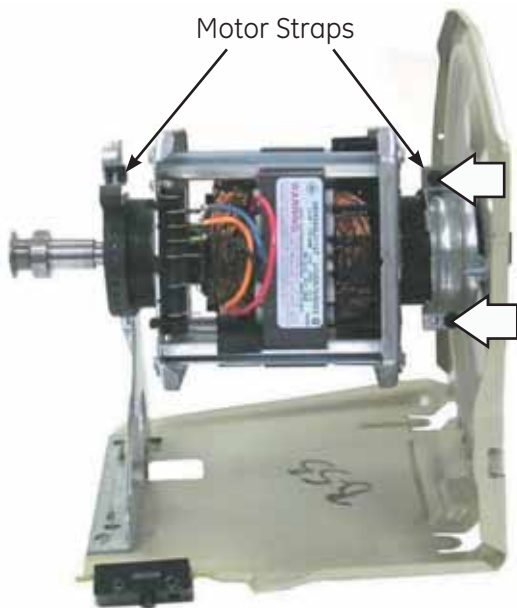

Belt Switch

The belt switch is fastened to the motor baseplate with 2 Phillips-head screws. The belt switch is activated by the movement of the idler arm. If the drive belt breaks or comes off the idler pulley, the belt switch opens power to the motor interrupting dryer operation. The drum lamp will operate with an open belt switch.

To remove the belt switch:

- Remove the top, control, and front panels. (See *Top Panel, Control Panel* and *Front Panel*.)
- Remove the drum. (See *Drum*.)
- Remove the motor and blower wheel assembly. (See *Motor and Blower wheel Assembly*.)
- Remove the 2 Phillips-head screws that attach the belt switch to the motor baseplate.

Blower Housing

The blower housing is attached to the dryer with 7 screws and 3 tabs.

To remove the blower housing:

- Remove the top, control, and front panels. (See *Top Panel, Control Panel* and *Front Panel*.)
- Remove the drum. (See *Drum*.)
- Remove the idler assembly. (See *Idler Assembly*.)
- Remove the motor and blower wheel assembly. (See *Motor and Blower wheel Assembly*.)
- Remove the single Phillips-head screw located inside the outlet of the exhaust pipe. Remove the exhaust pipe from the blower housing.

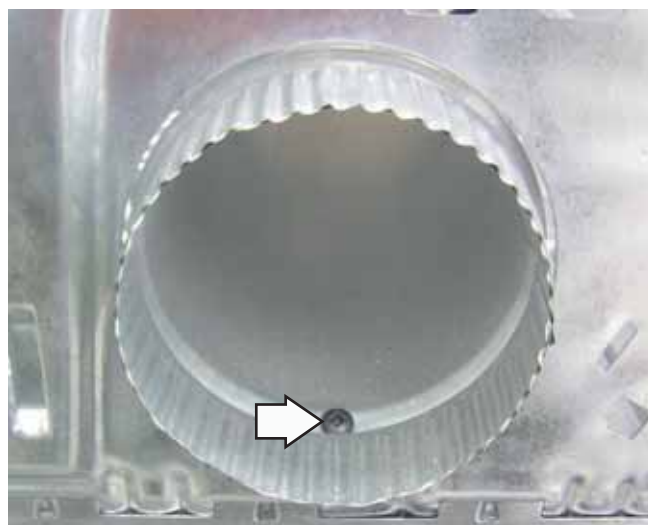

- Remove the 7 Phillips-head screws that attach the blower housing to the base plate.
- Slide the blower housing to the right.

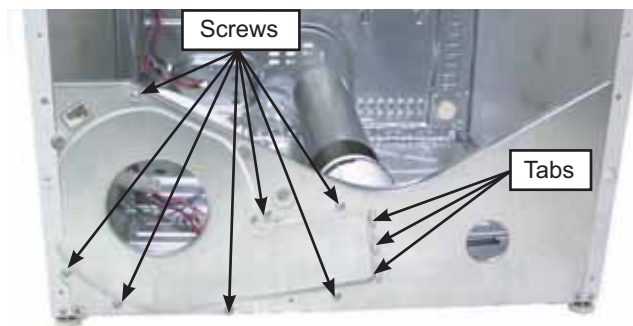

Note: When reinstalling the blower housing, ensure the 3 tabs are inserted into the front base plate.

Heater Assembly

The heater assembly is located behind the drum. It consists of 2 open coils fastened to a single housing. The inner coil and the outer coil are each individually controlled by separate relays on the power board. When energized, each coil draws 12.5 amps at 240 VAC. Each coil has an approximate resistance value of 19.2 Ω .

To remove the heater assembly:

WARNING: Sharp edges may be exposed when servicing the dryer. Use caution to avoid injury. Wear Kevlar gloves or equivalent protection.

1. Remove the top, control, and front panels. (See **Top Panel**, **Control Panel** and **Front Panel**.)
2. Remove the drum. (See **Drum**.)
3. Disconnect the lead wires from the heaters, inlet safety thermostat, inlet control thermistor, and the high limit thermostat,
4. Remove the 4 Phillips-head screws that attach the heater housing to the cabinet.

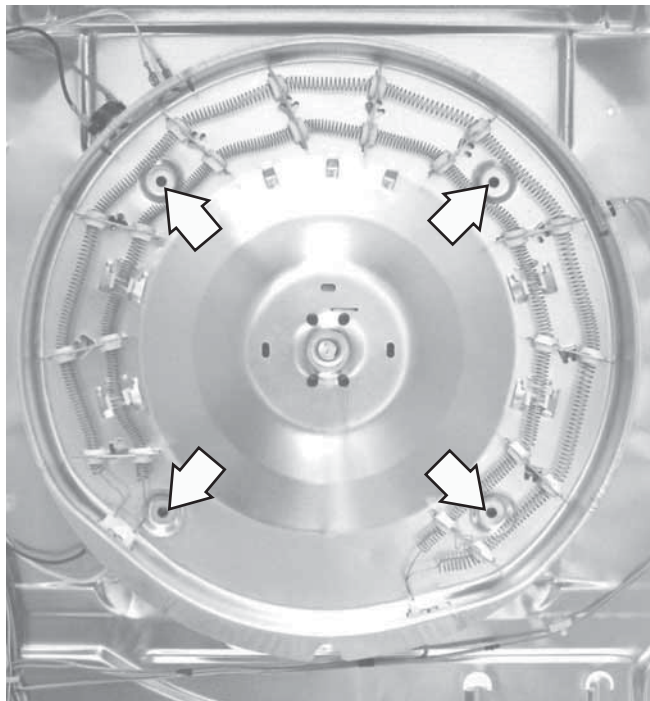

Gas Valve

The gas valve is attached to a bracket located in the bottom, right, front corner of the dryer cabinet.

To remove the gas valve:

1. Shut the gas off to the unit.
2. Remove the top, control, and front panels. (See **Top Panel**, **Control Panel** and **Front Panel**.)
3. Remove the drum. (See **Drum**.)
4. Disconnect the coil wire harness from each coil.
5. Disconnect the ignitor wire harness.
6. Disconnect the elbow coupling from the gas valve by turning counterclockwise (toward the rear of the dryer).
7. Remove the 2 Phillips-head screws that attach the gas valve bracket to the chassis bottom and pull bracket toward the front of the dryer and remove.

Coil Wire Harnesses

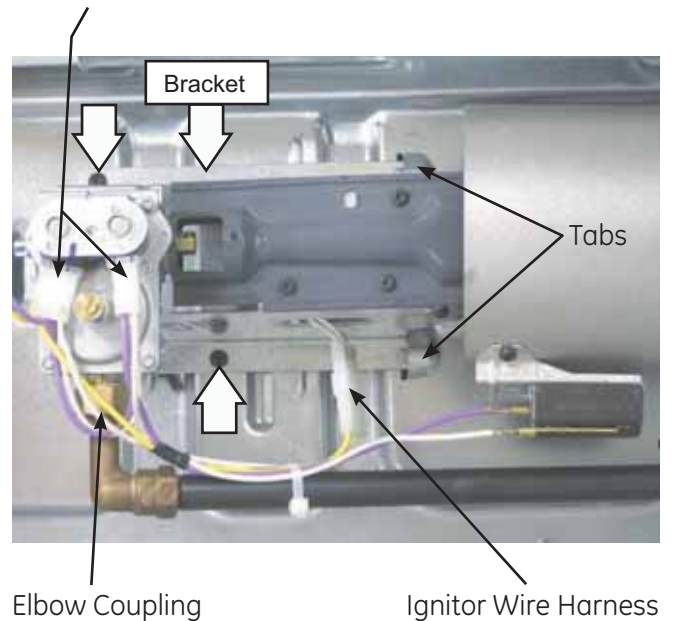

8. Remove the coils from the gas valve. (See **Coils**.)
9. Turn the bracket over. Remove the 2 Phillips-head screws that attach the gas valve to the gas valve bracket.

Note: Upon reassembly, ensure the gas valve bracket is inserted under the 2 tabs located in the chassis bottom.

Gas Valve Coil Assembly

The gas valve coil assembly is located on top of the gas valve in front of the combustion chamber opening. The assembly consists of a double coil (saftey and booster coils combined) and a single main coil. The coil assemblies can be replaced separately.

Gas valve coil assembly resistance values:

- Saftey coil terminals - 1350 Ω
- Booster coil terminals - 550 Ω
- Main coil terminals - 1300 Ω

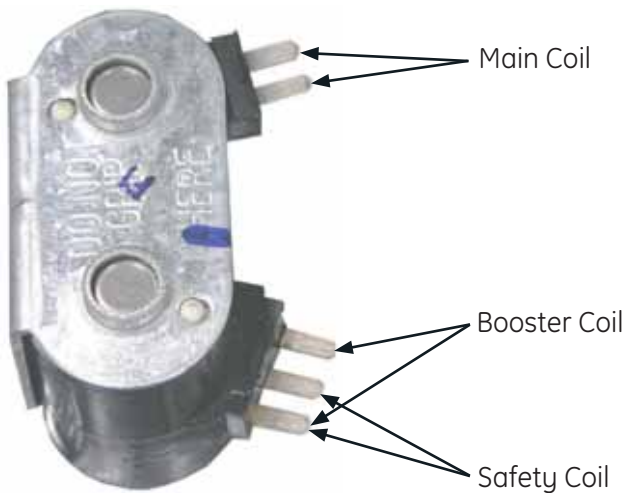

To remove the coils:

1. Remove the top, control, and front panels. (See **Top Panel**, **Control Panel** and **Front Panel**.)
2. Remove the drum. (See **Drum**.)
3. Disconnect the wire harness from both coils.

4. Remove the 2 Phillips-head screws that attach the coil bracket to the valve body.

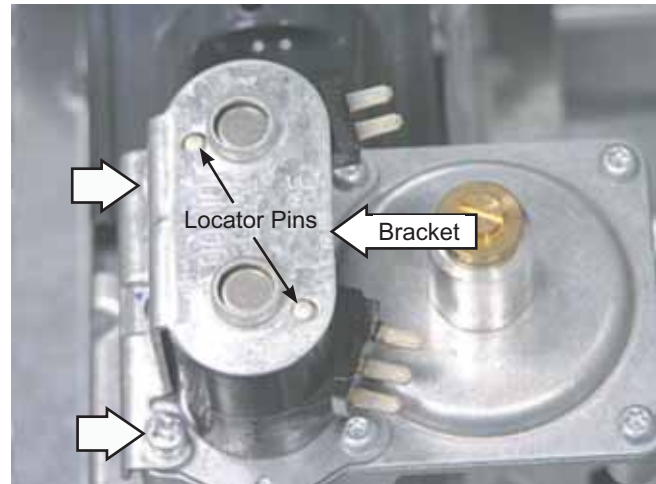

5. Lift the bracket vertically. Lift coils to remove.

Note: Upon reassembly, ensure the locator pins are inserted into the holes provided in the coil bracket.

LP Conversion

The gas dryer comes equipped for natural gas. The dryer can be converted to LP gas by using the conversion kit WE25X217. Should you need to convert an LP dryer back to natural gas and the original parts are missing, a WE25X218 kit contains all the parts required to convert back to natural gas.

Ignitor

The ignitor is located at the end of the gas valve assembly in the combustion chamber opening and has a maximum rating of 4 amps. The ignitor has an approximate resistance value of 300 to 500 Ω .

WARNING: Sharp edges may be exposed when servicing the dryer. Use caution to avoid injury. Wear Kevlar gloves or equivalent protection.

To remove the ignitor:

1. Remove the top, control, and front panels. (See *Top Panel, Control Panel* and *Front Panel*.)
2. Remove the drum. (See *Drum*.)
3. Disconnect the ignitor wire harness.
4. Remove the 3 Phillips-head screws that attach the burner to the bracket.

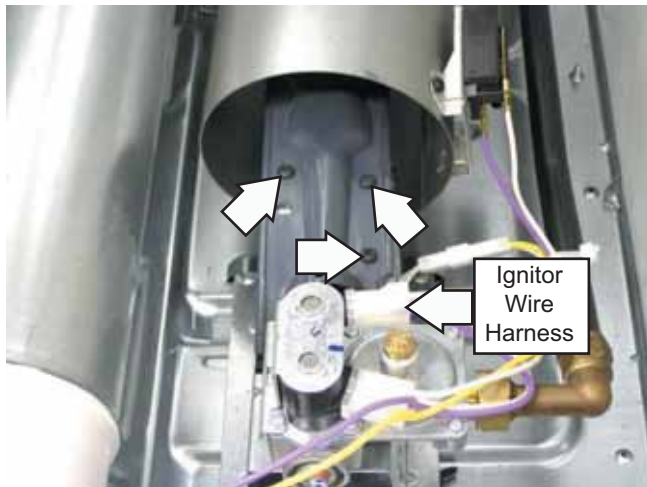

5. Remove the burner.
6. Remove the Phillips-head screw that attaches the ignitor to the bracket.

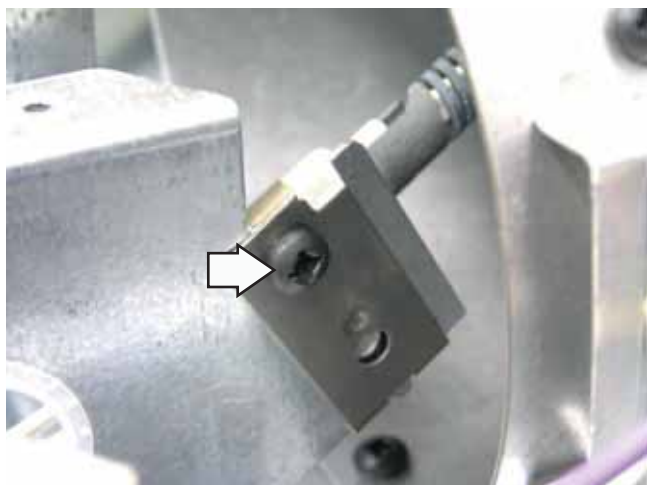

7. Rotate the base of the ignitor clockwise. Remove the ignitor.

Note: The ignitor is very fragile. Care must be taken to avoid breaking the ignitor when reinstalling the burner.

Flame Detector

The flame detector is attached to the right side of the combustion chamber.

To remove the flame detector:

1. Remove the top, control, and front panels. (See *Top Panel, Control Panel* and *Front Panel*.)
2. Remove the drum. (See *Drum*.)
3. Disconnect the 2 wires from the flame detector.
4. Remove the single Phillips-head screw that holds the flame detector to the combustion chamber.

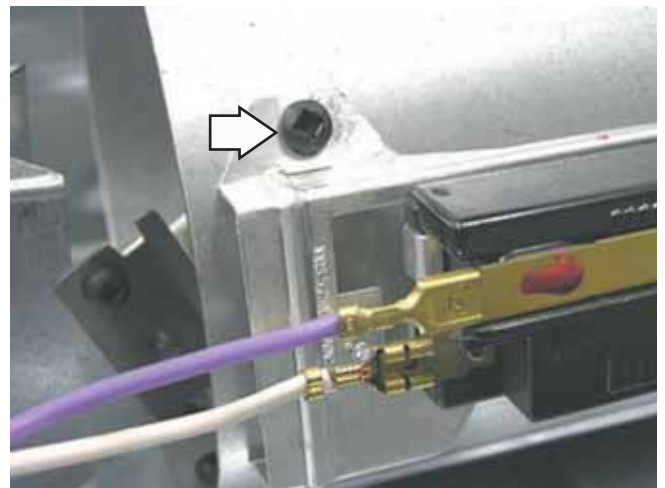

5. Remove the flame detector from the tab at the bottom.

Note: Upon reassembly, ensure the tab at the bottom of the flame detector is inserted into the slot located on the combustion chamber.

Ignitor Circuit Operation

The glo-bar ignitor circuit is made up of the following components: a gas valve with safety and main valves, ignitor, and a flame detector. The safety valve is actuated by a double coil that comprises a safety coil (resistance approximately 1350 ohms) and a booster coil (resistance approximately 550 ohms). Both coils are needed to open the safety valve. Once energized, the safety coil alone will hold the valve open. The main valve has a single coil (resistance approximately 1300 ohms).

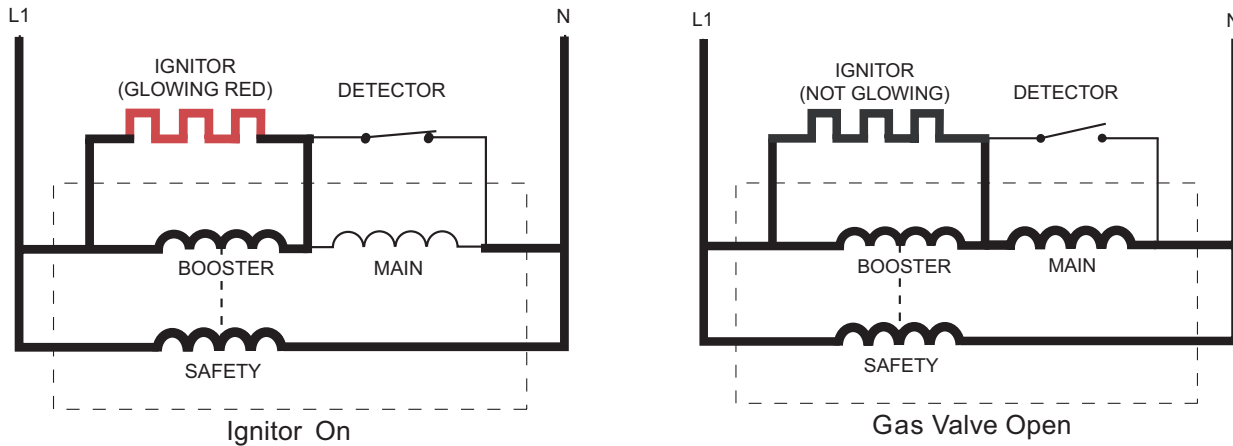

The flame detector (< 1 ohm) is mounted on the combustion chamber. It is normally in the closed position (N.C.). The flame detector is opened by the radiant heat produced by the glo-bar and once open, the flame detector will be held open by the radiant heat produced by the gas flame.

When the control system calls for heat, the following circuits are energized:

1. N- through detector, ignitor, outlet control backup, inlet safety thermostats to L1
2. N- through detector, booster coil, outlet control backup, inlet safety thermostats to L1
3. N- through safety coil and outlet control backup, inlet safety thermostats to L1

When the glo-bar is heating, the booster and safety coils are both energized and will open the safety valve. The main valve is closed as its coil is bypassed by the N.C. flame detector. When the glo-bar reaches ignition temperature, in approximately 60 seconds or less, the flame detector is heated and opens, which places the main coil in series with the glo-bar. The main valve opens, allowing gas to flow into the combustion chamber and ignite. The main coil, now in series with the glo-bar, causes the glo-bar to cool down. However, the flame detector is held open by the radiant heat from the gas flame. The booster coil is now also in series with the main coil and is essentially inoperative. Should a momentary power failure occur, the gas valve will shut off and an attempt to restart will not occur until the flame detector cools and resets, in approximately 30 seconds.

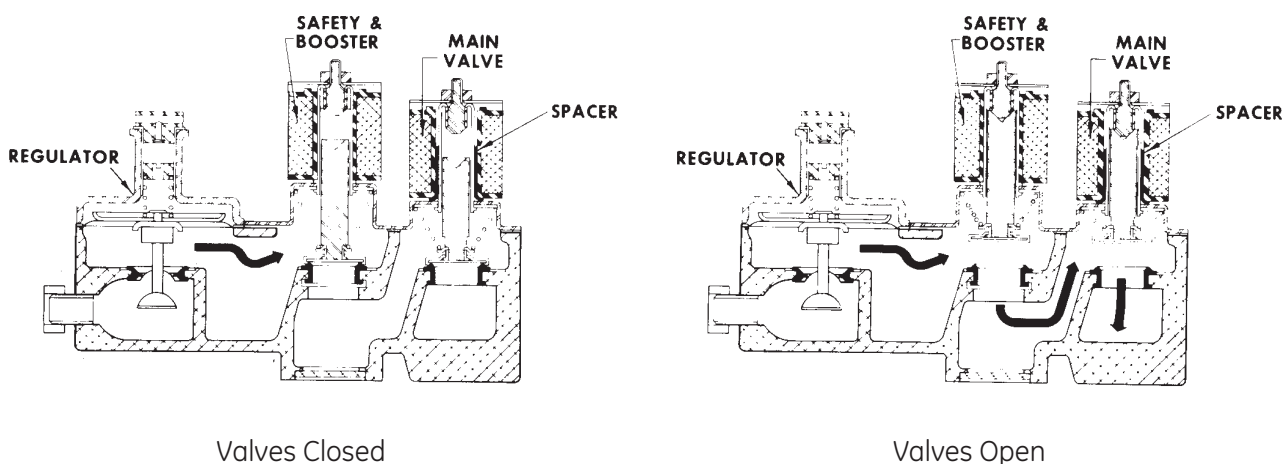

Inlet Safety Thermostat

The inlet safety thermostat is located on the top left area of the heater housing. It is left of the inlet control thermistor. The thermostat monitors incoming air temperature.

If the thermostat reaches a temperature beyond its maximum temperature rating, it will trip and disable power to the heating elements.

On electric dryers, the inlet safety thermostat opens at 210°F (99°C) and will automatically reset at 180°F (82°C). On gas dryers, the inlet safety thermostat opens at 300°F (149°C) and will automatically reset at 260°F (127°C).

To remove the inlet safety thermostat:

1. Remove the top, control, and front panels. (See **Top Panel**, **Control Panel** and **Front Panel**.)
2. Remove the drum. (See **Drum**.)
3. Disconnect the black and orange wires from the inlet safety thermostat.
4. Remove the single Phillips-head screw then lift and slide the thermostat from the heater assembly.

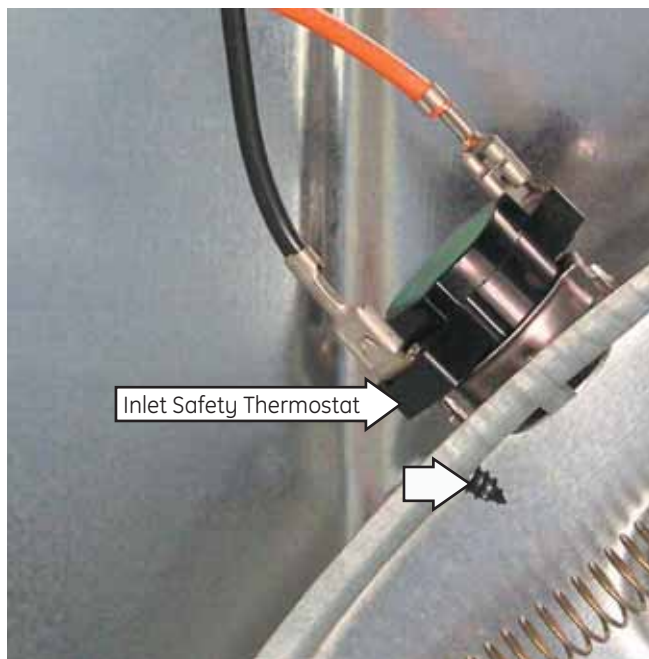

Inlet Control Thermistor

The inlet control thermistor is located on the top left area of the heater housing. It is right of the inlet safety thermostat. The thermistor monitors incoming air temperature and relays the information to the power board.

Inlet control thermistor resistance values:

- 80 Ω at 86°F (30°C)
- 100 Ω at 77°F (25°C)
- 120 Ω at 69°F (20.5°C)

Operation of the inlet control thermistor can be checked by using service test mode t08. (See **Service Test Mode**.)

Specific failures associated with the outlet control thermistor can initiate error codes E02 and E04. (See **Service Test Mode**.)

To remove the inlet control thermistor:

1. Remove the top, control, and front panels. (See **Top Panel**, **Control Panel** and **Front Panel**.)
2. Remove the drum. (See **Drum**.)
3. Disconnect the 2 white wires from the inlet control thermistor.
4. Remove the single Phillips-head screw, then lift and slide the thermistor from the heater assembly.

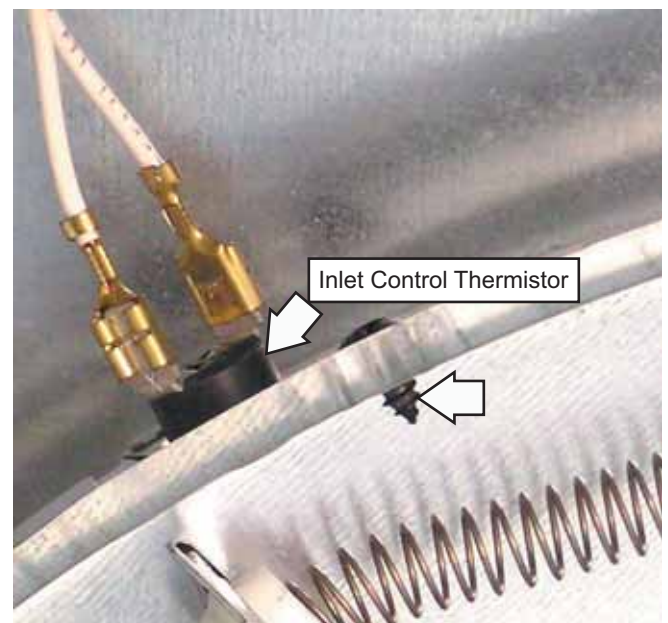

High Limit Thermostat

The high limit thermostat is located on the top right area of the heater housing. The high limit thermostat monitors incoming air temperature.

If the thermostat reaches a temperature beyond its maximum temperature rating, it will trip and disable power to the motor, elements, and the drum light.

The high limit thermostat opens at 315°F (157°C) and will automatically reset at 250°F (121°C).

To remove the inlet high limit thermostat:

1. Remove the top, control, and front panels. (See **Top Panel, Control Panel** and **Front Panel**.)
2. Remove the drum. (See **Drum**.)
3. Disconnect the 2 orange wires from the high limit thermostat.
4. Remove the single Phillips-head screw, then slide the thermostat from the heater assembly.



Outlet Control Thermistor

The outlet control thermistor is located on the lower rear area of the blower housing. It is below the outlet control backup thermostat. The outlet control thermistor measures outgoing air temperature and responds to temperature changes. The outlet control thermistor provides temperature change information to the power board. The power board makes heating decisions based on this information. The outlet control thermistor has the same resistance values as the inlet control thermistor. (See **Inlet Control Thermistor**.)

Operation of the outlet control thermistor can be checked by using service test mode t07. (See **Service Test Mode**.)

Specific failures associated with the outlet control thermistor can initiate error codes E03 and E05. (See **Service Test Mode**.)

To remove the outlet control thermistor:

1. Remove the top, control, and front panels. (See **Top Panel, Control Panel** and **Front Panel**.)
2. Remove the drum. (See **Drum**.)
3. Disconnect the 2 blue wires from the outlet control thermistor.
4. Remove the 2 Phillips-head screws that attach the outlet control thermistor to the blower housing.

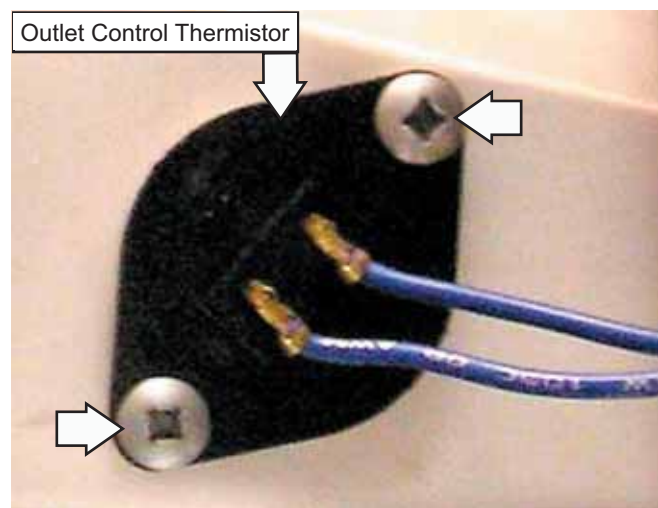

Outlet Control Backup Thermostat

The outlet control backup thermostat is located on the upper rear area of the blower housing. It is above the outlet control thermistor. The outlet control backup thermostat monitors the outgoing air temperature.

If the thermostat reaches a temperature beyond its maximum temperature rating, it will trip and disable power to the heating elements.

The outlet control backup thermostat opens at 165°F (74°C) and will automatically reset at 155°F (68°C).

To remove the outlet control backup thermostat:

1. Remove the top, control, and front panels. (See **Top Panel**, **Control Panel** and **Front Panel**.)
2. Remove the drum. (See **Drum**.)
3. Disconnect the red and orange wires from the outlet control backup thermostat.
4. Remove the single Phillips-head screw that attaches the outlet control backup thermostat to the blower housing.

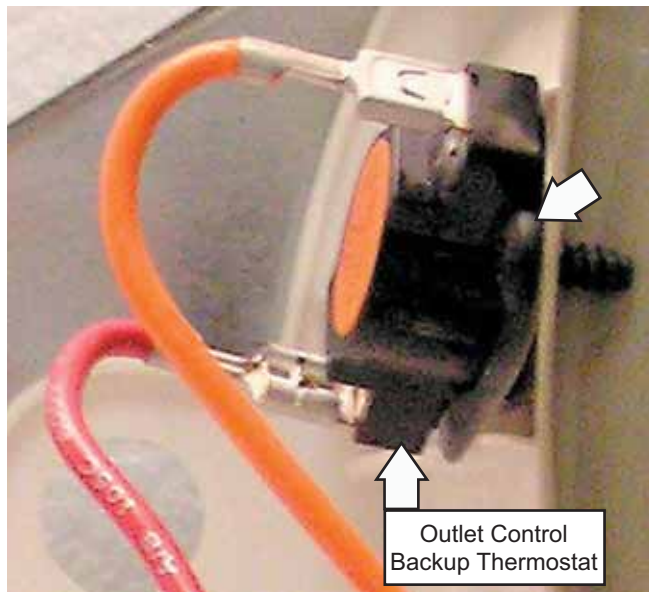

Drum Slide Assembly

The drum slide assembly is located on the back side of the front panel and utilizes 4 drum slides. Two white outer slides are used as guides, and 2 dark color center (top) slides are used to support the weight of the drum. When replacing the slides, the dark colored support slides must be replaced with the support slide replacements. Guide slides may also be replaced with support slides.

Caution: Do not replace the center (top) support slides with the white guide slides. Damage to the dryer will result. (See photo)

To remove the drum slide assembly:

1. Remove the top, control, and front panels. (See **Top Panel**, **Control Panel** and **Front Panel**.)
2. Grasp the top of the drum slide assembly and pull down and inward to release from the 2 tabs located at the top of the front panel.

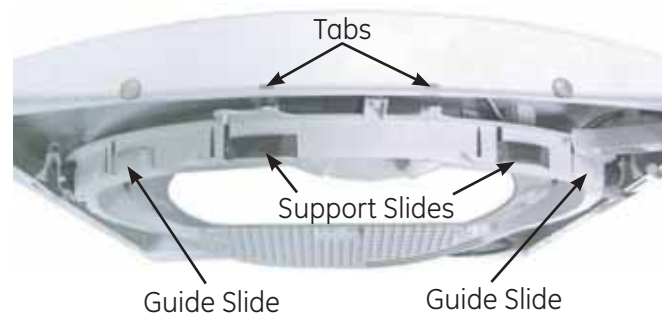

3. Remove the single Phillips-head screw that attaches the drum light receptacle and remove the receptacle from the drum glide assembly.

Caution: Upon reassembly, ensure that the door switch, drum light and sensor wiring are retained and routed properly to avoid contact with the drum.

Air Duct Assembly

The air duct assembly houses the lint filter, drum seal, and the 2 sensor rods. It is located on the back side of the front panel.

To remove the air duct assembly:

1. Remove the top, control, and front panels. (See **Top Panel**, **Control Panel** and **Front Panel**.)
2. Remove the drum slide assembly. (See **Drum Slide Assembly**.)
3. Remove the single Phillips-head screw that attaches the sensor ground wire to the cabinet.

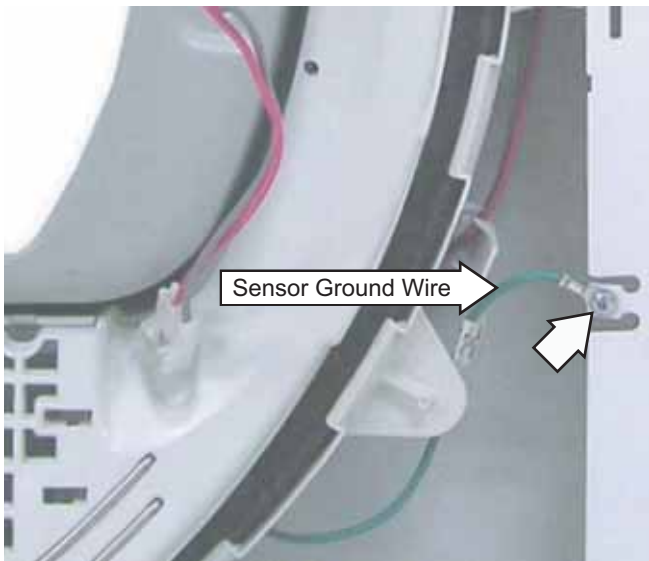

4. Remove the 2 Phillips-head screws that attach the air duct assembly to the front panel.



Note:

- The 2 sensor rods in the air duct assembly are not replaceable. To replace the sensor rods, replace the air duct assembly.
- The drum seal can be replaced by extracting the seal from the channel located on the air duct assembly.

Door Switch

The door switch is fastened to the front panel by 2 locking tabs and is common to all dryer functions. When the dryer door is closed, the switch will complete the motor circuit, allowing dryer operation. When the door is open, the switch will open the motor circuit, interrupting dryer operation. Opening the dryer door will also cause the door switch to close the drum light circuit, allowing the drum light to be energized.

Specific failures associated with the door switch can initiate error codes E03 and E05. (See **Service Test Mode**.)

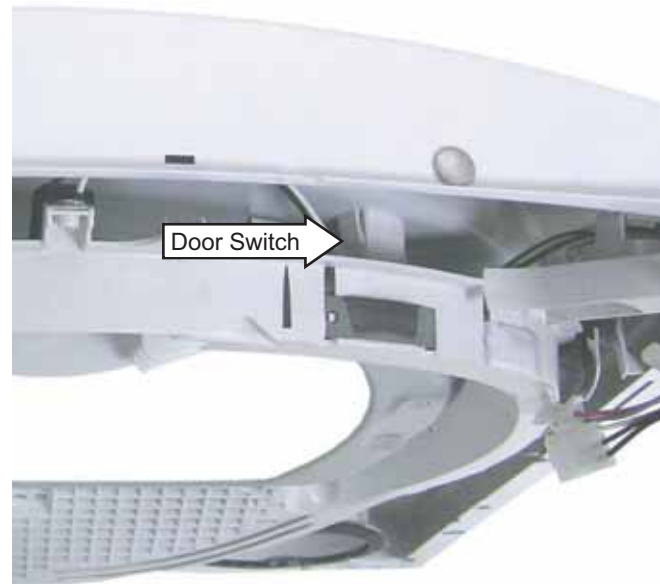

Moisture Sensor

The moisture-sensing circuit consists of 2 sensor rods. They are mounted beneath the lint filter on the drum side of the air duct.

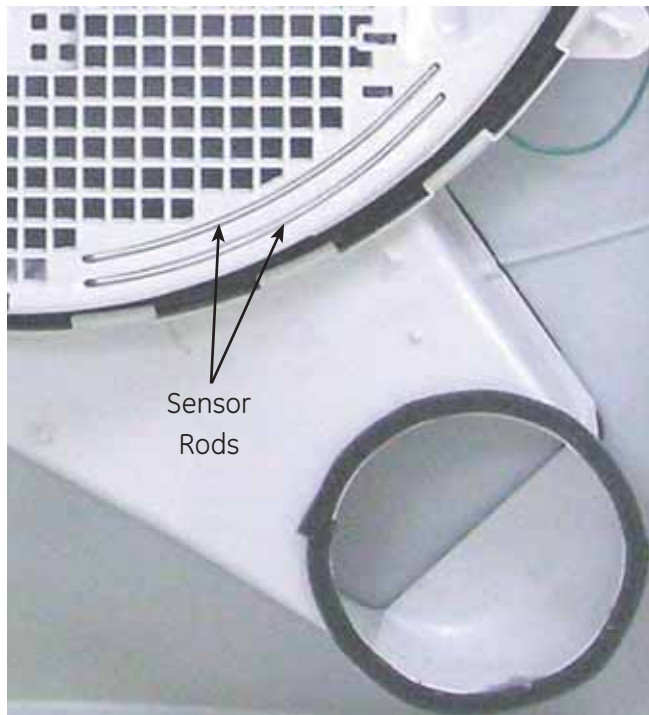

Note: The 2 sensor rods in the air duct assembly are not replaceable. To replace the sensor rods, replace the air duct assembly. (See **Air Duct Assembly**.)

- The sensor rods are connected to the main control board. The rods are spaced approximately ½-in. apart, which creates an open circuit to the control.
- The control board utilizes a low-voltage capacitor that charges to approximately 5 VDC when the circuit is open and discharges to less than 1 VDC when the circuit is shorted.
- When wet clothes tumble across the two rods, the clothes create a very low resistance between the rods, which discharges the capacitor.
- As the clothes become dry, their resistance value increases and the charge across the capacitor builds to approximately 5 VDC.
- Proper leveling of the dryer is vital for accurate sensor drying. If the front of the dryer is raised too high, clothes will tumble toward the rear of the drum, preventing contact with the sensor rods. This could produce a false dryness reading.

Power Board

The power board is mounted in a plastic housing that is attached to a bracket located under the top panel.

To remove the power board:

1. Remove the top panel. (See **Top Panel**.)
2. Remove the ribbon connector from power board connection CN110.
3. Remove the wire harness from the power board connections CN100, CN101, and CN111.
4. Remove the blue wire from power board connection TB100, and the 2 black wires from TB101.
5. On electric models, remove the single black wire from power board connection TB102, and the white wire from TB103.
6. Remove the 2 Phillips-head screws that attach the power board to the power board support.



Control Board Assembly

The control board assembly is mounted in a plastic housing that is attached to the inside of the control panel. It consists of 2 circuit boards connected by a ribbon. The boards and the plastic housing are replaced as an assembly.

Operation of the control board assembly can be checked by using the service test mode. (See **Service Test Mode**.)

Error codes that are specific to the control board can initiate error codes E01, E61, E80, and E81. (See **Service Test Mode**.)

To remove the control board assembly:

Caution: To avoid marring the control panel, place the panel face down on a protective surface.

1. Remove the top panel and the control panel. (See **Top Panel and Control Panel**.)
2. Remove the control knob by pulling outward.
3. Remove the plastic wire tie that attaches the control board ribbon to the control panel mounting bracket.
4. Remove the gasket seals from the right and left ends of the control panel mounting bracket.
5. Remove the 4 Phillips-head screws that attach the control panel mounting bracket to the control panel. Remove the bracket.

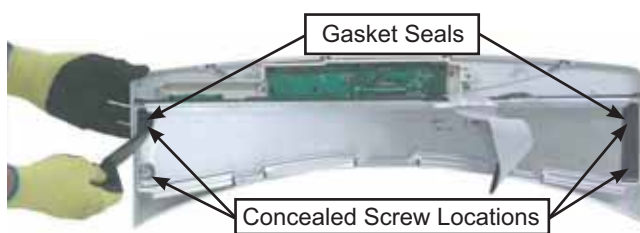

6. Remove the 3 Phillips-head screws that attach the control board assembly to the control board housing. Remove the control board.



Note: Each cycle selection button assembly is held to the plastic housing with a locking tab(s) and strut(s) system.

7. Press the locking tab(s) then carefully lift each cycle selection button to clear the strut(s) from the plastic housing.

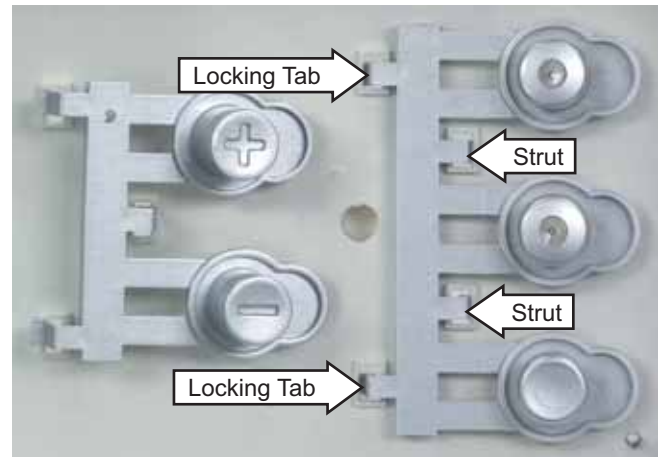

Note:

- The replacement control board will always enter into test mode t01 on initial power-up.
- If replacing the control board, the dryer will not function until the replacement control board has been programmed.

To program the replacement control board:

1. Reconnect power to the dryer. (The display will now show "---", which means no model has been selected.)
2. Rotate the cycle knob until the correct model number is displayed:
 - Select 1 for model DHDVH52EF/GF
 - Select 2 for model DBVH512EF/GF
 - Select 3 for model DCVH515EF/GF
3. Press and hold the Start/Pause key for 3 seconds. (The control will beep, indicating the new model number has been successfully programmed.)
4. Press the Power button to return to the test selection mode.

Note: If an error is made in programming the control, enter test mode and select T01. Then repeat steps 1 thru 3.

Service Test Mode

The dryer control has a service test mode that can be utilized by the service technician in order to test critical components and to access error codes. This test mode will help the service technician to quickly identify failed or improperly operating dryer components.

To enter the test mode:	To exit the test mode:
<ol style="list-style-type: none"> 1. Disconnect the power for 30 seconds. 2. Reconnect power and within 30 seconds of reconnecting power: <ol style="list-style-type: none"> a. Press signal button. b. Press delay start button. c. Press signal button. d. Press delay start button. (Displays t01) 	<p>Press the power button during the test selection mode.</p> <p>Note: A dryer left in the test mode will exit the test mode after a period of 30 minutes.</p>

Test Mode	Description
t01 Model ID	Verifies (or sets on new board) the proper model id.
t02 Error Codes	Lists up to 10 control-detected problems.
t03 Software ID	Displays the software version number and the non-volatile memory version number.
t04 Program Non-volatile Memory Test	Control computes and compares the 16-bit CRC of the non-volatile memory with the pre-computed version stored in the non-volatile memory.
t05 User Interface	Control turns on all LEDs and the 7-segment display.
t06 Keys Continuity	Verifies that all displays and buttons work.
t07 Outlet Thermistor	Displays outlet thermistor temperature.
t08 Inlet Thermistor	Displays inlet thermistor temperature.
t09 Moisture Sensor	Displays voltage read from the moisture sensor.
t10 Exhaust Detection	Verifies status of the exhaust system.

T e s t Mode	Press	Displays	Exit
t01	Start/ Pause	Displays UI model number (01-16) that corresponds to the UI model the control is currently configured for. Always displays "---" when no model is set in the control board. Proper model must be set when control board replaced. Rotate knob until desired UI model number is displayed (01-03), then press and hold Start/Pause until beep.	Press Power Returns to t01
t02	Start/ Pause	Displays the most recent error code. Control will store 8 error codes (E00=none). Press Start/Pause to clear each error code and display the next. Press and hold Start/Pause to clear all error codes (will then display E00).	Press Power Returns to t02
t03	Start/ Pause	Displays software and non-volatile revision numbers. Presents software revision number first. Press and hold Start/Pause to select non-volatile revision number.	Press Power Returns to t03
t04	Start/ Pause	Non-volatile memory test. The control will compute and compare the 16-bit CRC of the non-volatile memory with the pre-computed 16-bit CRC stored in the non-volatile memory. The control will sound the key press beep and display "EEP" after successful comparison, or sound the invalid key beep and display "Err" if unsuccessful.	Press Power Returns to t04
t05	Start/ Pause	Turns on all LEDs and the 7-segment display.	Press Power Returns to t05
t06	Start/ Pause	The control will sound a beep as long as any key is pressed.	Press Power Returns to t06
t07	Start/ Pause	Turns on motor and inner coil (electric) or burner (gas). Displays outlet thermistor temperature in degrees Fahrenheit.	Press Power Returns to t07
t08	Start/ Pause	Turns on motor and inner coil (electric) or burner (gas). Displays inlet thermistor temperature in degrees Fahrenheit.	Press Power Returns to t08
t09	Start/ Pause	Displays voltage read from the moisture sensor in volts.	Press Power Returns to t09
t10	Start/ Pause	Displays the condition of the exhaust system. The test takes approximately 2 minutes to complete. The control measures the rate of temperature increase through the inlet thermistor for a duration of 30 seconds. An acceptable increase is 48°F (9°C) for electric and 62°F (17°C) for gas. "LO" = exhaust too small or restricted. "HI" = exhaust adequate. (Note: "HOT" indicates the test was not completed normally. This test must be initiated when the inside of the dryer is cool).	Press Power Returns to t10

Error Codes

Error Code	Component, System, or Test	Description	Critical Failure
E00	All	No error	No
E01	EEPROM	EEPROM failure	Yes
E02	Inlet thermistor	Inlet thermistor short circuit	No
E03	Outlet thermistor	Outlet thermistor short circuit	No
E04	Inlet thermistor	Open circuit	No
E05	Outlet thermistor	Open circuit	No
E60	Door switch	Door switch malfunction	No
E61	Control board	L2 and N incorrectly wired (ac input too high)	Yes
E80	Control board	Invalid UI model	No
E81	Control board	Invalid power model	No

NOTE: It's important to note error codes should only be used to help identify those components which require testing. Never replace a part based solely on an error code. The control can generate a false error if the right conditions exist. Use the code only as a reference and always check the component before replacing.

Gas Model

WARNING: Disconnect electrical power before servicing.

Caution: Label all wires prior to disconnection. Wiring errors can cause improper and dangerous operation. Verify operation after servicing.

THERMOSTAT	TEMPERATURE F		TEMPERATURE C	
	OPEN	CLOSE	OPEN	CLOSE
OUTLET CONTROL BACKUP	165 ± 5	155 ± 5	74 ± 3	68 ± 3
INLET-SAFETY	300 ± 8	280 ± 12	149 ± 4	127 ± 7

RELAYS	MOTOR		DRY TEMPERATURE	
	K101-no	K100-no	ANTIBACTERIAL COPE WIDE/LSJ	NO HEAT COPE WIDE/LSJ
X	X	X	X	X
0	0	0	0	0

THERMISTORS RESISTANCE VALUES AT	
F	C
78 - 82	30
98 - 102	25
118 - 122	21

LEGEND
 X = CONTACTS ACTIVATED
 0 = CONTACTS DEACTIVATED
 TC = THERMISTOR CONTROLLED
 TMS = TRANSIENT VOLTAGE SUPPRESSOR

DANGER: DISCONNECT ELECTRIC POWER SUPPLY BEFORE SERVICING

CAUTION: LABEL ALL WIRES PRIOR TO DISCONNECTION WHEN SERVICING CONTROLS. WIRING ERRORS CAN CAUSE IMPROPER AND DANGEROUS OPERATION. VERIFY PROPER OPERATION AFTER SERVICING.

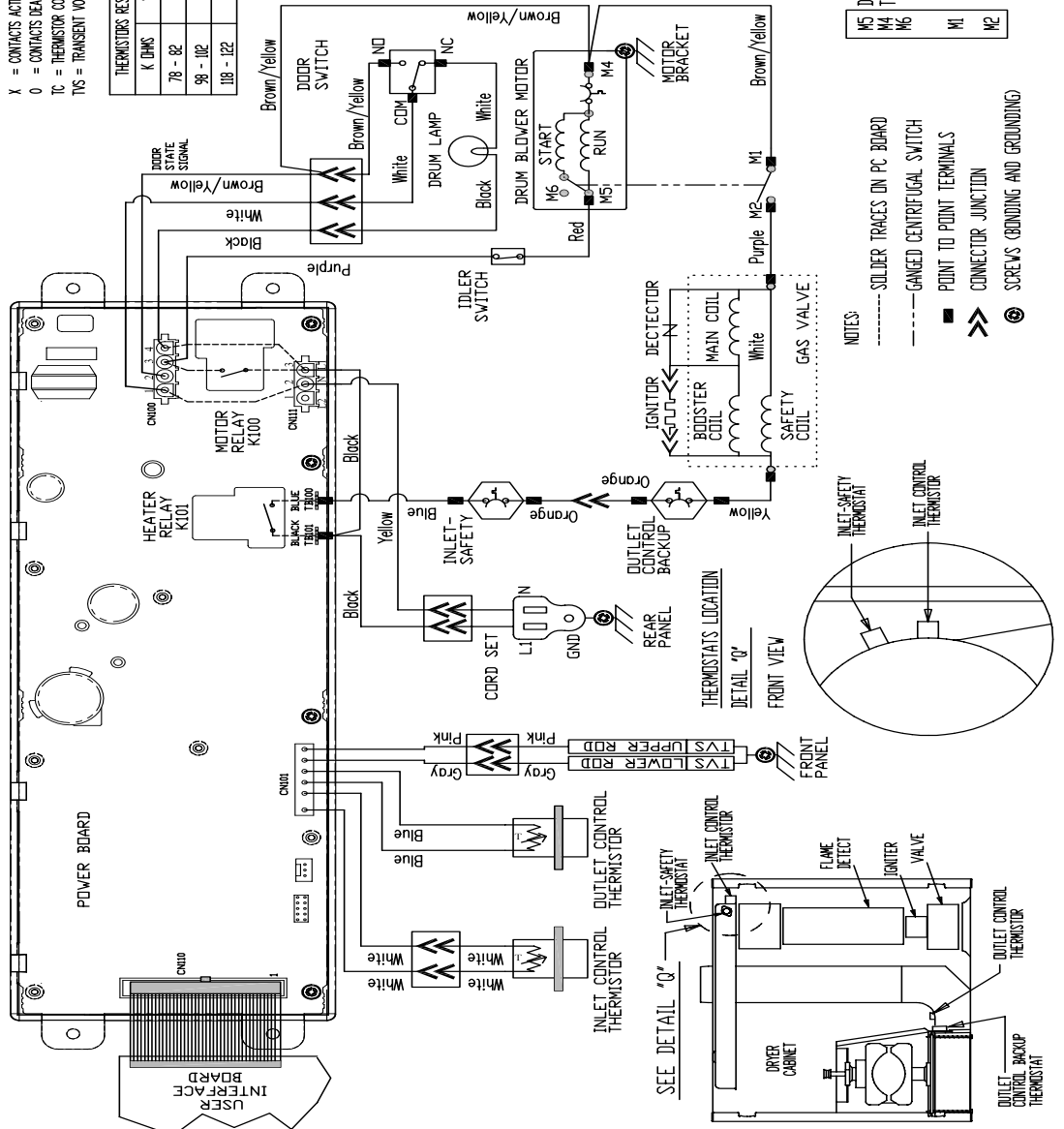

WHEN SERVICING THE DRYER

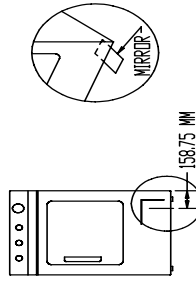

THE IGNITER FUNCTIONING AND THE FLAME CAN BE SEEN THROUGH A VIEWER HOLE LOCATED IN THE BASE OF THE DRYER. USE A MIRROR AS SHOWN IN THESE FIGURES.

P002 P002 P002 P002 P002 P002

M5 M4 M6 M1 M2
 M5 DRUM-BLOWER MOTOR
 M4 TAB SEQUENCE

NOTES:
 --- SOLDER TRACES ON PC BOARD
 --- GANGED CENTRIFUGAL SWITCH
 ■ POINT TO POINT TERMINALS
 ≡ CONNECTOR JUNCTION
 ⊕ SCREWS GROUNDING AND GROUNDING

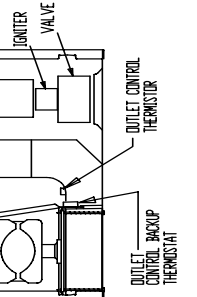
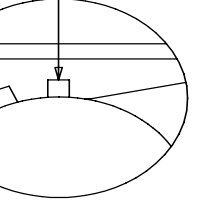

212D1204 P002
 PUB # 31-16123
 REV 0

Warranty



All warranty service provided by our Factory Service Centers, or an authorized Customer Care® technician. To schedule service, on-line, 24 hours a day, visit us at ge.com, or call 800.GE.CARES (800.432.2737).

Staple your receipt here.
Proof of the original purchase date is needed to obtain service under the warranty.

For The Period Of: We Will Replace:

One Year

From the date of the original purchase

Any part of the dryer which fails due to a defect in materials or workmanship. During this **full one-year warranty**, GE will also provide, **free of charge**, all labor and related service costs to replace the defective part.

What Is Not Covered:

- Service trips to your home to teach you how to use the product.
- Improper installation, delivery or maintenance.
- Failure of the product if it is abused, misused or used for other than the intended purpose or used commercially.
- Replacement of house fuses or resetting of circuit breakers.
- Damage to the product caused by accident, fire, floods or acts of God.
- Incidental or consequential damage caused by possible defects with this appliance.
- Damage caused after delivery.

This warranty is extended to the original purchaser and any succeeding owner for products purchased for home use within the USA. In Alaska, the warranty excludes the cost of shipping or service calls to your home.

Some states do not allow the exclusion or limitation of incidental or consequential damages. This warranty gives you specific legal rights, and you may also have other rights which vary from state to state. To know what your legal rights are, consult your local or state consumer affairs office or your state's Attorney General.

Warrantor: General Electric Company. Louisville, KY 40225