

WARNING

Electrical Shock Hazard

Disconnect from electric supply before servicing.
Failure to do so could result in death, electrical shock or other serious injury.

DIAGNOSTICS

Before servicing, perform the following checks:

- The most common cause for control failure is corrosion on connectors. Therefore, disconnecting and reconnecting wires will be necessary throughout test procedures.
- All tests/checks should be made with a VOM or DVM having a sensitivity of 20,000 ohms per volt DC or greater.
- Check all connections before replacing components, looking for broken or loose wires, defective terminals, or wires not pressed into connectors far enough.
- Voltage checks **must** be made with all connectors attached to the boards.
- Resistance checks **must** be made with power cord unplugged from outlet, and with wiring harness or connectors **disconnected**.

IMPORTANT

Electrostatic Discharge (ESD) Sensitive Electronics

ESD problems are present everywhere. ESD may damage or weaken the electronic control assembly. The new control assembly may appear to work well after repair is finished, but failure may occur at a later date due to ESD stress.

- Use an anti-static wrist strap. Connect wrist strap to green ground connection point or unpainted metal in the appliance
-OR-
Touch your finger repeatedly to a green ground connection point or unpainted metal in the appliance.
- Before removing the part from it's package, touch the anti-static bag to a green ground connection point or unpainted metal in the appliance.
- Avoid touching electronic parts or terminal contacts; handle electronic control assembly by edges only.
- When repackaging failed electronic control assembly in anti-static bag, observe above precautions.

PROBLEM: Bake Temperature Needs Adjustment

1. Press BAKE pad for 5 seconds. The default temp. 0° or a previously entered offset temp. will show in the Temp. Display.
 - Press the TEMP pad "up" arrow (⬆) to increase the temperature in 10° F or 5° C increments.
 - Press the TEMP pad "down" arrow (⬇) to decrease the temperature in 10° F or 5° C increments.

Maximum offset temperature adjustment is ±30° F or ±15° C.
2. Press the START pad to save the temp. adjustment.

Fahrenheit (° F) to Celsius (° C) Conversion

The default is Fahrenheit (° F).

1. Press the BROIL pad for 5 seconds. The temperature will be displayed in degrees Celsius indicated by the "C" in the temperature display.
2. To return the display to degrees Fahrenheit press the BROIL pad again for 5 seconds. "F" will show in the temperature display.

NOTES:

- Always disconnect power before touching internal parts of the oven!
- Upon replacement, immediately return old electronic oven control using the mailing label supplied with each new control.
- For double ovens, the failure code is displayed on the side of the display that corresponds to the oven with faulty part (upper oven = left side of display).





WARNING

Electrical Shock Hazard

Disconnect from electric supply before servicing.
Failure to do so could result in death, electrical shock or other serious injury.

FAILURE/ERROR DISPLAY CODES

FAULT CODE	ERROR CODE	CODE EXPLANATION	RECOMMENDED REPAIR PROCEDURE
F0	E0	Default F code -no failure	Will only be displayed if user presses and holds CANCEL key for 5 seconds and there is no pre-existing fault. Press CANCEL again to clear display.
F1	E3	Wiring harness cavity size does not match previously stored value	The "Cavity Size Select" jumpers in the wiring harness indicate a cavity size different from that which the control was previously configured for. Check the jumpers in the harness to make sure they agree with the actual oven size.
	All Other E Codes	Electronic control malfunction	Replace control if the E code is not E3.
F2	E2	Keypad not connected	1. Check keypad connector for firm connection. 2. Press CANCEL. If error code returns after 60 sec., replace keypad.
	E3	Key held down too long, or key is shorted	
F3	E0	Temperature sensor opened	1. Check sensor connection. 2. Measure sensor resistance (1080Ω at 70° F. Add 2Ω per degree.) 3. If resistance is not valid, replace sensor. 4. If sensor resistance and connections are good, then the oven cavity temperature must have exceeded a safe level. Check for welded-closed relays on the control.
	E1	Temperature sensor shorted	
F5	E1	Self-clean latch will not lock	1. Check the latch assembly: latch arm pivot joint, arm/solenoid connection, solenoid spring, and spring washer. 2. Check the Latch Solenoid: - Check for firm electrical connections. - Disconnect the two wires from the solenoid and measure the resistance of the solenoid. A small resistance (approx. 175Ω) is normal. If the solenoid is open (∞Ω) or shorted (0Ω), it should be replaced. 3. Check the Latch Switch. Disconnect it and use a continuity tester: - Door latched = switch closed, continuity should read 0Ω. - Door unlatched = switch open, continuity should read ∞Ω. 4. Check Door Open/Closed Switch. Disconnect it and use a continuity tester: - Door open = switch closed, continuity should read 0Ω. - Door closed = switch open, continuity should read ∞Ω.
	E6	Door is open, but latch is locked	
	E7	Self-clean latch will not unlock	
F7	E1	Common switch wire is defective	Common wire (+5VDC) to latch switch, and to door switch is shorted to chassis ground or neutral. A double oven will have two of each switch and one common wire. 1. Check connections at control and at the latch switch and door switch. 2. If all connections are good, then check the individual switches as outlined for the F5 failure.

WIRE HARNESS SCHEMATIC

NOTES:

WHEN REPLACING THE ELECTRONIC CONTROL, BE SURE TO ATTACH THE CAVITY SELECT LINE TO THE PROPER TERMINAL (SEE "CAVITY SIZE" TABLE BELOW).

DOTS INDICATE CONNECTIONS OR SPLICES.

CIRCUIT SHOWN IN STANDBY/OFF MODE WITH OVEN DOOR CLOSED.

THERMAL FUSE/T.O.D.		LIGHT		HEATING ELEMENT	
GROUND (CHASSIS)		AC DRIVE MOTOR		SOLENOID	
PLUG WITH FEMALE CONNECTOR		RELAY COIL		ENCLOSED THERMISTOR	
RECEPTACLE WITH MALE CONNECTOR		RELAY CONTACTS		OPERATED BY DOOR	

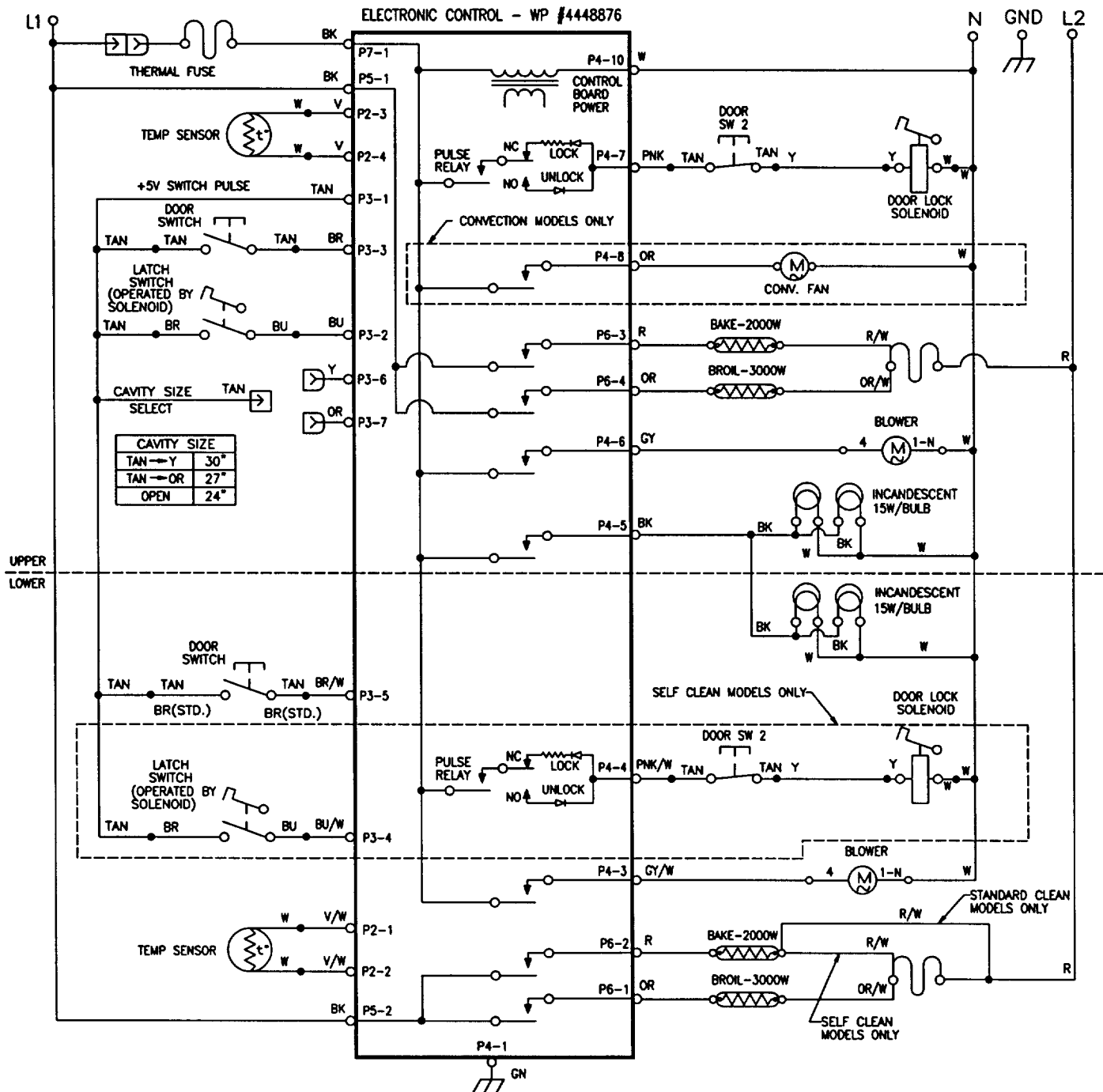

HARNES DIAGRAM

NOTE: Actual connector locations may differ

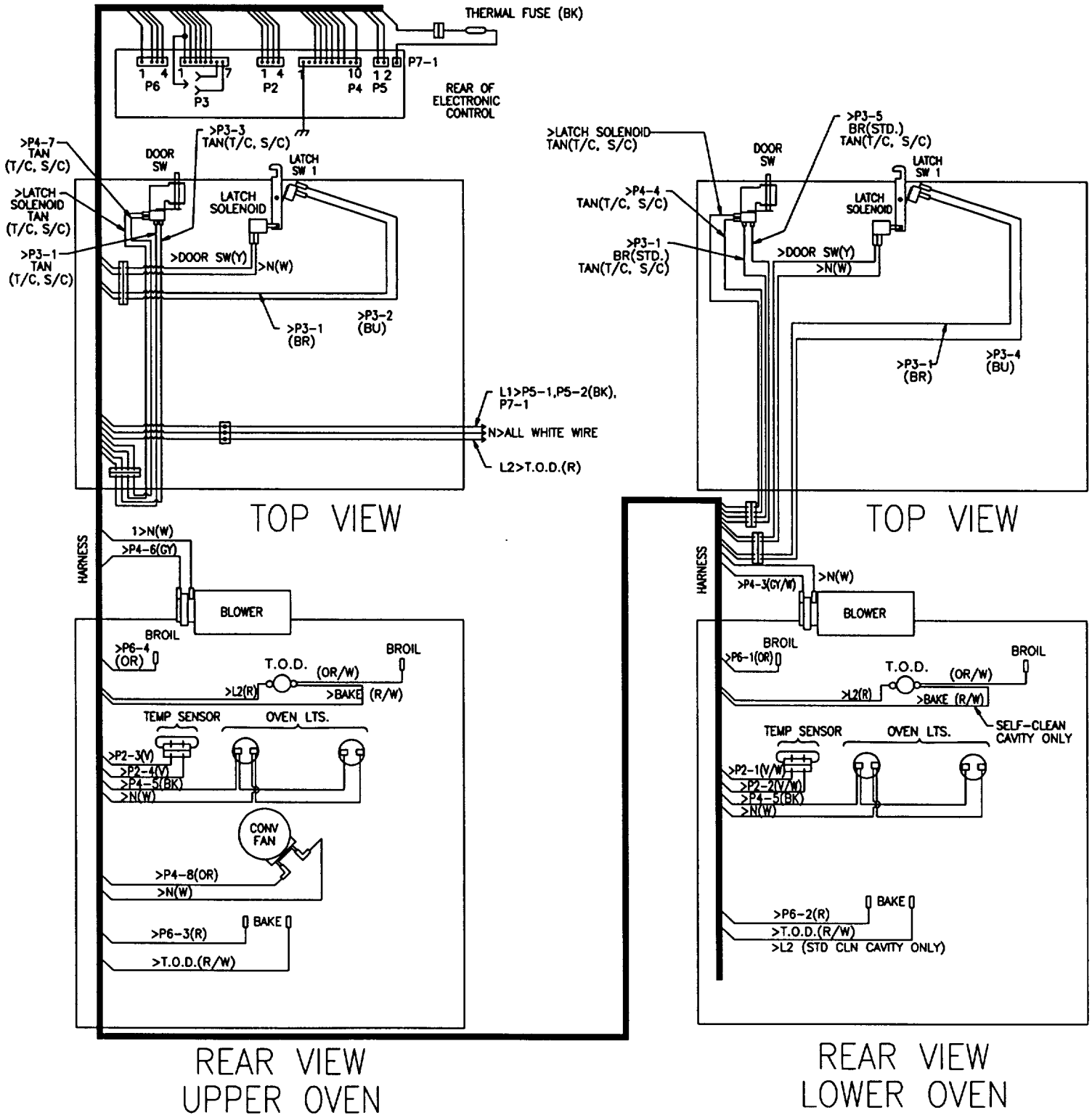

UPPER OVEN COMPONENTS

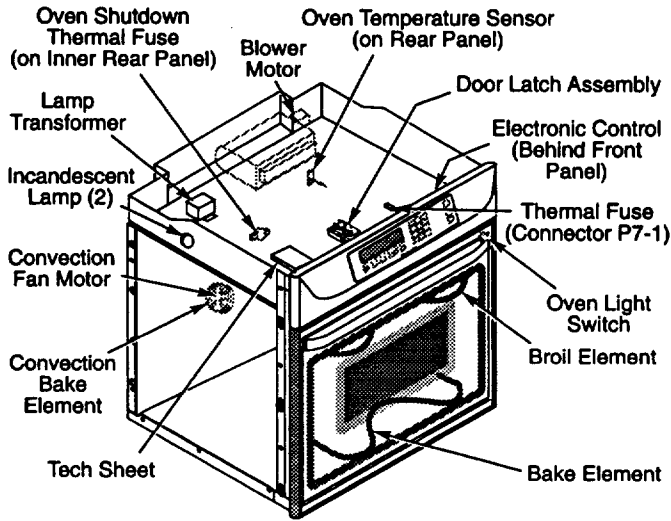

LOWER OVEN COMPONENTS

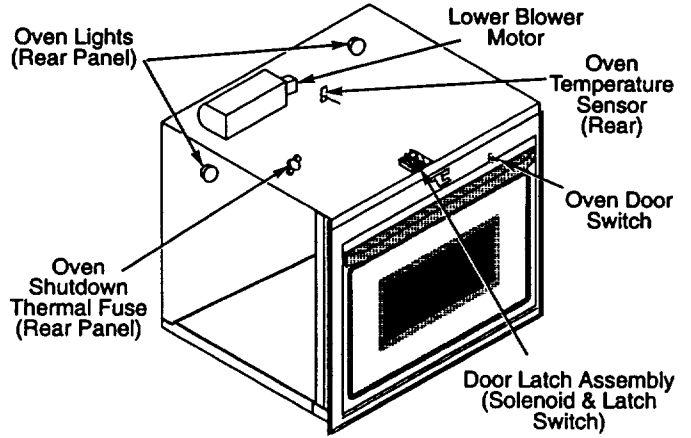

ELECTRONIC CONTROL PINOUTS		
PIN	FUNCTION	COLOR
P6-1	BROIL LOWER	OR
ROUND		
P6-2	BAKE LOWER	R
P6-3	BAKE UPPER	R
P6-4	BROIL UPPER	OR
P3-1	+5 V SWITCH PULSE	TAN
P3-2	LATCH SWITCH UPPER	BU
P3-3	DOOR SWITCH UPPER	BR
P3-4	LATCH SWITCH LOWER	BU/W
P3-5	DOOR SWITCH LOWER	BR/W
P3-6	30" SELECT	Y
P3-7	27" SELECT	OR
P4-1	EARTH GROUND	GN
P4-2	NOT CONNECTED	
P4-3	COOLING FAN LOWER	GY/W
P4-4	LATCH SOLENOID LOWER	PNK/W
P4-5	LIGHTS	BK
P4-6	COOLING FAN UPPER	GY
P4-7	LATCH SOLENOID UPPER	PNK
P4-8	CONVECTION FAN UPPER	OR
P4-9	NOT CONNECTED	
P4-10	NEUTRAL	W
P2-1	TEMP SENSOR LOWER	V/W
P2-2	TEMP SENSOR LOWER	V/W
P2-3	TEMP SENSOR UPPER	V
P2-4	TEMP SENSOR UPPER	V
P5-1	L1	BK
P5-2	L1	BK
P7-1	L1	BK
P7-2	NOT CONNECTED	

ELECTRICAL COMPONENTS KEY

OVEN COMPONENT	FRONT / REAR SERVICEABLE
ELECTRONIC CONTROL	FRONT
MEMBRANE SWITCH	FRONT
DOOR SWITCHES	FRONT
LATCH SWITCH	FRONT
LATCH SOLENOID	FRONT
OVEN TEMPERATURE SENSORS	FRONT
BAKE ELEMENTS	FRONT
CONSOLE BLOWERS	REAR
BROIL ELEMENTS	FRONT
INCANDESCENT LIGHTS	LIGHT BULB - FRONT LIGHT ASSY. - REAR
CONVECTION FAN MOTORS	REAR
THERMAL FUSE T.O.D.	REAR

RELAY LOGIC UPPER AND LOWER OVEN

MODES	RELAYS	BAKE	BROIL	CONV FAN	OV LT	BLOWER	PULSE RELAY	LOCK/UNLOCK
OFF	○	○	○	⊗	⊗	○	○	○
■ PREHEAT-BAKE	+	+	○	⊗	X	○	○	○
BAKE 24",27" ■	+	+	○	⊗	X	○	○	○
BAKE 30" ■	X	+	○	⊗	X	○	○	○
BROIL 24" ○	○	+	○	⊗	X	○	○	○
BROIL 27",30" ○	○	X	○	⊗	X	○	○	○
● PREHEAT-CONV	X	+	X	⊗	X	○	○	○
CONV ●	+	+	X	⊗	X	○	○	○
▲ PREHEAT-CLEAN	+	X	○	○	X	*	*	*
CLEAN ▲	X	+	○	○	X	○	○	○

RELAY LOGIC KEY

- - OFF
- X - ON
- + - CYCLING (MAX PERIOD=60 SEC)
- ⊗ - ON OR OFF
- * - PULSED FOR 1/2 SEC

OVEN STRIP CIRCUITS

The following individual circuits are for use in diagnosis.
 Before starting diagnosis, check the line voltage and for blown fuses.

NOTE: Pin numbers shown in parentheses () denotes lower oven connections.

BAKE AND PREHEAT BAKE

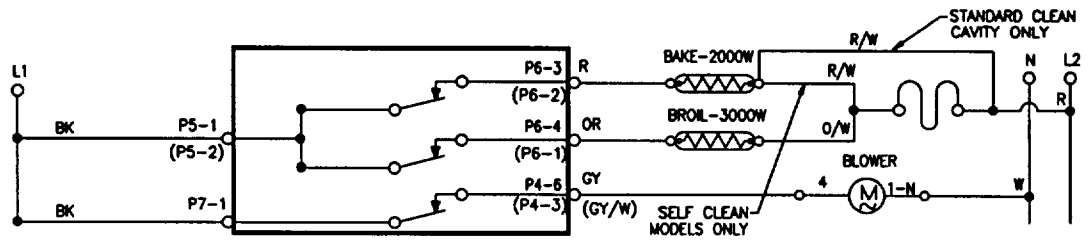

BROIL

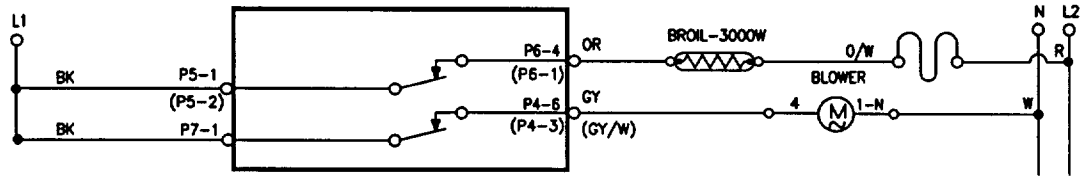

CONVECTION AND PREHEAT CONVECTION

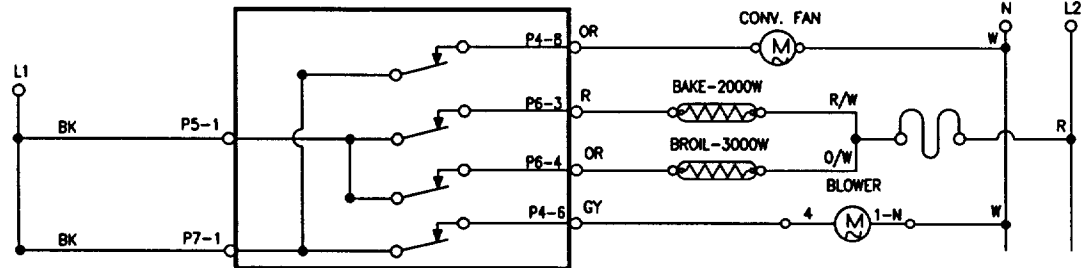

CLEAN (Above 600°F)

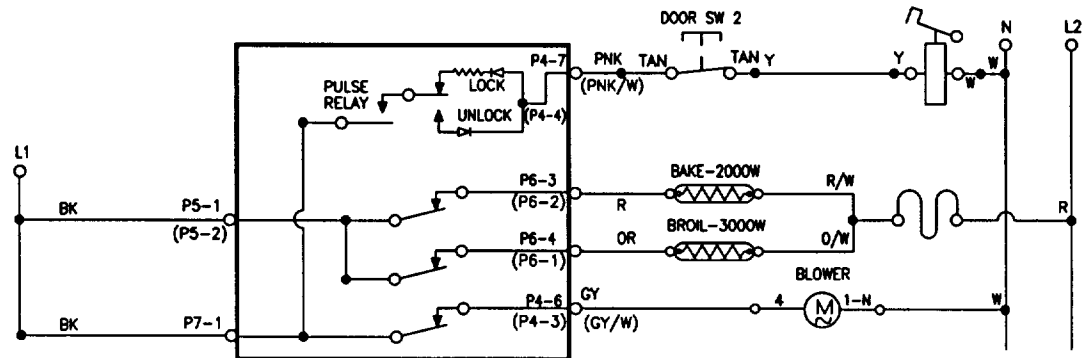

PREHEAT CLEAN

(Below 600°F)

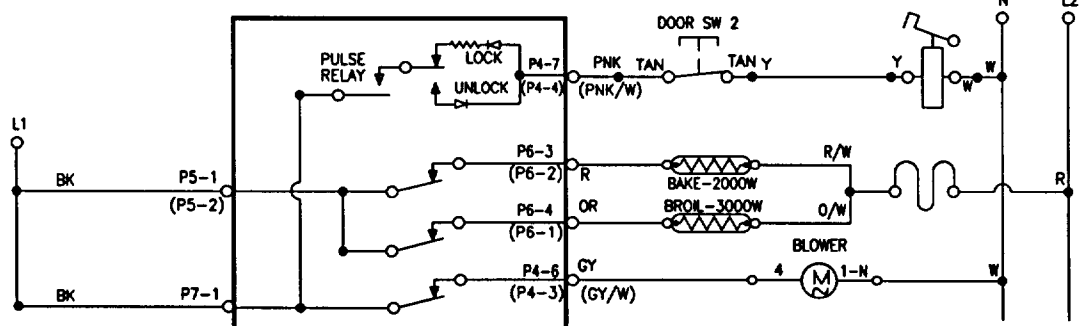

OVEN SHUTDOWN THERMAL FUSE

The oven shutdown thermal fuse is located at the back of the oven. It will shut down the elements if the temperature at the back of the oven reaches the following temperatures:

Upper oven opens at 338°F (170°C). Lower oven opens at 302°F (150°C).

Verify that the Oven Shutdown Thermal Fuse is okay.

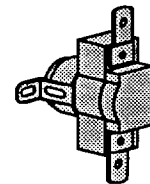

THE FOLLOWING COMPONENTS CAN BE TESTED AT THE CONTROL PANEL:

LOWER OVEN			
COMPONENTS	FRONT/REAR SERVICEABLE	CHECK POINTS	RESULTS
Door Switch*	Front	P3-5 (BR/W) to P3-1 (TAN)	Door Open = Closed Circuit Door Closed = Open Circuit
Door Lock Solenoid (with Door Closed)	Front	P4-4 (PNK/W) to Neutral (W)	50 Ω
Oven Temperature Sensor	Front	Sensor P2-2 (V) to P2-1 (V)	1080 Ω @ 70°F
Blower (Low Speed)	Rear	P4-3 (GY/W) to Neutral (W)	10 Ω to 15 Ω
Oven Shutdown Thermal Fuse	Rear	P6-2 (R) to Red Wire at Terminal Block or P6-1 (OR) to Red Wire at Terminal Block	Closed Circuit
Bake Element	Front	P6-2 (R) to Red Wire at Terminal Block	25 Ω to 30 Ω
Broil Element	Front	P6-1 (OR) to Red Wire at Terminal Block	45 Ω to 55 Ω
Latch Switch	Front	P3-4 (BU/W) to P3-1 (TAN)	Door Unlocked = Open Circuit Door Locked = Closed Circuit

UPPER OVEN			
COMPONENTS	FRONT/REAR SERVICEABLE	CHECK POINTS	RESULTS
Door Switch*	Front	P3-3 (BR) to P3-1 (TAN)	Door Open = Closed Circuit Door Closed = Open Circuit
Door Lock Solenoid (with Door Closed)	Front	P4-4 (PNK) to Neutral (W)	50 Ω
Oven Temperature Sensor	Front	Sensor P2-3 (V) to P2-4 (V)	1080 Ω @ 70°F
Blower	Rear	P4-6 (GY) to Neutral (W)	10 Ω to 15 Ω
Oven Light Transformer	Front	Primary Winding Secondary Winding	40 Ω to 45 Ω Less than 1 Ω
Oven Shutdown Thermal Fuse	Rear	P6-3 (R) to Red Wire at Terminal Block or P6-4 (OR) to Red Wire at Terminal Block	Closed Circuit
Bake Element	Front	P6-3 (R) to Red Wire at Terminal Block	25 Ω to 30 Ω
Broil Element	Front	P6-4 (OR) to Red Wire at Terminal Block	45 Ω to 55 Ω
Convection Fan Motor	Rear	P4-8 (OR) to Neutral (W)	8 Ω to 12 Ω
Control Panel Thermal Fuse	Front	L1 (BK) to P7-1 (BK)	Closed Circuit
Latch Switch	Front	P3-4 (BU) to P3-1 (TAN)	Door Unlocked = Open Circuit Door Locked = Closed Circuit

POSSIBLE SERVICE PROBLEM:

* **Door Switch** - Acts as a logic switch that signals the microcomputer board that the oven door is open or closed. If the door switch does not signal the board that the door is in the correct position (closed) during a cycle, the broil element will shut off immediately, and/or the bake element will shut off within 2 minutes.

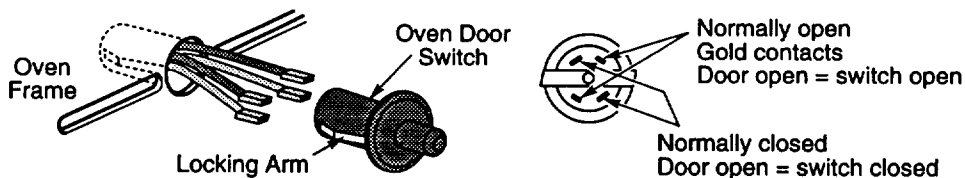

MANUFACTURED UNDER ONE OR MORE OF THE FOLLOWING
UNITED STATES PATENTS:

4,102,322

4,364,589

4,467,184

OTHER PATENTS PENDING

PART NO. 4454767 REV. B

NOTE: This sheet contains important
Technical Service Data

**FOR SERVICE TECHNICIAN ONLY
DO NOT REMOVE OR DESTROY**