

# Double Oven Gas Range—Technical Information

## MGR6775BD\*

- Due to possibility of personal injury or property damage, always contact an authorized technician for servicing or repair of this unit.
- Refer to Service Manual 16023415 for detailed installation, operating, testing, troubleshooting, and disassembly instructions.



### CAUTION

All safety information must be followed as provided in Service Manual 16023415.



### WARNING

To avoid risk of electrical shock, personal injury or death; disconnect power and gas to range before servicing, unless testing requires power and/or gas.





Model		MGR6775BD*	Model		MGR6775BD*
<b>Power Source</b>			<b>Features</b>		
Voltage rating	120 VAC		One piece cast iron burner grates	YES	
Amperage rating	15 Amp		Frameless glass door with window	YES	
Frequency	60 Hz		Interior oven light	YES	
<b>Water Column Pressure</b>			Two ovens	YES	
Natural	5 in. W.C.P.		Two self-cleaning porcelain ovens	YES	
LP/Propane	10 in. W.C.P.		Electronic range control	YES	
<b>Surface Burner (BTU Nat. / LP)</b>			High performance burners	YES	
Small	5,000 / 4,000		Recessed broiler	YES	
Medium	9,200 / 9,100				
Large	12,000 / 10,000		<b>Product Exterior Dimensions in. (cm)</b>		
X-Large	16,000 / 14,000		Height overall	46 3/4 (118.7)	
<b>Oven Burner (BTU Nat. / LP)</b>			Width	29 7/8 (75.9)	
Bake (lower oven)	16,000 (16,000)		Depth oven door closed with handle	28 5/8 (72.7)	
Bake & Broil (upper oven)	10,000 (10,000)		Clearance oven door	21 1/2 (54.6)	
<b>Oven Interior Dimensions in. (cm)</b>			Height of cooktop	35 7/8 (91.1)	
Height	9 1/2 (24.1) upper	16 1/2 (42) lower			
Width	20 1/2 (52) upper	23 (58) lower	<b>Weight lbs. (kg)</b>		
Depth	19 1/4 (49) upper	18 1/8 (46) lower	Approximate shipping weight	255 (115.7)	

# Component Testing Procedures

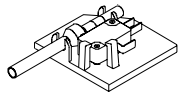
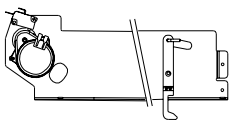
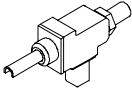

## WARNING

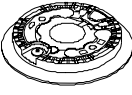
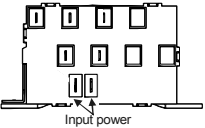
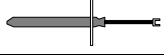
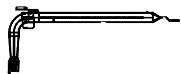
To avoid risk of electrical shock, personal injury or death; disconnect power and gas to range before servicing, unless testing requires power and/or gas.

Illustration	Component	Test Procedure	Results
	Oven light housing	Disconnect connector and test resistance of terminals .....  Measure voltage at oven light .....	Continuity with known good bulb inserted.  120 VAC, see wiring diagram for terminal identification. If voltage is not present at oven light, check wiring or light switches.
	Door plunger switch	Remove switch from unit and measure from C to NO.....	<b>Plunger in:</b> ..... Continuity. <b>Plunger out:</b> ..... Infinite.
	Autolatch assembly with switch	Disconnect wires and test for continuity per wiring diagram  Refer to Parts Manual for correct autolatch switch associated with the correct manufacturing number.	See wiring diagram for schematic layout.
	270° valve 5 K btu 9.2 K btu 12 K btu 16 K btu	Verify gas is supplied .....  Adjust set screw for simmer control.	Gas is supplied.
	Spark 270° switch	Test for voltage at terminals .....  Disconnect wiring and check for continuity in LITE position .....	120 VAC.  Continuity in LITE position.
	Spark ignition electrode	Test for resistance of spark lead .....  Test ignitor to chassis .....	Continuity.  No continuity from ignitor to chassis.
	Top surface burner 5 K btu 9.2 K btu 12 K btu 16 K btu	Verify gas is supplied .....  Verify burner cap is positioned correctly.	Check for obstructions in burner ports.
	Spark module 4 + 0	Test for voltage at terminals L and N .....  Check polarity and ground .....	120 VAC.  See wiring diagram.
	Temperature sensor	Measure resistances .....	Approximately 1100 Ω at room temperature 75° F.
	Bake burner	Verify gas is supplied.  Orifice adjusted for Natural or LP .....  Check for obstructions or contamination in ports .....	<b>Set for Natural Gas from the factory.</b>  Adjust as necessary.  Replace if punctured or torn.
	Broil burner	Verify gas is supplied.  Orifice adjusted for Natural or LP .....  Check for obstructions or contamination in ports .....	<b>Set for Natural Gas from the factory</b>  Adjust as necessary.  Replace if punctured or torn.
	Ignitor	Test for voltage at terminals .....  Test for the amount of amperage in the circuit ..... (Ignitor may glow but not have sufficient amperage to open valve).	120 VAC.  3.2 - 3.6 Amps. If not, replace.

# Component & Control Testing Procedures



## WARNING

To avoid risk of electrical shock, personal injury or death; disconnect power and gas to range before servicing, unless testing requires power and/or gas.

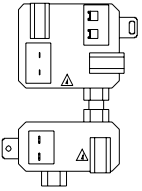
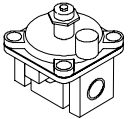
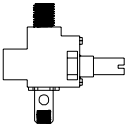
Illustration	Component	Test Procedure	Results
	Triple thermal valve	Disconnect wiring to valve. Measure resistance on upper and lower bake circuit..... Measure resistance on broil circuit .....	Continuity. If not, replace. Continuity. If not, replace. <div style="border: 1px solid black; padding: 5px; text-align: center;"><b>WARNING</b> Do not attempt to open valve with 120 VAC.</div>
	Pressure regulator	Verify gas pressure (W.C.P.)..... If on LP service, verify proper gas supply conversion.	5" Natural. 10" LP/propane.
	Shut off valve	Verify gas supply is turned on..... Located on surface valve manifold near maintop upsweep.	<b>Gas ON:</b> .....Slot at 9 o'clock position. <b>Gas OFF:</b> .....Slot at 12 o'clock position.
	Power cord 3-wire	Verify resistance of wires to terminals ...	Continuity.
Control	Feature	Procedure	Results
H3	Oven temperature adjustment (Upper Oven)	Press <b>Upper Bake</b> pad. Enter <b>550</b> on the digit-pad. Immediately press and hold <b>Upper Bake</b> pad for 3 to 5 seconds. Oven can be adjusted from -35 to +35 degrees in 5-degree increments by pressing <b>More+</b> or <b>Less-</b> pads. To avoid over adjusting the oven, move temperature 5 degrees each time. Wait 4 seconds for the data entry timer to expire to accept the change. Temperature adjustment will be retained even through a power failure.	While increasing or decreasing oven temperature, this does not affect self-cleaning temperature.
H3	Oven temperature adjustment (Lower Oven)	Press <b>Lower Bake</b> pad. Enter <b>550</b> on the digit-pad. Immediately press and hold <b>Lower Bake</b> pad for 3 to 5 seconds. Oven can be adjusted from -35 to +35 degrees in 5-degree increments by pressing <b>More+</b> or <b>Less-</b> pads. To avoid over adjusting the oven, move temperature 5 degrees each time. Wait 4 seconds for the data entry timer to expire to accept the change. Temperature adjustment will be retained even through a power failure.	While increasing or decreasing oven temperature, this does not affect self-cleaning temperature.

# Control Testing Procedures



## WARNING

To avoid risk of electrical shock, personal injury or death; disconnect power and gas to range before servicing, unless testing requires power and/or gas.

Control	Feature	Procedure	Results
H3	Temperature display	Press and hold <b>Upper Cancel</b> and <b>Upper Bake</b> pads for 3 to 5 seconds.	Indicates °F or °C on the display.
H3	Factory Default	Press and hold <b>Upper Cancel</b> and <b>Warm</b> pads for 3 to 5 seconds.	Resets control to factory settings.
H3	Clock Display	Press and hold <b>Upper Cancel</b> and <b>Clock</b> pads for 3 to 5 seconds.	Turns clock display on or off.
H3	24 Hour Clock	Press and hold <b>Upper Cancel</b> and <b>Delay</b> pads for 3 to 5 seconds.	Displays either 12-hour or 24-hour time format.
H3	Demo	Press and hold <b>Upper Cancel</b> and <b>Less -</b> pads for 3 to 5 seconds.	Enters a demonstrative sales mode.
H3	Twelve hour off	Control will automatically cancel any cooking operation and remove all relay drives 12 hours after the last pad touch.	See Sabbath mode to disable.
H3	Sabbath Mode	Hold <b>Clock</b> pad for 3 to 5 seconds to activate Sabbath mode. Hold <b>Clock</b> pad for 3 to 5 seconds to disable Sabbath mode. Oven must be in BAKE mode before enabling SABBATH.	"SAb" displays and flashes for 5 seconds. All pad inputs are disabled except for <b>CANCEL</b> and <b>CLOCK</b> pads. This mode disables the normal 12 hour shutoff to allow operation of the bake mode for a maximum of 72 hours.
H3	Beeper Volume	Hold <b>Upper Cancel</b> and <b>More+</b> pads for 3 to 5 seconds to adjust beeper loudness level.	Volume settings are Low, Medium and High.
H3	Child lock out	Press and hold <b>Upper Cancel</b> and <b>Cook &amp; Hold</b> pads for 3 to 5 seconds. "OFF" will display where the temperature normally appears. "LOCK" will display flashing while door is locking. To reactivate the control, press and hold <b>Cancel</b> and <b>Cook &amp; Hold</b> pads for 3 to 5 seconds.	This disables the electronic oven control and prevents children from accidentally programming the oven.  Child lockout features must be reset after a power failure.
H3	Diagnostic Code Display	Press and hold <b>Upper Cancel</b> and <b>Timer</b> for 3 to 5 seconds within 5 minutes of power up. See "Quick Test Mode." Cycle through the codes.	The last 5 diagnostic codes will be stored in the non-volatile memory.  See "Description of Error Codes" for explanation.

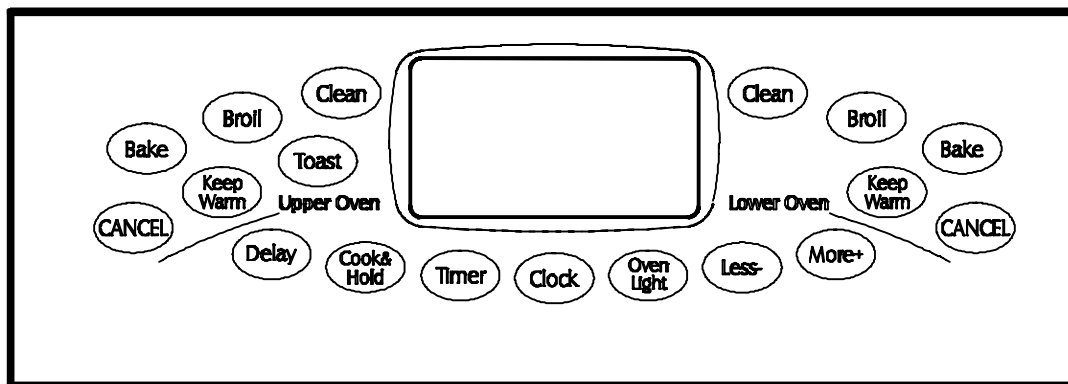

# Control Testing Procedures



## WARNING

To avoid risk of electrical shock, personal injury or death; disconnect power and gas to range before servicing, unless testing requires power and/or gas.

### Relay Logic

Subsequent changes implemented after the release of this technical sheet may have altered the parameter identified in this chart.

	BAKE	BROIL	CONVECT ELEMENT	OVEN LIGHT
<b>COOKING MODE</b>				
IDLE	X	X	X	◇
BAKE PREHEAT	■	■	X	◇
BAKE	■	■	X	◇
BROIL PREHEAT	X	■	X	◇
BROIL	X	■	X	◇
CLEAN PREHEAT	■	■	X	X
CLEAN	■	■	X	X
KEEP WARM	■	X	X	◇

### INDEX

X - OFF

■ - CYCLING

◇ - ON OR OFF (DETERMINED BY USER INPUT)

# Control Testing Procedures



## WARNING

To avoid risk of electrical shock, personal injury or death; disconnect power and gas to range before servicing, unless testing requires power and/or gas.

### "Quick Test" Mode for Electronic Range Control

Follow the procedure below to perform the Electronic Range Control (ERC) quick test. Instructions must be entered within 32 seconds of each other (via the touch pad) or the ERC will exit the quick test.

1. **Press and hold** *UPPER CANCEL* and *BROIL* pads for 3 to 5 seconds.
2. Once the control has entered the "Quick Test" mode, release both pads.
3. Press each of the following pads indicated in the table below.

**NOTE:** Press the applicable pad once to activate the associated response.  
Press the applicable pad a second time to deactivate the associated response.

#### Display will indicate the following:

Pad	Response
UPPER BAKE .....	Upper Bake DLB and Upper Bake relay activated
LOWER BAKE .....	Lower Bake DLB and Lower Bake relay activated
TOAST .....	DLB relays activated
UPPER BROIL .....	Upper Broil DLB and Upper Broil relay activated
LOWER BROIL .....	Lower Broil DLB and Lower Broil relay activated
UPPER KEEP WARM.....	Motorized Door Lock - Upper
LOWER KEEP WARM.....	Motorized Door Lock - Lower
OVEN LIGHT .....	Oven lights activated
COOK & HOLD .....	Displays last diagnostic code
LESS (-) .....	Displays EEPROM version number
MORE (+).....	Displays main code version number
CLOCK.....	All display segments illuminated

### Description of Error Codes

The Diagnostic Code Display Mode allows viewing of the error diagnostic codes. Each error code consists of four digits. The following table describes the function of each digit.

Digit	Description
1 <sup>st</sup>	Primary System: 1 – Local to the control circuit board 3 – Sensor or meat probe 4 – Control input 9 – Door lock
2 <sup>nd</sup>	Error Type: d – Diagnostic: measurable parameter c – Control related, replace control
3 <sup>rd</sup>	Secondary System: Sequential numbering
4 <sup>th</sup>	Oven Cavity: 1 – Upper oven (or single cavity oven) 2 – Lower oven c – Control specific

Diagnostic Code Display Mode is accessed via the Quick Test Mode. To view the last 5 error codes, enter the Quick Test Mode by **pressing and holding** the *UPPER CANCEL* and *UPPER BROIL* pads for 3 to 5 seconds within 5 minutes of power-up. **Diagnostic Code Display Mode may be activated only when applying power to the control.**

# Control Testing Procedures



## WARNING

To avoid risk of electrical shock, personal injury or death; disconnect power and gas to range before servicing, unless testing requires power and/or gas.

### Diagnostic Code Checking

Code	Description	When Checked	Detection
1c1c	Shorted key	Always	1 minute
1c2c	Keyboard tail disconnected	Always	1 minute
1c31	Cancel key circuit problem	Always	20 seconds
1c32	Cancel key circuit problem	Always	20 seconds
1c4c	Micro Communication Failure	Always	1 minute
1c5c	VCC or ground	Always	1 minute
1c6c	EEPROM error	When accessing EEPROM	3 tries
1c7c	Control not calibrated	Always	3 tries
1c8c	Cooking program error	Cook or clean programmed	3 tries
1d11	Runaway temp (650° F), door unlocked	Latch unlocked	1 minute
1d12	Runaway temp (650° F), door unlocked	Latch unlocked	1 minute
1d21	Runaway temp (950° F), door locked	Latch locked	1 minute
1d22	Runaway temp (950° F), door locked	Latch locked	1 minute
3d11	Sensor open (single cavity or upper cavity)	Cook or clean active	20 seconds
3d12	Sensor open (lower cavity)	Cook or clean active	20 seconds
3d21	Sensor shorted	Cook or clean active	20 seconds
3d22	Sensor shorted (lower cavity)	Cook or clean active	20 seconds
9d11	Latch will not lock	Latch should be locked	See Note <sup>6</sup>
9d12	Latch will not lock (lower cavity)	Latch should be locked	See Note <sup>6</sup>
9d21	Latch will not unlock	Latch should be unlocked	See Note <sup>6</sup>
9d22	Latch will not unlock (lower cavity)	Latch should be unlocked	See Note <sup>6</sup>
9d31	Latch state unknown, both locked and unlocked	Latch locked or when lock attempted	See Note <sup>6</sup>
9d32	Latch state unknown, both locked and unlocked (lower cavity)	Latch locked or when lock attempted	See Note <sup>6</sup>
9d41	Latch state unknown, neither locked or unlocked	Latch locked/unlocked or when lock/unlock attempted	See Note <sup>6</sup>
9d42	Latch state unknown, neither locked or unlocked (lower cavity)	Latch locked/unlocked or when lock/unlock attempted	See Note <sup>6</sup>

### Diagnostic Code Handling

Code	Measurable	What is Displayed	Action Taken By Control
1c1c	Keypress	Nothing	Disables audible for affected key depression Disables all outputs <sup>1, 2</sup> Disables lights and timers
1c2c	Keyboard loop improper value	Nothing	Disables audible for key depression Disables all outputs <sup>1</sup> Disables lights and timers
1c31	Cancel key improper value	BAKE flashes <sup>3</sup>	Disables all outputs for cavity <sup>1</sup>
1c32	Cancel key improper value	BAKE flashes <sup>3</sup>	Disables all outputs for cavity <sup>1</sup>
1c6c	No response from EEPROM	Nothing	Disables all outputs <sup>1</sup>
1c7c	Calibration value out of range	"CAL" in the time digits	Completely disables oven <sup>4</sup>
1c8c	CRC invalid	Nothing	Cancels active cook functions
1d11	Sensor resistance > 2237 Ω	BAKE flashes <sup>3</sup>	Disables all cook functions for cavity
1d12	Sensor resistance > 2237 Ω (lower cavity)	BAKE flashes <sup>3</sup>	Disables all cook functions for cavity
1d21	Sensor resistance > 2787 Ω	BAKE flashes <sup>3</sup>	Disables all cook functions for cavity
1d22	Sensor resistance > 2787 Ω (lower cavity)	BAKE flashes <sup>3</sup>	Disables all cook functions for cavity
3d11	Sensor resistance > Infinite Ω	BAKE flashes <sup>3</sup>	Disables all cook functions for cavity
3d12	Sensor resistance > Infinite Ω	BAKE flashes <sup>3</sup>	Disables all cook functions for cavity
3d21	Sensor resistance > 0 Ω	BAKE flashes <sup>3</sup>	Disables all cook functions for cavity
3d22	Sensor resistance > 0 Ω	BAKE flashes <sup>3</sup>	Disables all cook functions for cavity
9d11	Lock switch not closed	LOCK flashes <sup>3</sup>	Disables Clean and Lockout functions <sup>4</sup>
9d12	Lock switch not closed (lower cavity)	LOCK flashes <sup>3</sup>	Disables Clean and Lockout functions <sup>4</sup>
9d21	Unlock switch not closed	LOCK flashes <sup>3</sup>	Disables Clean and Lockout functions <sup>4</sup>
9d22	Unlock switch not closed (lower cavity)	LOCK flashes <sup>3</sup>	Disables Clean and Lockout functions <sup>4</sup>
9d31	Latch both locked and unlocked	LOCK flashes <sup>3</sup>	Disables Clean and Lockout functions <sup>4</sup>
9d32	Latch both locked and unlocked (lower cavity)	LOCK flashes <sup>3</sup>	Disables Clean and Lockout functions <sup>4</sup>
9d41	Latch neither locked or unlocked	LOCK flashes <sup>3</sup>	Disables Clean and Lockout functions <sup>4</sup>
9d42	Latch neither locked or unlocked (lower cavity)	LOCK flashes <sup>3</sup>	Disables Clean and Lockout functions <sup>4</sup>

# Control Testing Procedures



## WARNING

To avoid risk of electrical shock, personal injury or death; disconnect power and gas to range before servicing, unless testing requires power and/or gas.

### NOTES:

- 1 "Action Taken" applies as long as the condition exists. If the condition goes away, the control recovers.
- 2 If there is a cook function or timer active, the function continues. The user cannot edit the function, and [Cancel] will cancel the cook mode.
- 3 Flash rate: 0.2 seconds on, 0.1 second off. Pressing any key will clear the display until the fault clears and is re-triggered.
- 4 "Action Taken" applies until there is a POR (Power On Reset ["hard reset"]).
- 5 If the control believes the door is locked, it will attempt to unlock it when the function cancels and the cavity temperature cools.
- 6 Special conditions for latch faults (9dxx):
  - A known good **unlock** position is defined as when the unlock switch reads closed and lock switch reads open.
  - A known good **lock** position is defined as when the unlock switch reads open and lock switch reads closed.
  - A **faulted switch** means the switch input is reading an invalid state, both/neither open and/or closed.
  - Once a latch fault occurs, latch movement is disabled until there is a POR. An error tone will sound if a function requiring a faulted latch is attempted.
  - If at POR, the latch is not at a known good unlock position:
    - If the latch is at a good lock position, it will attempt to unlock when the RTD (Resistance Temperature Device) temperature is below 400° F.
    - If the latch is not at a good lock position, the control will fault.
  - If a latch fault occurs while the RTD is above the lock temperature, the latch will not try to move, but the fault is still logged to EEPROM after the first stage of detection.
  - The Display column for latch faults applies 1) If the latch was moving when the fault occurred; 2) If the latch is already in a known locked state when the fault occurs.
    - LOCK flashes after a fault is detected and until the unlocked position is achieved. The unlock position may be identified by a successful unlock switch closure, or as the result of timing when the unlock switch is not functioning properly.
  - If the last known good position was unlock (e.g. baking, or idle) and a latch fault occurs, the motor is never moved. The fault is logged to EEPROM and is not seen by the user.
  - Latch fault detection is in two stages. The first stage is to allow the control to recover without moving the latch. After this:
    - If the latch was previously at a known good unlock position, the latch will not move and the control will fault.
    - If the control was previously in a known good lock position:
      - If the RTD is below 400°F, the latch will attempt to recover to the proper position (up to three revolutions). If it cannot, the control will fault and the latch will move to a calculated unlock position.
      - If the RTD is at or above 400° F, the control will fault. When the RTD cools to below 400° F, the control will attempt to recover to a good unlock position (up to three revolutions). If it cannot, the control will fault and the latch will move to a calculated unlock position.
      - **NOTE:** If the unlock position cannot be found, this may result in a second fault, the first fault occurring when the latch request was locked, and the second when the latch request is unlocked.
    - If the latch is moving when the fault occurs, the control will bypass the first stage of detection and immediately try to find it's proper position. If it cannot, the control will fault and the latch will move to a calculated unlock position.
  - Affected DLBs (Double Line Breaks) and loads are disabled during detection.
  - If the control is in a known good unlock position and the lock switch becomes faulted:
    - The control will not fault.
    - If a function requiring latch movement is attempted while the lock switch is faulted, the control will sound an error tone and the function will be disabled.
  - If the control is in a known good lock position and the unlock switch becomes faulted:
    - The control will not fault.
    - After the function is canceled and unlock is attempted, the control will attempt to unlock the latch according to the procedures in these notes.

# Wiring Diagram and Schematic



## WARNING

To avoid risk of electrical shock, personal injury or death; disconnect power and gas to range before servicing, unless testing requires power and/or gas.

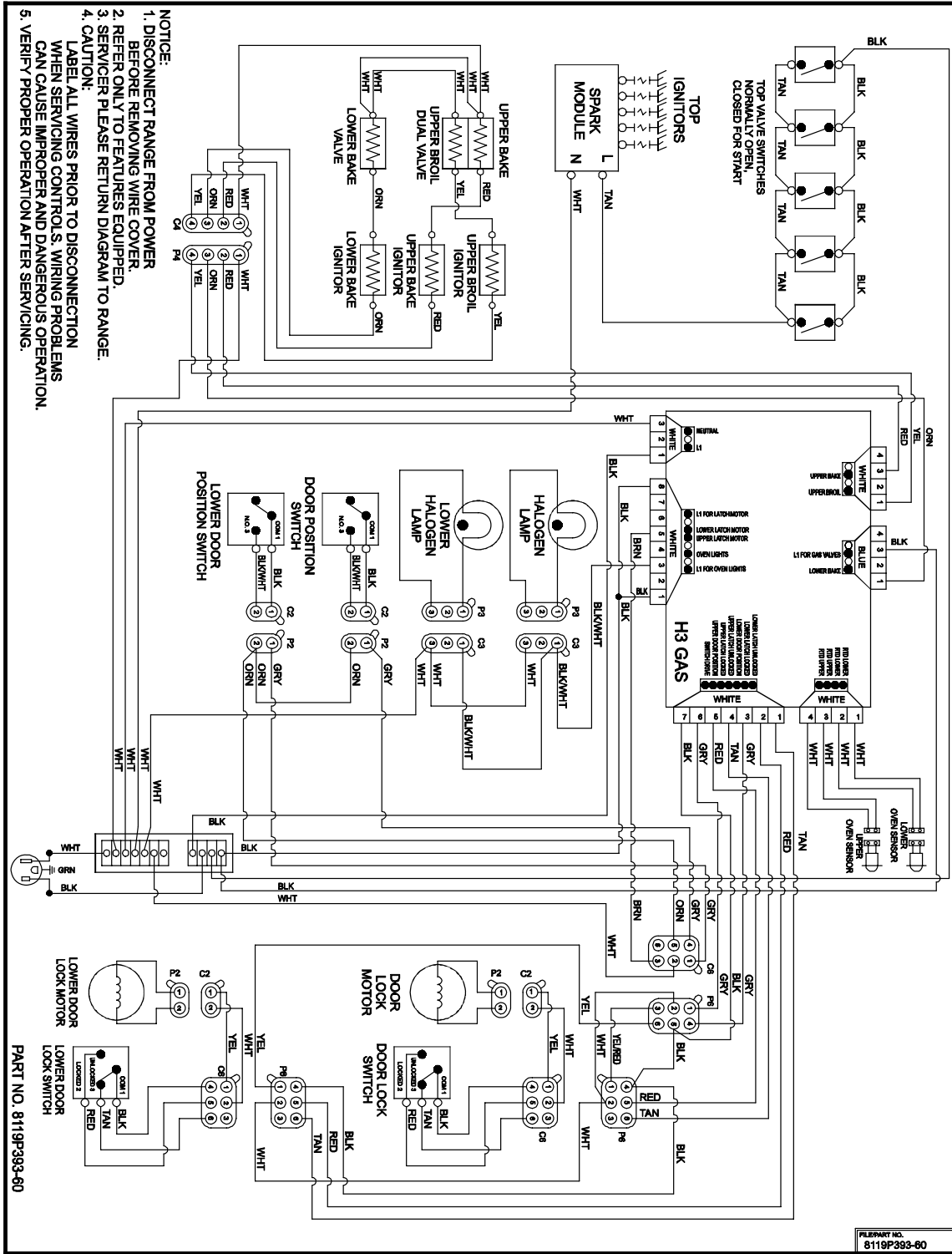

Wiring Diagram

# Wiring Diagram and Schematic



## WARNING

To avoid risk of electrical shock, personal injury or death; disconnect power and gas to range before servicing, unless testing requires power and/or gas.

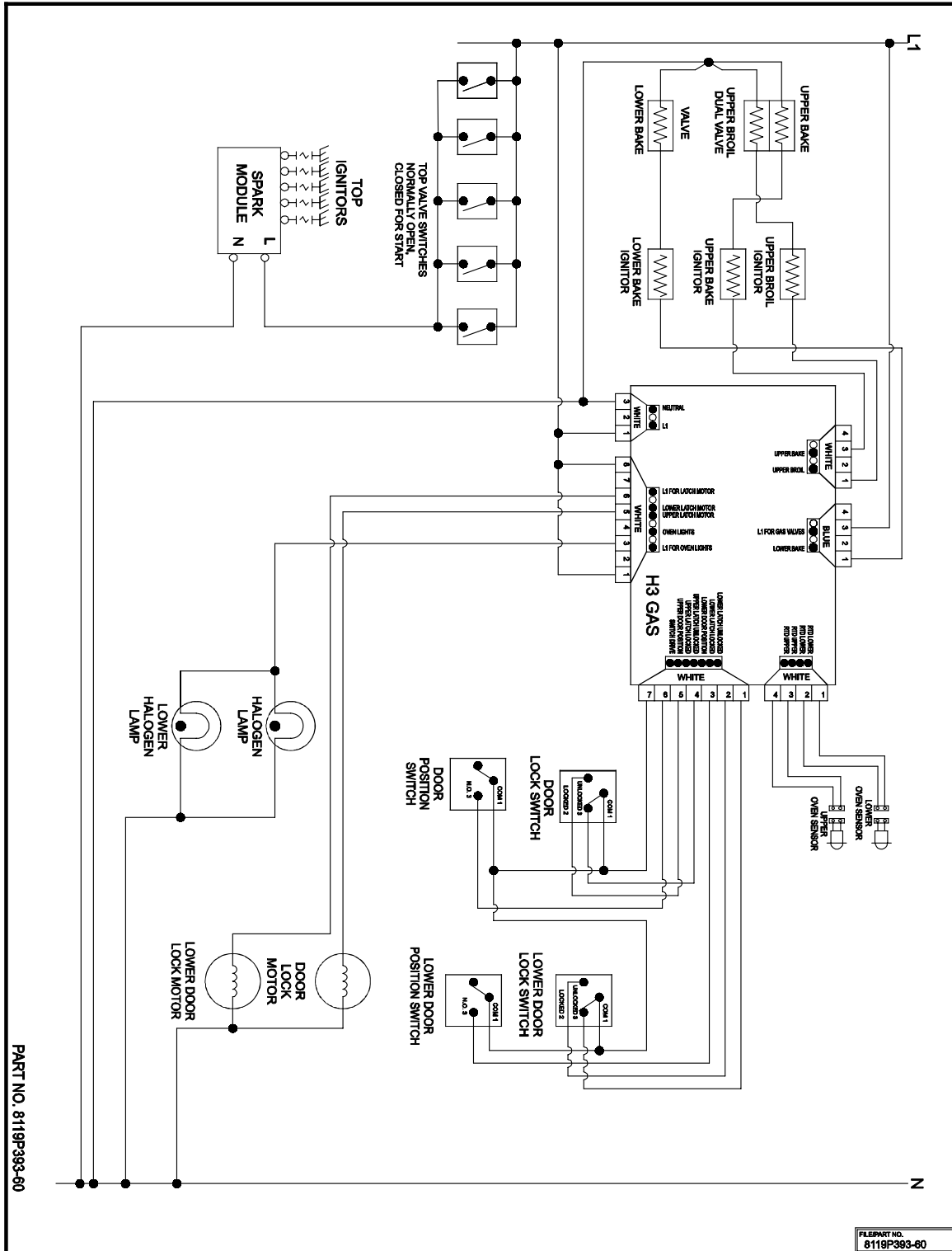

Schematic (Control Circuits)