

# SERVICE AND WIRING SHEET

19-Jul-2005 14:54:53

2225759 B



## ⚠ WARNING

**Electrical Shock Hazard**  
**Disconnect power before servicing.**  
**Replace all parts and panels before operating.**  
**Failure to do so can result in death or electrical shock.**

• Normal operating conditions are viewed when the air and temperature controls are at mid-setting, freezer section 0° to -5°F, and unit is cycling.

NOTE: Wait and pressure readings will vary and are influenced by the existing condition of the appliance, such as iced-up evaporator, condition of condenser, defrost cycle, pull-down time and customer use.

PERFORMANCE DATA *( NORMAL OPERATING CONDITIONS )			
AMB	WATTS	SYSTEM PRESSURE ( PSIG )	
		HIGH SIDE	LOW SIDE
70°	120±20	120 ± 20	-6" TO 3#
90°	130±20	160 ± 20	-4" TO 3#
110°	140±20	220 ± 20	-2" TO 4#

### SERVICE INFORMATION ( 2225754 A )

1. COMPRESSOR SUCTION AND PROCESS STUBS MAY NOT BE INTERCHANGED UNLESS INDICATED BY \*\*.
2. REFRIGERANT CHARGE MUST BE APPLIED TO HIGH SIDE ONLY.
3. ICE MAKER AND WATER VALVE NOT ORIGINAL EQUIPMENT ON ALL MODELS.
4. **CAUTION:** ICE MAKER CYCLE **MUST** BE INITIATED ELECTRICALLY. DO NOT TRY TO MANUALLY START CYCLE.
5. SERVICE DEFROST BI-METALS 50°F OPEN.
6. DEFROST TIMER MAY CONTAIN A CAPACITOR IN SERIES WITH MOTOR. DO NOT CONTINUITY TEST WHEN CHECKING FOR FAILED TIMER MOTOR. INSTEAD, ENERGIZE TIMER AND LISTEN FOR GEAR MOVEMENT.
7. THE PART NUMBER CAN BE FOUND ON THE COMPONENT. USE A REPLACEMENT PART OF SIMILAR PERFORMANCE.

### GENERAL COMPONENT INFORMATION FOR ALL REFRIGERATOR/FREEZER MODELS BE SURE TO USE CORRECT REPLACEMENT PARTS

COMPONENT (IF APPLICABLE)	EMBRACO				MATSUSHITA		WATTS • 120V	OHMS RESISTANCE
	EMY 60	EGY 60	EGY 70	EGZ 70	ESS51C	DG51		
COMPRESSOR	2225647	2216049	2216050	2221795	2225568	2217634		
RELAY-STARTING, EMB	2258450	-	-	-	-	-		
OVERLOAD PROTECTOR-T.I.I.	2149959	-	-	-	-	-		
COVER-TERMINAL	2162358	-	-	-	-	-		
RUN WINDINGS	-	-	-	-	-	-	-	1-6
START WINDINGS	-	-	-	-	-	-	-	3-11
COMPRESSOR ELECTRICAL	-	2212963	2212964	2255968	2218853	2218853	-	
RUN CAPACITOR	-	2169373	2169373	2169373	2169373	2169373	-	-
DEFROST MECH TIMER	NOTE #7	NOTE #7	NOTE #7	NOTE #7	NOTE #7	NOTE #7	-	-
ADAPTIVE DEFROST - Optional	NOTE #7	NOTE #7	NOTE #7	NOTE #7	NOTE #7	NOTE #7		
ADC/FILTER INDICATOR - Optional	NOTE #7	NOTE #7	NOTE #7	NOTE #7	NOTE #7	NOTE #7		
DEFROST HEATER	NOTE #7	NOTE #7	NOTE #7	NOTE #7	NOTE #7	NOTE #7	350-450	42-31
DEFROST BI-METAL	NOTE #7	NOTE #7	NOTE #7	NOTE #7	NOTE #7	NOTE #7	-	-
EVAPORATOR FAN	NOTE #7	NOTE #7	NOTE #7	NOTE #7	NOTE #7	NOTE #7	4-7	-
CONDENSER FAN	NOTE #7	NOTE #7	NOTE #7	NOTE #7	NOTE #7	NOTE #7	2-13	-

#### STEPS TO ENTER ELECTRONIC DEFROST CONTROL TEST MODE (IF APPLICABLE)

- OPTION #1 STEPS ( BI-METAL CLOSED )
- #1 - POWER OFF TO REFRIGERATOR FOR AT LEAST 30 SECONDS
  - #2 - THERMOSTAT OFF
  - #3 - POWER ON TO REFRIGERATOR

- OPTION #2 STEPS ( BI-METAL CLOSED ):
- #1 - THERMOSTAT OFF 15 SECONDS
  - #2 - THERMOSTAT ON 5 SECONDS  
( REPEAT STEPS 1 AND 2 TWO MORE TIMES )
  - #3 - THERMOSTAT OFF

#### ENTER TEST MODE

IN 3-8 SECONDS, CONTROL WILL TURN ON DEFROST HEATER. DEFROST HEATER WILL TURN ON FOR 18 MINUTES OR UNTIL BI-METAL OPENS. TO TERMINATE TEST EARLY, REMOVE POWER FROM REFRIGERATOR.

NOTE: IF OPTION #2 DOES NOT WORK, TRY OPTION #1 BEFORE REPLACING CONTROL. ALWAYS CHECK CONNECTIONS BEFORE REPLACING CONTROL.  
 HELPFUL HINT: UPON ENTERING TEST MODE, A RELAY TURNS OFF THE COMPRESSOR AND TURNS ON THE DEFROST HEATER. LISTEN FOR THE RELAY TO CLICK. IF RELAY CLICKS ONCE UPON ENTERING TEST MODE, CHECK FOR DEFROST HEAT. IF RELAY CLICKS TWICE ( ALLOW UP TO 30 SEC BETWEEN CLICKS ), CHECK FOR BI-METAL OPEN.



IF BI-METAL IS BY-PASSED FOR TESTING ( IF APPLICABLE ), DO NOT OVERHEAT EVAPORATOR AREA.

### COMPRESSOR OPTIONS - REFER TO APPLICABLE DESIGN

(OIL COOLER NOT PRESENT ON ALL COMPRESSORS)

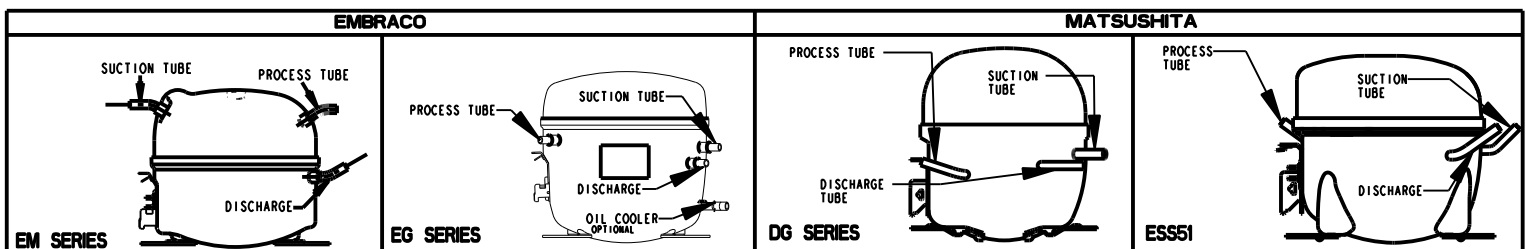

SERVICE AND WIRING SHEET NO.

2225759 B

SERVICE AND WIRING SHEET NO.

2225759 B

SERVICE AND WIRING SHEET NO.

2225759 B

SERVICE AND WIRING SHEET NO.

2225759 B

- NOTES:
1. GROUND COMPRESSOR THROUGH CONDENSER.
  2. IM SOLENOID VALVE GROUNDED THROUGH MOUNTING.
  3. EVAP COVER GROUNDED THROUGH HEAT SHIELD.



## WARNING

**Electrical Shock Hazard**  
**Disconnect power before servicing.**  
**Replace all panels before operating.**  
**Failure to do so can result in death or electrical shock.**

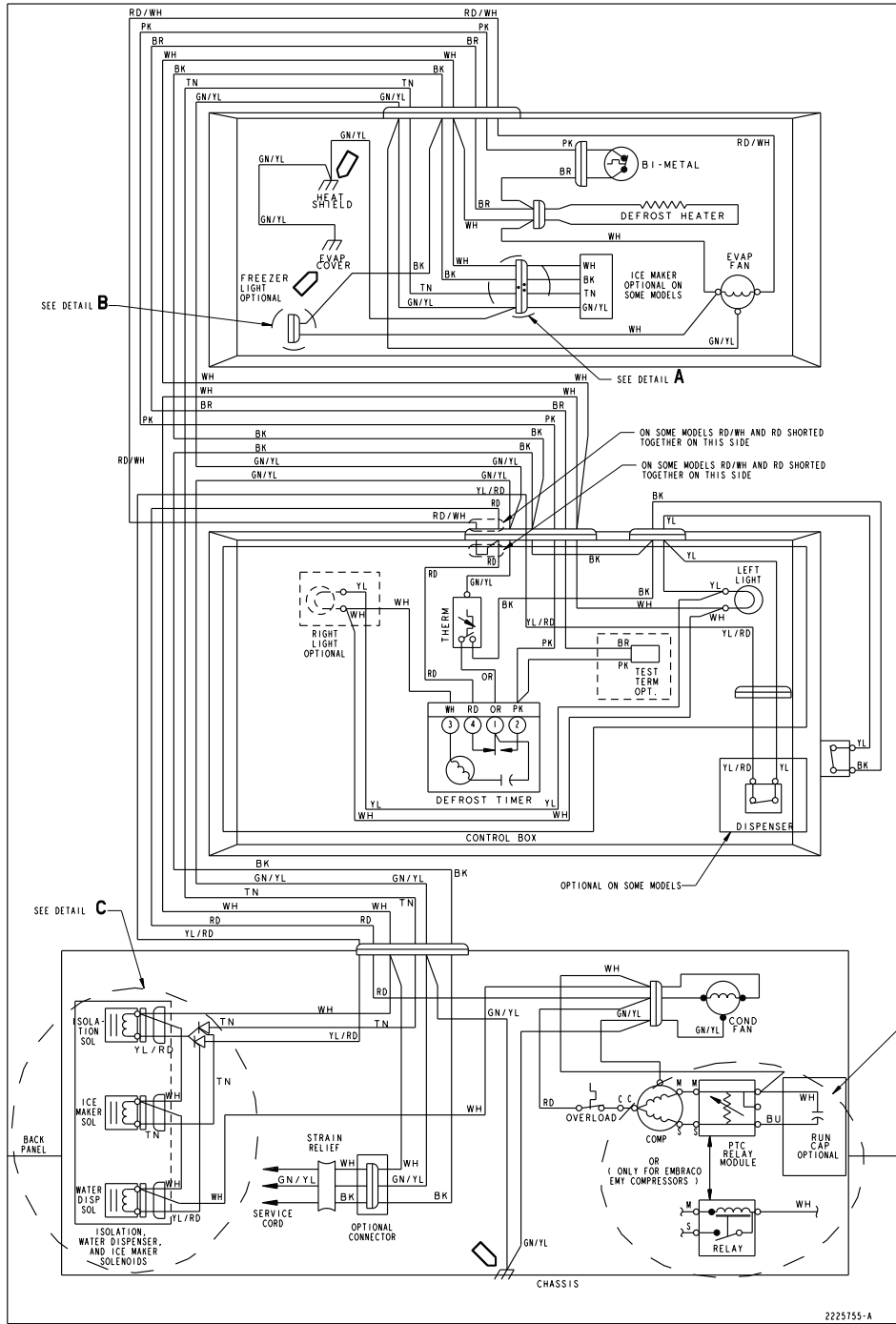

NOTE: 1M SOLENOID VALVE GROUNDED THROUGH MOUNTING

### WIRING DIAGRAM

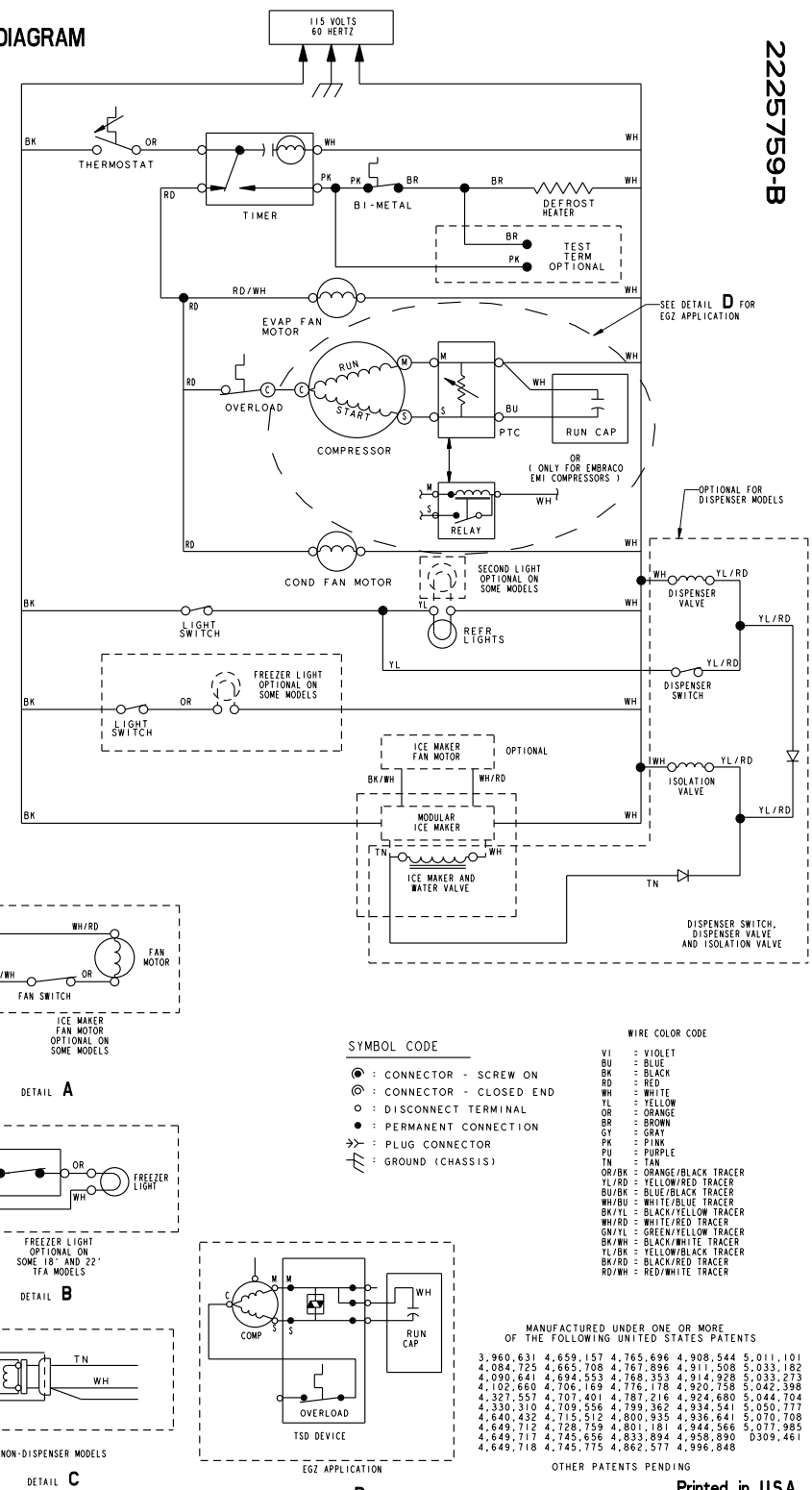

2225759-B

SERVICE & WIRING SHEET NO. 2225759-B