

# 234D2437P033 Rev 18

## SERVICE PARTS AND LUBRICATION

Motor . . . . .	120V-60HZ (WE17X23056)
Drive Belt . . . . .	WE12M29
Idler Pulley . . . . .	WE12M8
Drum Bearing Sleeve . . . . .	WE1M462
Grease - Idler Bearing . . . . .	WE25X46

**SERVICE NOTE:** Some replacement parts may have more terminal connections than the original part. Wire the new part to the same numbered terminals as the original part and disregard the unused terminals unless a special instruction is provided.

### AIR FLOW AND SEALS

Proper air flow through the dryer is essential for normal operation of the temperature control and safety systems. Air is PULLED into the cabinet from rear and drawn up across the heaters located behind the drum. This hot air is PULLED through the drum rear, across the clothes load, through the lint trap and down the trap duct into the blower. From the blower the air is PUSHED out of the exhaust system. Any air leaks between the air inlet and the blower, such as lower drum front left or trap duct to cabinet front sealing, will result in improper temperatures. The air being pulled down the trap duct to the drum outlet thermostat will be cooler than normal, giving this thermostat a false indication (delayed or no-trip). Leaks ahead of the blower will also reduce the volume of air across the heaters causing hot spots and possible premature failure.

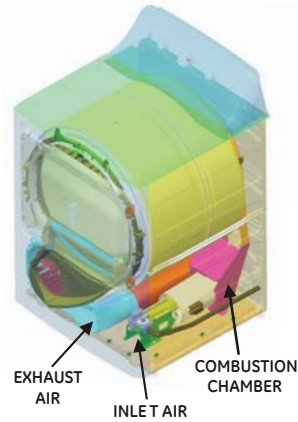

### TRAP DUCT SEALING

To inspect the trap duct for proper sealing, remove the lint filter and look down into the duct. With a light examine the trap duct on all sides where it meets the dryer front for voids in sealing. Leaks may be sealed with permagum.

- WHEN FLEXIBLE DUCT IS USED, WE STRONGLY RECOMMEND METALLIC FLEXIBLE DUCT.
- EXHAUST DUCT MUST BE 100mm (4 INCH) DIAMETER
- FOR SPECIFIC EXHAUST SPECIFICATION, REFER TO INSTALLATION INSTRUCTIONS SUPPLIED WITH DRYER.

### DRIVE BELT

The drum is rotated counterclockwise, as viewed from the front, at a speed of 47-51 RPM. Belt tension is maintained by a spring-loaded idler pulley and driven by a pulley attached to the rear motor shaft.

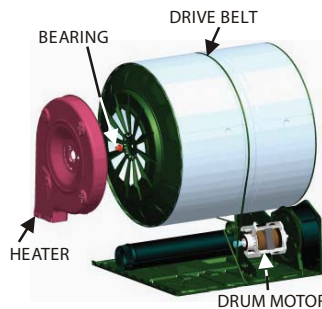

### STEAM SYSTEM (on some models)

Water is injected in the drum through a nozzle located at the front of the appliance. A water valve located at the bottom rear of the dryer provides water to nozzle. When servicing nozzle check for leaks and replace if necessary.

**IMPORTANT** - Reconnect the steam supply hose coupling on models so equipped.

GE is a trademark of the General Electric Company. Manufactured under trademark license.

## DISASSEMBLY

**Step 1:** Remove the two hex head screws from the top rear corners of the control panel.

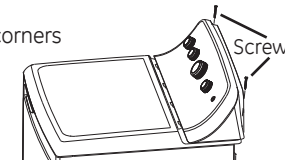

**Step 2:** Grasp the control panel sides, push it back, and roll it up and off. Carefully lay it on its face on the top cover.

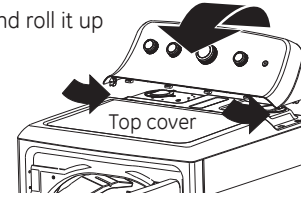

**Step 3:** Remove the five screws from the control panel cover.

Disconnect the connectors from the control board and set the control panel aside

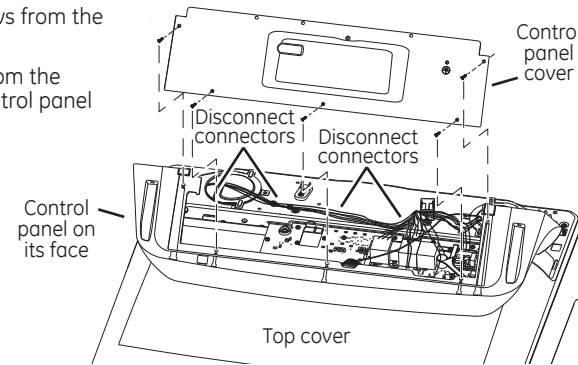

**Step 4:** Remove the screws/rear cover plates from the top cover.

Remove the ground wire screw from the back right corner opening.

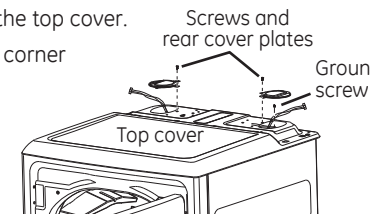

**Step 5:** Remove the two phillips head screws from the back corners of the top cover.

Open the dryer door and remove the two screws from the front underside of the top cover.

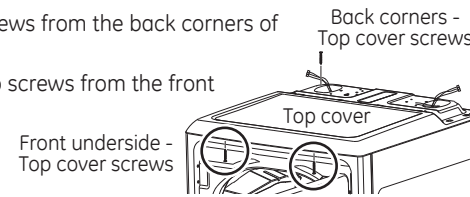

**Step 6:** Grasp the front corners of the top cover, lift up, slide back and lift up. Hold the top cover with one hand, push the wiring harnesses through the openings and then set the top cover aside.

**NOTE:** To remove the front panel, remove the two screws from the top front panel corners, and disconnect all of the connectors and the water line. Set the front panel aside.

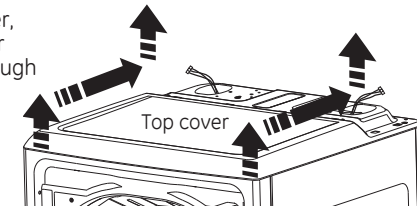

## NOTES:

**NOTE 1** Other factors contributing to long dry times, or clothes condition: load size, large bulky items, ambient temperature, room size (if not exhausted outdoor), washer spin speed, washer rinse temperature, gas supply (restrictions), gas pressure.

**NOTE 2** Small loads: Less than 3 lbs. if not treated with destaticizer could develop a static charge if over dried and cling to drum surface (no tumble) causing wrinkles, shrinkage, or melting. Use a fabric softener (washer or dryer) or add 2 large bath towels to act as a buffer when drying.

31-16924 01-17 GEA  
234D2437P033 Rev 18



**⚠ WARNING** **Explosion Hazard**

Death or serious injury can result from failure to follow these instructions.

- Service by a qualified service technician only.
- Shut off gas supply and disconnect power before servicing.
- Reconnect all grounding devices after service.
- Replace all parts and panels before operating.

**⚠ AVERTISSEMENT** **Risque d'explosion**

Des blessures graves ou fatales peuvent résulter du défaut d'observer ces instructions.

- Réparations seulement par un technicien qualifié.
- Fermez l'alimentation en gaz et débranchez l'alimentation électrique avant la réparation.
- Rebranchez tous les dispositifs de mise à la terre après la réparation.
- Remettez toutes les pièces et panneaux en place avant d'utiliser l'appareil.

**⚠ ADVERTENCIA** **Riesgo de explosión**

Si no se siguen estas instrucciones, se puede producir la muerte o lesiones graves.

- El servicio técnico sólo debe ser realizado por un técnico calificado.
- Cierre el suministro de gas y desconecte el suministro de corriente antes de realizar el servicio técnico.
- Luego del servicio técnico, vuelva a conectar todos los dispositivos de conexión a tierra.
- Reemplace todas las piezas y paneles antes de utilizar.

**DANGER:** DISCONNECT ELECTRIC POWER SUPPLY BEFORE SERVICING  
**CAUTION:** LABEL ALL WIRES PRIOR TO DISCONNECTION. WHEN SERVICING CONTROLS, WIRING ERRORS CAN CAUSE IMPROPER AND DANGEROUS OPERATION. VERIFY PROPER OPERATION AFTER SERVICING.

SCHEMATIC:

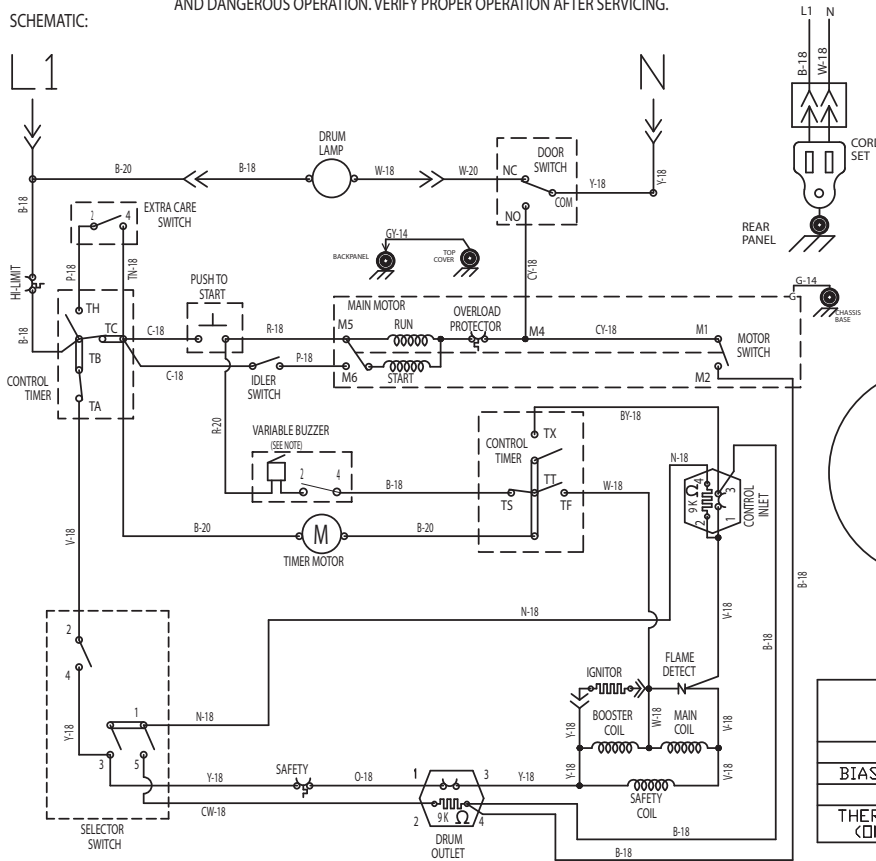

NOTE:  
 EOC SIGNAL WILL SOUND WHEN TIMER IS IN COOL DOWN PERIOD OF CYCLE AND DURING EXTRA CARE CYCLE. IT OPERATES WITH SIGNAL ON 5 SECONDS AND OFF 70 SECONDS. TO TEST - SET TIMER NEAR END OF CYCLE OR IN EXTRA CARE CYCLE AND WAIT 2 MINUTES FOR SIGNAL TO SOUND. TIMER MUST BE ALLOWED TO RUN, AND ELECTRICALLY ENERGIZE SIGNAL.

TERMINAL LEGEND  
 T = TIMER  
 M = DRIVE MOTOR

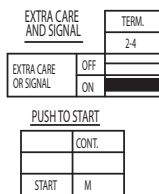
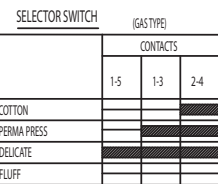
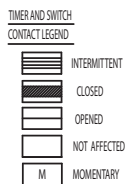

**WINDINGS & COILS RESISTANCE VALUES**

MAIN MOTOR	START	2.98-3.30 Ω
	RUN	3.19-3.53 Ω
	MAIN	1300 Ω
GAS VALVE	BOOSTER	580 Ω
	SAFETY	1400 Ω
	IGNITOR	-
TIMER MOTOR	-	3384-3816 Ω

**Gas Dryer**

4 CYCLES CONTROL TIMER CAM CHART

360° = 270 MIN.	OFF	AUTO PERMA PRESS POLY-KNITS	X. CARE	OFF	AUTO DELICATES	X. CARE	OFF	NORMAL TIMED CYCLE	OFF	AUTO COTTON CYCLE	X. CARE
								70 60 50 40 30 20 10			
A-B (HEATER)											
B-H (MOTOR)											
B-C (MOTOR)											
T-X (TIMER)											
T-F (TIMER)											
T-S (SIGNAL)											

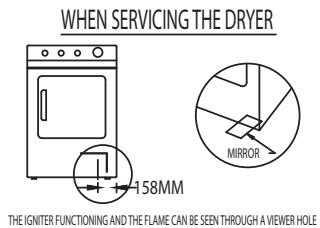
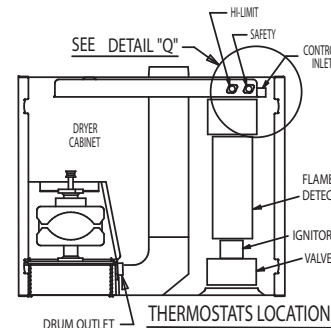
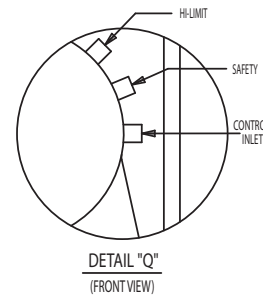
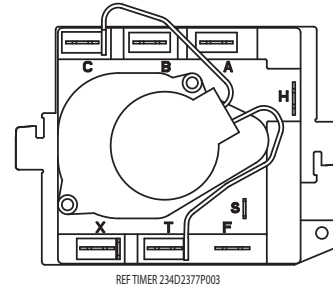

THERMOSTAT	TEMPERATURE °F		TEMPERATURE °C		CAPACITY CuFt	
	OPEN	CLOSE	OPEN	CLOSE	6.2	7.2
DRUM OUTLET	135 ± 5	125 ± 6	57 ± 3	52 ± 3	X	X
BIASED CONTROL INLET	205 ± 5	175 ± 6	96 ± 3	80 ± 3	X	X
SAFETY LEFT	305 ± 8	265 ± 12	152 ± 5	131 ± 7	X	X
THERMO HI-LIMIT RIGHT (ONE SHOT DEVICE)	365 ± 8	- - -	185 ± 5	- - -	X	X

XX-YY WIRE COLOR  
 YY-WIRE GAUGE  
 B: BLACK  
 BY: BLACK/YELLOW  
 C: BROWN  
 CY: BROWN/YELLOW  
 CW: BROWN/WHITE  
 G: GREEN  
 GY: GREEN/YELLOW  
 N: NAVY BLUE  
 R: RED  
 O: ORANGE  
 OB: ORANGE/BLACK  
 P: PINK  
 S: GRAY  
 V: PURPLE  
 W: WHITE  
 Y: YELLOW  
 TN: TANGERINE