



GE APPLIANCES
a Haier company

Technical Service Guide

June 2021

2020 Plastic Tub Dishwasher

GDF510P*M5**

GDF511P*M5**

GDF530P*M5**

GDF630P*M5**

GDF640H*M5**

GDP615H*M5**

GDP615H*N5**

GDT530P*P1**

GDT530P*P5**

GDT540P*P5**

GDT535P*M5**

GDT540P*M5**

GDT605P*M5**

GDT630P*M5**

GDT635H*M1**

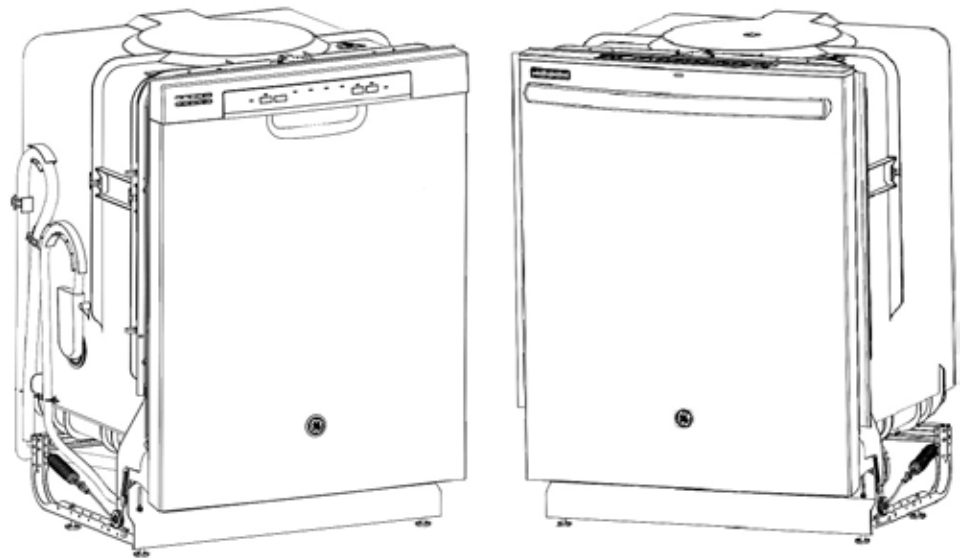

XDF300P*N5**

XDF400P*N5**

XDT500P*P5**

Safety Information



IMPORTANT SAFETY NOTICE

The information in this service guide is intended for use by individuals possessing adequate backgrounds of electrical, electronic, and mechanical experience. Any attempt to repair a major appliance may result in personal injury and property damage. The manufacturer or seller cannot be responsible for the interpretation of this information, nor can it assume any liability in connection with its use.

WARNING

To avoid personal injury, disconnect power before servicing this product. If electrical power is required for diagnosis or test purposes, disconnect the power immediately after performing the necessary checks.

RECONNECT ALL GROUNDING DEVICES

If grounding wires, screws, straps, clips, nuts, or washers used to complete a path to ground are removed for service, they must be returned to their original position and properly fastened.

Warranty

For Warranty Information:

1. Go to <http://products.geappliances.com>
2. Search the model number.
3. Click on the Literature tab.
4. Click on Use and Care Manual.
5. Locate the Warranty page.

GE Appliances, a Haier Company

Copyright © 2021

All rights reserved. This service guide may not be reproduced in whole or in part in any form without written permission from GE Appliances, a Haier Company.

Table of Contents

Safety Information	2
Warranty	2
Table of Contents	3
Safety Requirements	6
Nomenclature	7
Specifications	8
Product Specifications	8
Electrical Specifications	8
Operation and Cycle Information	9
Troubleshooting	12
Flashing Lights	12
Will Not Start	12
Component Locator Views	13
Front Control	13
Top Control	13
Toe Kick Area	14
Side	14
Back	15
Bottom	15
Sump (Top)	16
Sump (Bottom)	16
Inside	17
Racks	18
Tub and Structure	19
Tub Trim (Some Models)	19
Toe Kick	19
Junction Box and House Wiring Connection	19
Leveling Legs	20
Door Balance System	20
Hinge	21

Tub Gasket	21
Latch System	22
Tub Latch Switch Diagnosis	23
Racks.....	23
Door.....	27
Inner Door Vent Cover.....	29
Front Control Console	30
User Interface (UI)	30
Front Control UI, Light Pipe and Buttons.....	31
Pocket Handle (Front Control Only)	32
Pocket Handle (GDP615).....	32
Fan Assist Dry (On Some Models)	33
Top Control Panel, UI, Light Pipe and Buttons	33
Top Control Console Cover	34
Outer Door Panel.....	35
Inner Door Panel	35
Door Gasket	36
Vent Parts (On Some Models).....	36
Detergent Dispenser.....	36
Door Strike.....	37
Sump Module	38
Sump Gasket.....	42
Installing Sump Module	42
Electronic Controls	43
Error Mode.....	43
Fault Codes	44
Critical Faults.....	46
Service Mode.....	47
Diagnosing Electronic Control Boards.....	47
Main Control Diagnostics.....	47
On the Main Control Board CSM.....	48
User Interface (UI) Diagnostics	50

(Continued next page)

Fill System.....	51
Water Level.....	51
Pressure Sensor.....	51
No Fill Diagnostics.....	53
Fill Funnel and Hose.....	54
Fill Valve.....	54
Circulation System.....	55
Diagnostics.....	56
No Circulation and Drain.....	57
Motors Fuse.....	57
Filtration.....	58
Circulation Motor and Pump Assembly.....	59
Two-Port Diverter.....	60
Turbidity Sensor and Thermistor.....	62
Thermistor.....	63
Main Conduit.....	64
Spray Arms.....	64
Middle Conduits.....	65
Bottle Wash System (Some Models).....	66
Upper Spray System.....	66
Drain System.....	67
Operation.....	67
Drain Pump Diagnostics.....	67
Drain Components.....	67
Failure to Drain Diagnostics.....	68
Drain Pump.....	69
Dry System.....	70
Introduction and Operation.....	70
Heater Components.....	71
Heat Element Removal.....	74
Venting / Airflow.....	75
Schematics.....	76
Index.....	78

Safety Requirements

GEA Factory Service Employees are required to use safety glasses with side shields, safety gloves and steel toe shoes for all repairs.



Plano Type Safety Glasses



Prescription Safety Glasses

Safety Glasses must be ANSI Z87.1-2003 compliant



Dyneema® Cut Resistant Glove



Cut Resistant Sleeve(s)



Electrically Rated Glove and Dyneema® Cut Resistant Glove Keeper



Steel Toed Work Boot



Prior to disassembly of the dishwasher to access components, GEA Factory Service technicians are REQUIRED to follow the Lockout / Tagout (LOTO) 6 Step Process:

Step 1 Plan and Prepare	Step 4 Apply LOTO device and lock
Step 2 Shut down the appliance	Step 5 Control (discharge) stored energy
Step 3 Isolate the appliance	Step 6 “Try It” verify that the appliance is locked out

Nomenclature

Model Number

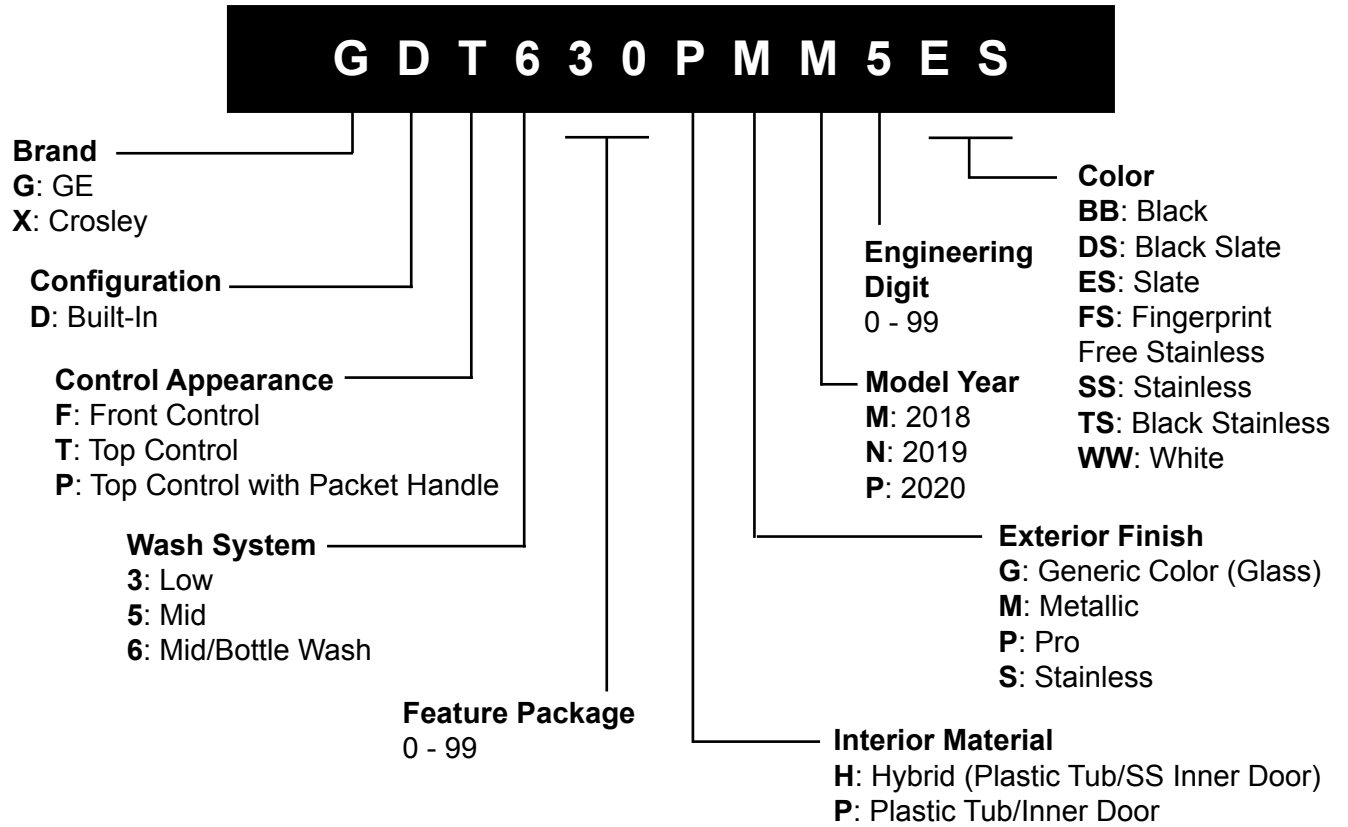

The nomenclature breaks down and explains what the letters and numbers mean in the model number.

Serial Number

The first two characters of the serial number identify the month and year of manufacture. The letter designating the year repeats every 12 years.

Example: TR123456S = October, 2020

A: JAN	2024: Z
D: FEB	2023: V
F: MAR	2022: T
G: APR	2021: S
H: MAY	2020: R
L: JUN	2019: M
M: JUL	2018: L
R: AUG	2017: H
S: SEP	2016: G
T: OCT	2015: F
V: NOV	2014: D
Z: DEC	2013: A

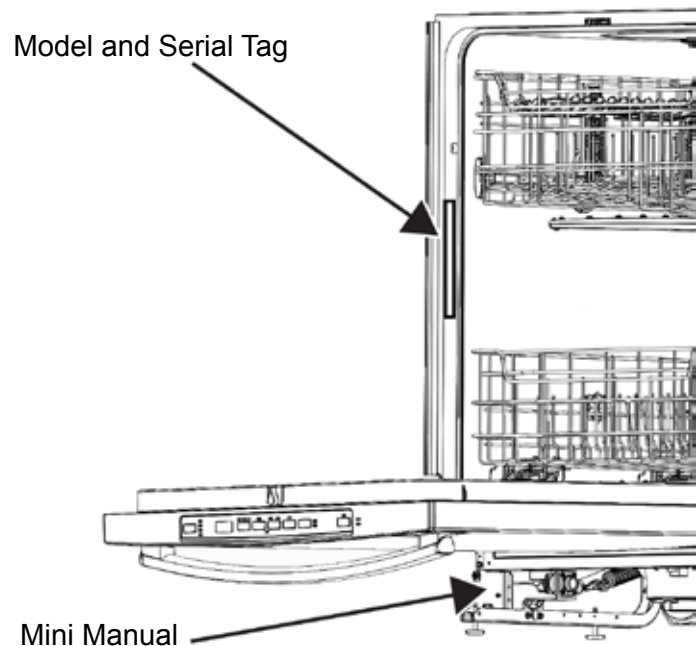

Specifications

Product Specifications

- **Approximate Shipping Weight (lb.)** ~ 70-pounds (depending on model)
- **Height w/ Legs Retracted (in.)** 33 3/8-inches
- **Height w/Legs Extended (in.)** 34 5/8-inches
- **Overall Width (in.)** 23 3/4-inches
- **Overall Depth (in.)** 24-inches

Electrical Specifications

AC Voltage

- **Circulation Pump:** 120 VAC, .8 amp to 3.8 LRA, 8 GPM @ 5 PSI
- **Drain Pump:** 120 VAC, ~40 Ω*, .65 amp, ~70 second cycle

Heater 120 VAC			
	Wet	Dry	
Watts	800	500	+/- 5%
Ohms	18	28.8	+/- 5%
Amps	6.67	4.17	+/- 5%

- **Main Control:** Input 120 VAC, Output 120 VAC, and Output 5 and 13.5 VDC

DC Voltage

- **Door Switch:** 13.5 VDC
- **Water Valve:** 13.5 VDC, 32 Ω, .83 GPM, ~1 minute cycle time
- **User Interface (UI) Control:** 13.5 VDC (some models have 13.5 VDC output to detergent module and dry fan)
- **Detergent Cup:** 13.5 VDC, 25 Ω, .5 second to release detergent cup, 15 seconds to release rinse aid
- **Fan Assist Dry** On some models, 13.5 VDC
- **Flood Switch:** 13.5 VDC, .42 amp
- **Turbidity Sensor:** 5 VDC to LED, 10K Ω

Thermistor Specifications	
Resistance	Temperature
20k	50°F
11k	75°F
5.8k	100°F
3.4k	125°F
2.1k	150°F
1.3k	175°F

Operation and Cycle Information

This section of the guide provides details on segments of cycles, timing of cycles, temperature expectations and cycling of the heater during the dry portion of a cycle.

Auto Hot Start

If incoming water temperature is below 75°F, Auto Hot Start is initiated at the beginning of the cycle in an attempt to purge the home water lines of cooler water. Auto Hot Start can add up to 10-minutes to overall cycle time. One Auto Hot Start segment includes a 1-minute fill, 1-minute circulate and 70-second drain, repeating this sequence if the 75°F temperature is not met. The dishwasher can repeat this up to three times, if needed. If the temperature is met in one or two segments, the cycle advances to the first prewash segment of the cycle.

Cycle Times

Times will vary depending on options selected, incoming water temperature, and soil level (on some models).

Incoming water temperature of 120°F through 140°F is recommended.

The cycle chart below explains the segments of a cycle (cycles for all models included, some cycles are only in select models). The chart below details fill and drain times which depend on either a full or partial drain. It provides the circulation time in each segment, but does not include dry cycles (see the **Dry System** section in this service guide). Times will vary depending on turbidity response (on some models), options selected and water temperature.

Cycle Algorithm Comparisons												
Segment	Description	Diverter Position	Zonal Use	Light	Normal			AutoSense		Heavy	1-hour/Express	
					Fixed	Light Soil	Heavy Soil	Light Soil	Heavy Soil			
PW1	Fill (gal) Circ (min) Heat Drain	30LSA/ 30USA	No		0.8 3 No No Drain	0.8 10 No Empty	0.8 7 No Empty	0.8 10 No Empty	0.8 7 No Empty	0.8 7 No Empty	0.8 4 No Empty	
PW2	Fill (gal) Circ (min) Heat Drain	LSA with pulsing	No				0.8 10 No Empty		0.8 10 No Empty	0.8 10 No Empty	0.9 4 No Empty	
PW3	Fill (gal) Circ (min) Heat Drain	60 LSA/ 60 USA	No				0.8 5 No Empty		0.8 5 No Empty	0.8 5 No Empty		
PW4	Fill (gal) Circ (min) Heat Drain	60 LSA/ 60 USA	Yes Shorten ~30%							0.8 15 Yes Empty		
Main Wash	Fill (gal) Circ (min) Heat Drain	180 LSA/ 180 USA	Yes will Shorten ~30%		0 20 Yes Empty	0.8 40 Yes Empty	0.8 40 Yes Empty	0.8 45 Yes Empty	0.8 45 Yes Empty	0.8 45 Yes Empty	0.9 17 Yes Empty	
PR1	Fill (gal) Circ (min) Heat Drain	180 LSA/ 180 USA	Yes will Shorten ~30%				0.9 12 No Empty	0.9 12 No Empty	0.9 12 No Empty	0.9 12 Yes Empty	0.9 4 No Empty	
PR2	Fill (gal) Circ (min) Heat Drain	60 LSA/ 60 USA	Yes will Shorten ~30%	0.95 4 No Empty	0.8 4 Yes Empty	0.8 4 No Empty	0.8 4 No Empty	0.8 5 No Empty	0.8 5 No Empty	0.8 4 No Empty	0.9 4 No Empty	
Final Rinse	Fill (gal) Circ (min) Heat Drain	60LSA/ 120USA	No	0.95 5 No Empty	0.8 15 Yes Empty	0.8 15 Yes Empty	0.8 15 Yes Empty	0.9 30 Yes Empty	0.9 30 Yes Empty	0.9 30 Yes Empty	0.9 9 Yes Empty	

NOTES:

- The previous chart has maximum segment parameters listed. The control will bypass some rinse cycles if the turbidity sensor detects lower soil than the selected cycle maximum parameter, and temperature targets are met.
- Selecting the Wash Temp option will add 5-minutes to Pre-Wash 4 (PR4) and Post-Rinse 1 (PW1). This extra time is used to heat water.
- The Sani/Steam option will change the segments Pre-Wash 4 (PW4), (increasing heater operation).
- The Bottle Wash option (on some models) may increase the cycle time, adding up to 23-minutes; water usage does not change.
- **USA** (Upper Spray Arm): When a number is placed before the USA, it indicates the approximate time in seconds of operation.
- **LSA** (Lower Spray Arm): When a number is placed before LSA, it indicates the approximate time in seconds of operation.
- **PW**: Pre Wash
- **PR**: Post Rinse
- **FR**: Final Rinse

Target / Max Temperature Limits				
Cycle	PW4	MW	Rinse	FR
Light		125	130	135
Normal		125		140
Auto		130	130	140
Heavy	130	130	130	145

Heater Algorithm, Dry Cycle	
Normal with Heated Dry	
Time (minutes)	Calrod Description
7	Calrod On
27	Calrod Pulse: 2-minute on/1-minute off
14	Calrod Off: Cool Down
Normal with Temp Boost or Steam/Sani Selected	
7	Calrod On
57	Calrod Pulse: 1-minute on/1-minute off
Boost Dry Option	
7	Calrod On
57	Calrod Pulse: 2-minute on/1-minute off
15	Calrod Off: Cool Down

Cycle Option Selected					Rinse	Light	Normal Sensor	Auto	Heavy	1-Hour	
All Zones	No Options				16	51	80	107	143	60	
				Boost Dry	N/A	155	184	211	247	164	
				Heated Dry		N/A	115	128	127	207	124
			Bottle Wash			N/A	74	103	130	166	83
		Temp Boost				N/A	N/A	111	129	156	N/A
	Sani-Steam					N/A	N/A	155	171	176	N/A
			Bottle Wash		Boost Dry	N/A	178	207	234	270	187
		Temp Boost			Boost Dry	N/A	N/A	215	233	260	N/A
	Sani-Steam				Boost Dry	N/A	N/A	259	275	280	N/A
			Bottle Wash	Heated Dry		N/A	138	151	150	230	147
		Temp Boost		Heated Dry		N/A	N/A	175	149	220	N/A
	Sani-Steam			Heated Dry		N/A	N/A	219	197	211	243
		Temp Boost	Bottle Wash		Boost Dry	N/A	N/A	238	256	283	N/A
	Sani-Steam		Bottle Wash		Boost Dry	N/A	N/A	282	298	303	N/A
	Sani-Steam	Temp Boost			Boost Dry	N/A	N/A	259	275	280	N/A
		Temp Boost	Bottle Wash	Heated Dry		N/A	N/A	198	172	243	N/A
	Sani-Steam		Bottle Wash	Heated Dry		N/A	N/A	242	258	263	N/A
	Sani-Steam	Temp Boost		Heated Dry		N/A	N/A	219	235	240	N/A
	Sani-Steam	Temp Boost	Bottle Wash		Boost Dry	N/A	N/A	282	298	303	N/A
	Sani-Steam	Temp Boost	Bottle Wash	Heated Dry		N/A	N/A	242	258	95	N/A

Troubleshooting

This troubleshooting section is an overview of diagnostic capabilities of the electronic control. The control also features retrieval of fault codes when Error Mode is initiated; operation of loads is achieved in Service Mode.

Details on Error Mode and Service Mode, as well as Service LED are located in the **Electronic Controls** section of this service guide.

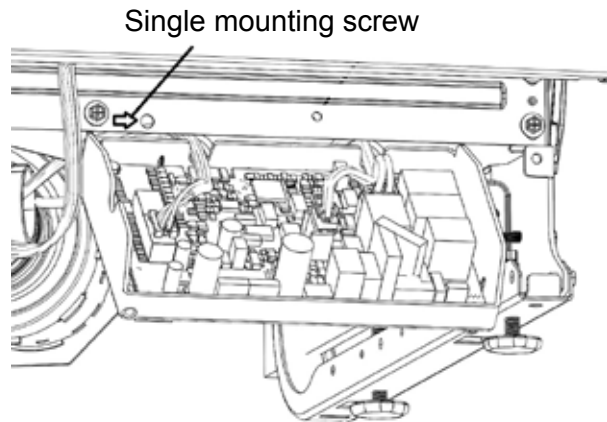

Flashing Lights

If the control beeps and some LED's flash, this indicates the dishwasher door may be in the open position. If the user interface (UI) is flashing all the LED's or the display is flashing 888 on (some models), this is an indication of a tripped CSM and the dishwasher is non-responsive, all the LED's will flash until the CSM is reset. CSM diagnostics are covered under **On the Main Control Board CSM** in the **Electronic Controls** section of this service guide.

Will Not Start

- Check voltage input to the dishwasher.
- Verify door switch operation, consult **Error Mode**, in the **Electronic Controls** section of this service guide.
- Door must be closed within 5-seconds of pressing Start Pad (Safety Feature).
- Check the main board Service LED (see **Main Control Diagnostics** in **Electronic Controls**).
- Verify that the dishwasher is not in **Demo Mode**.
- CSM (Current Sense Module) tripped. Please refer to **On the Main Control Board CSM** in the **Electronic Controls** section of this guide.

Symptom: If the dishwasher is “dead”, no LED operation, no button operation or beeping occurs.

Diagnosis: Attempt placing the dishwasher in Error Mode.

Solution: The CSM (Current Sense Module) is tripped and must be fully diagnosed. Refer to **On the Main Control Board CSM** section of this guide.

Symptom: If the start button *either* does not respond or it makes a triple beep sound *every time it's pressed* **AND** all other buttons respond as normal.

Diagnosis: The dishwasher may be in Demo Mode.

Solution: To exit Demo Mode, hold “SELECT CYCLE” and “HEATED DRY” at the same time for 5-seconds.

Component Locator Views

Appearances may vary throughout this service guide. Some models do not have all features shown or may be different depending on the model number.

Front Control

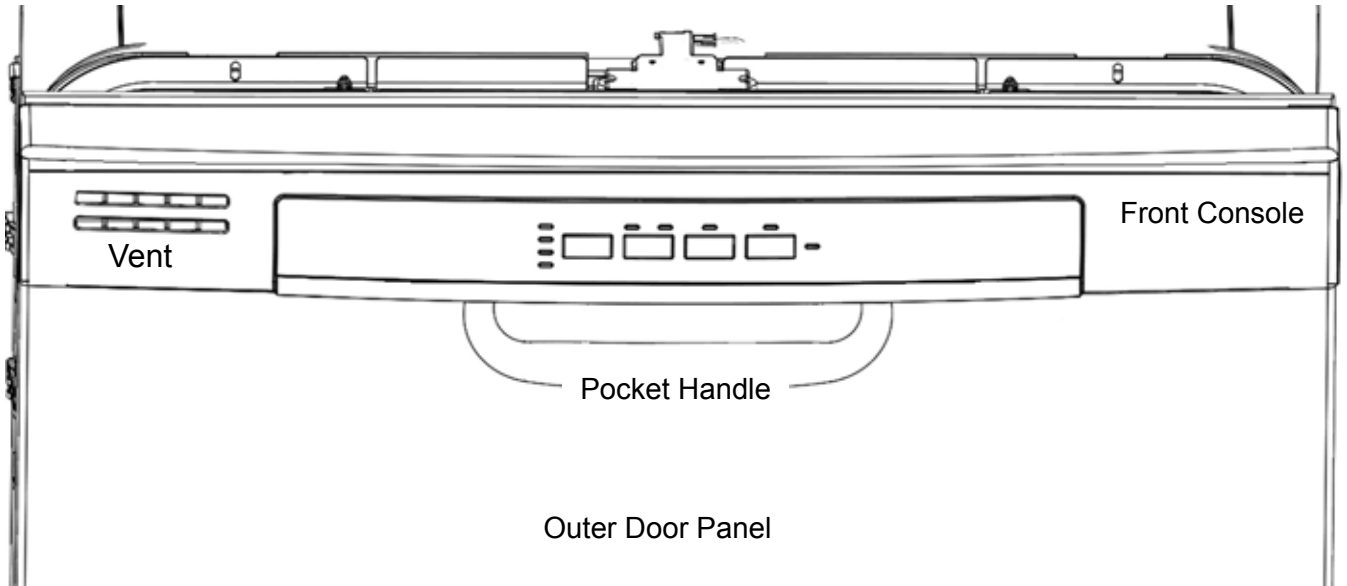

Top Control

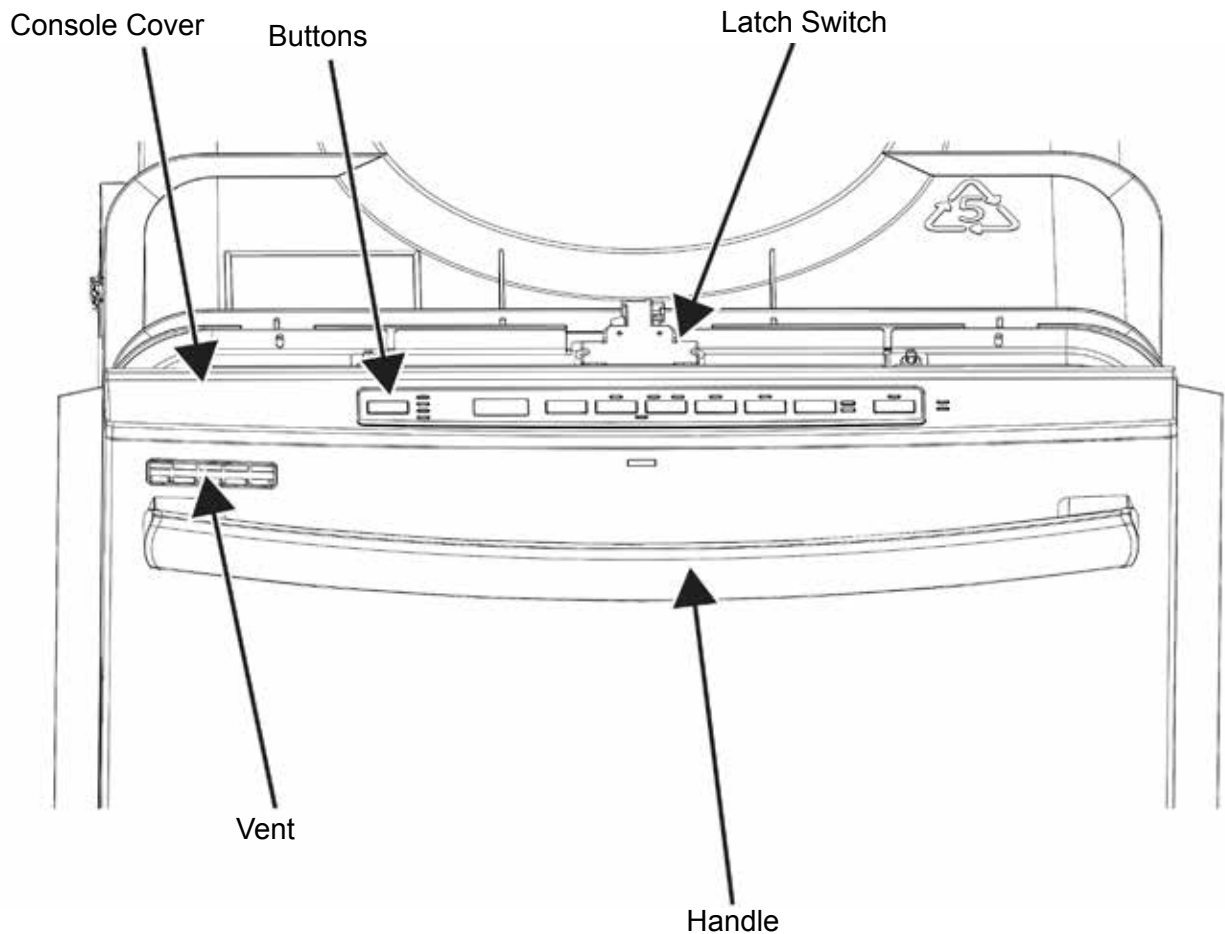

Toe Kick Area

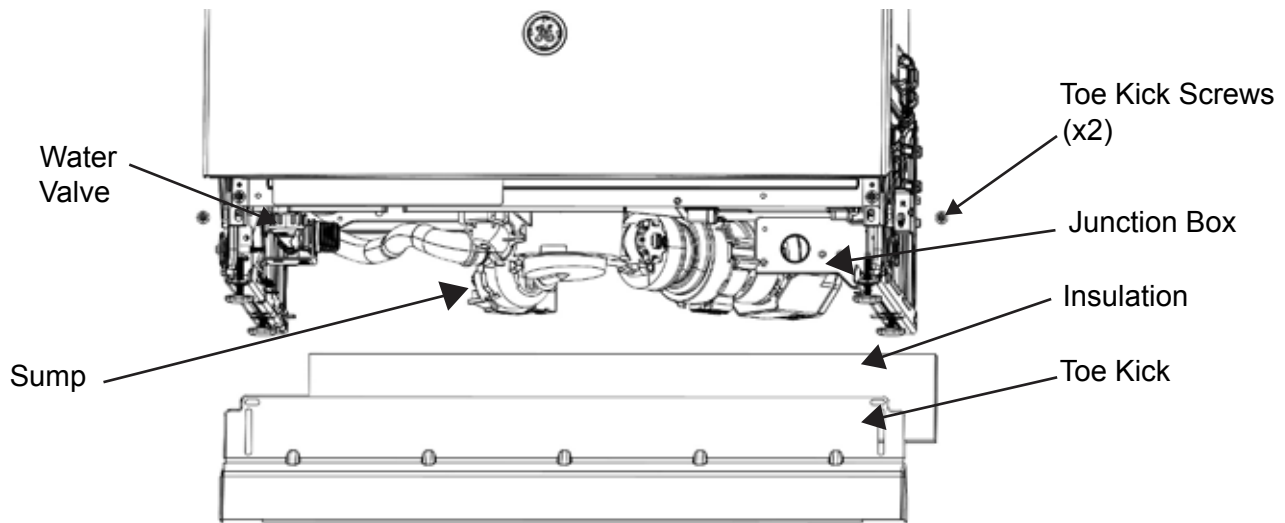

Side

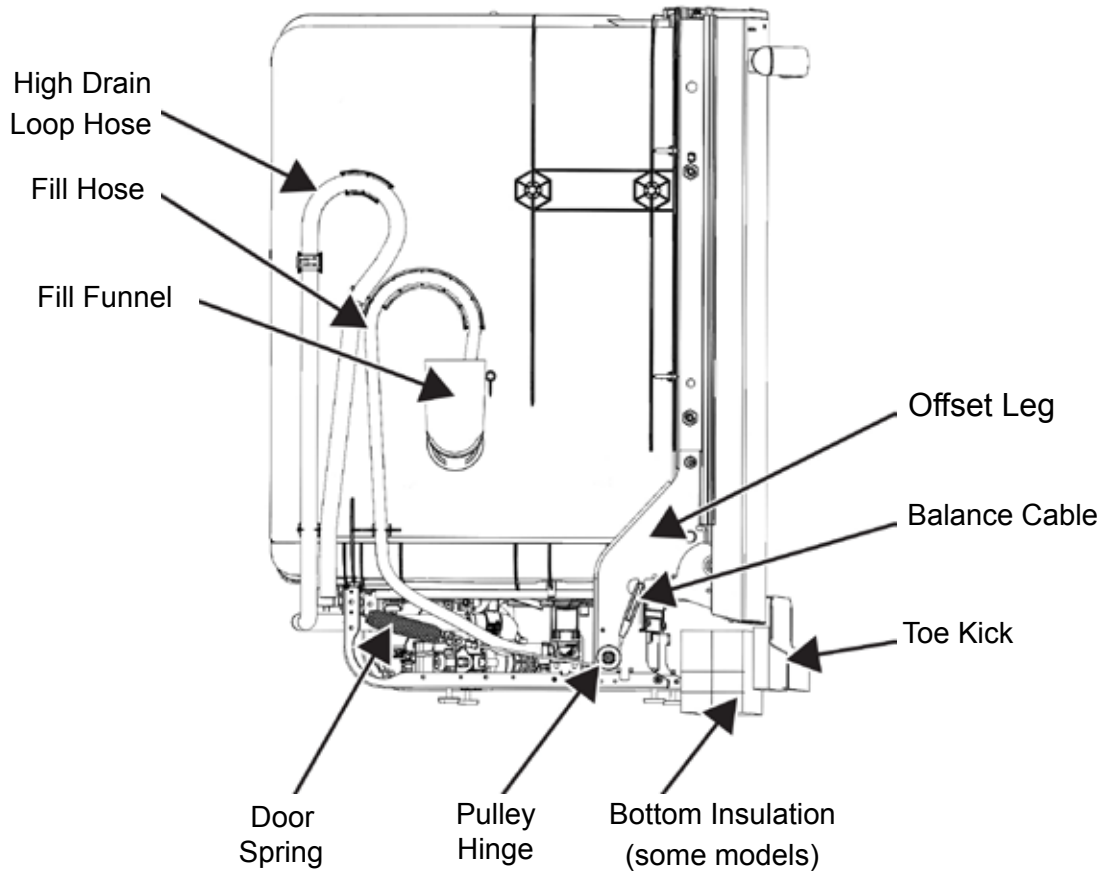

Back

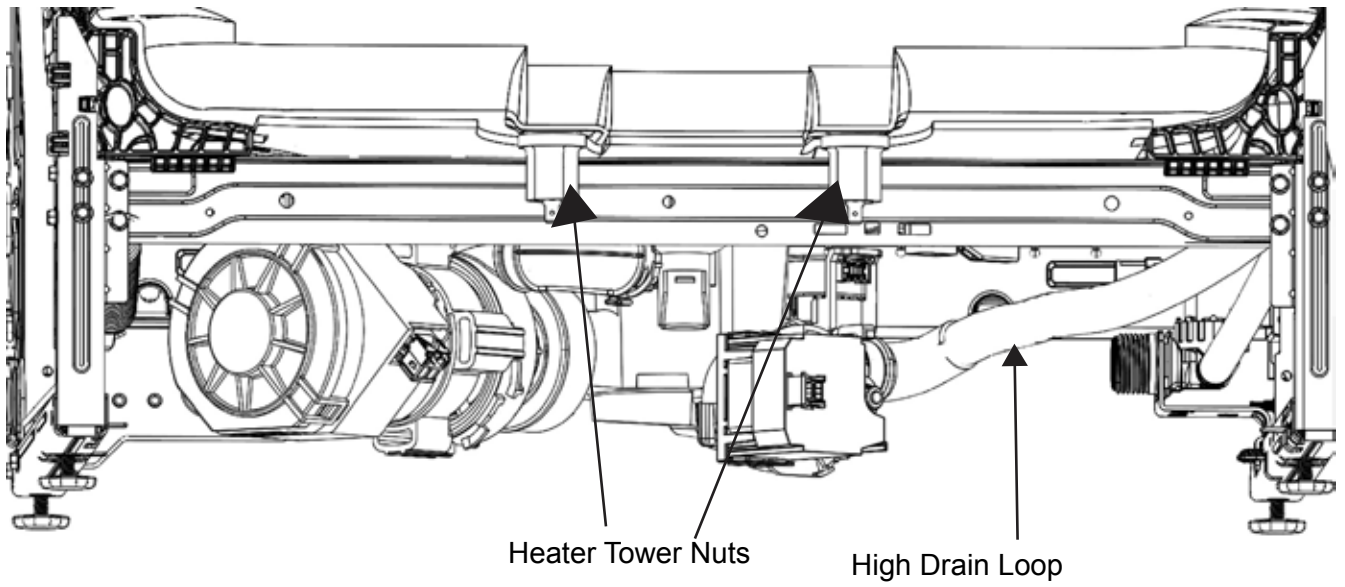

Bottom

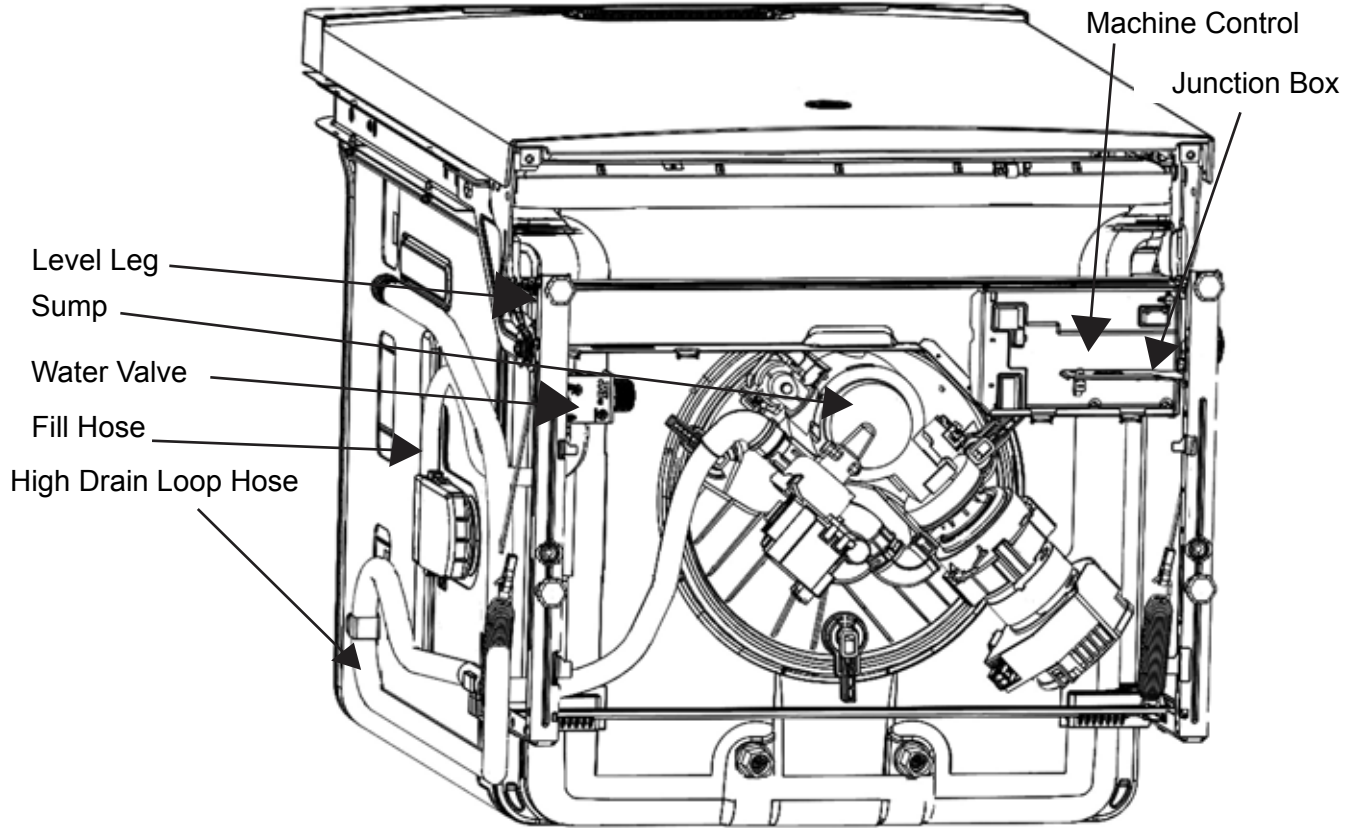

Sump (Top)

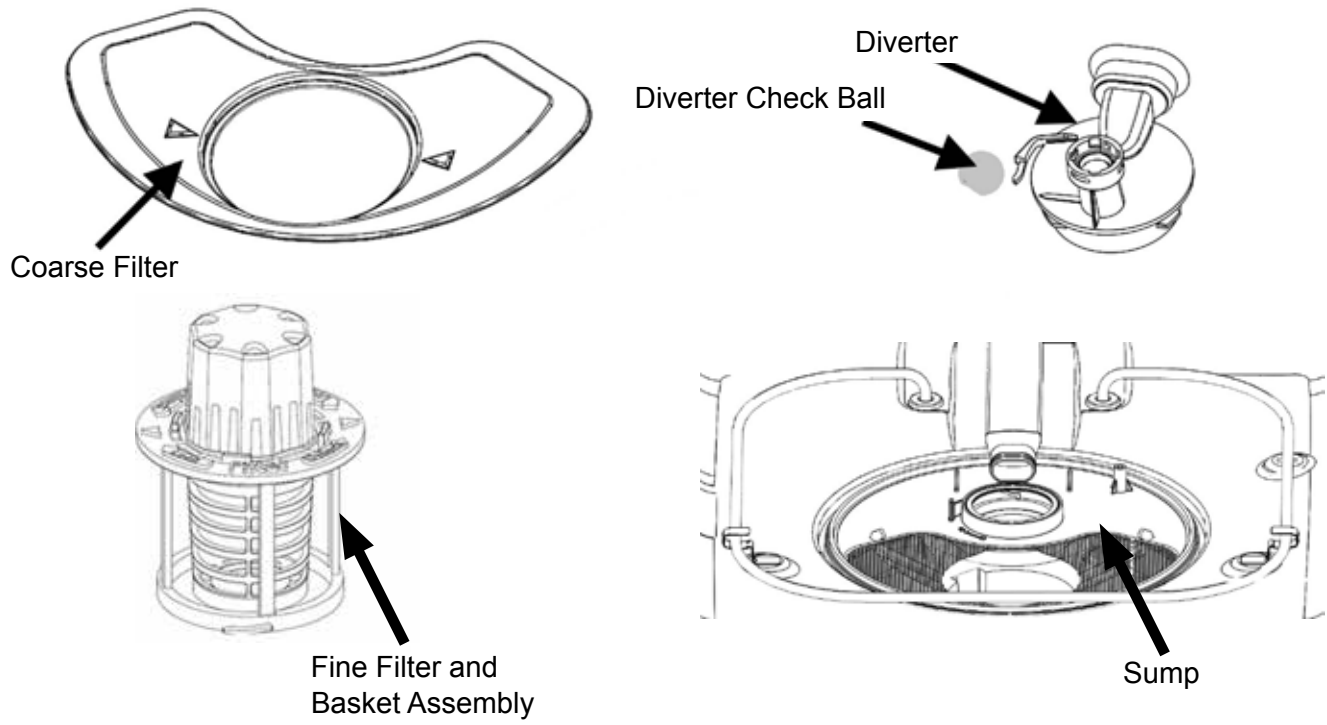

Sump (Bottom)

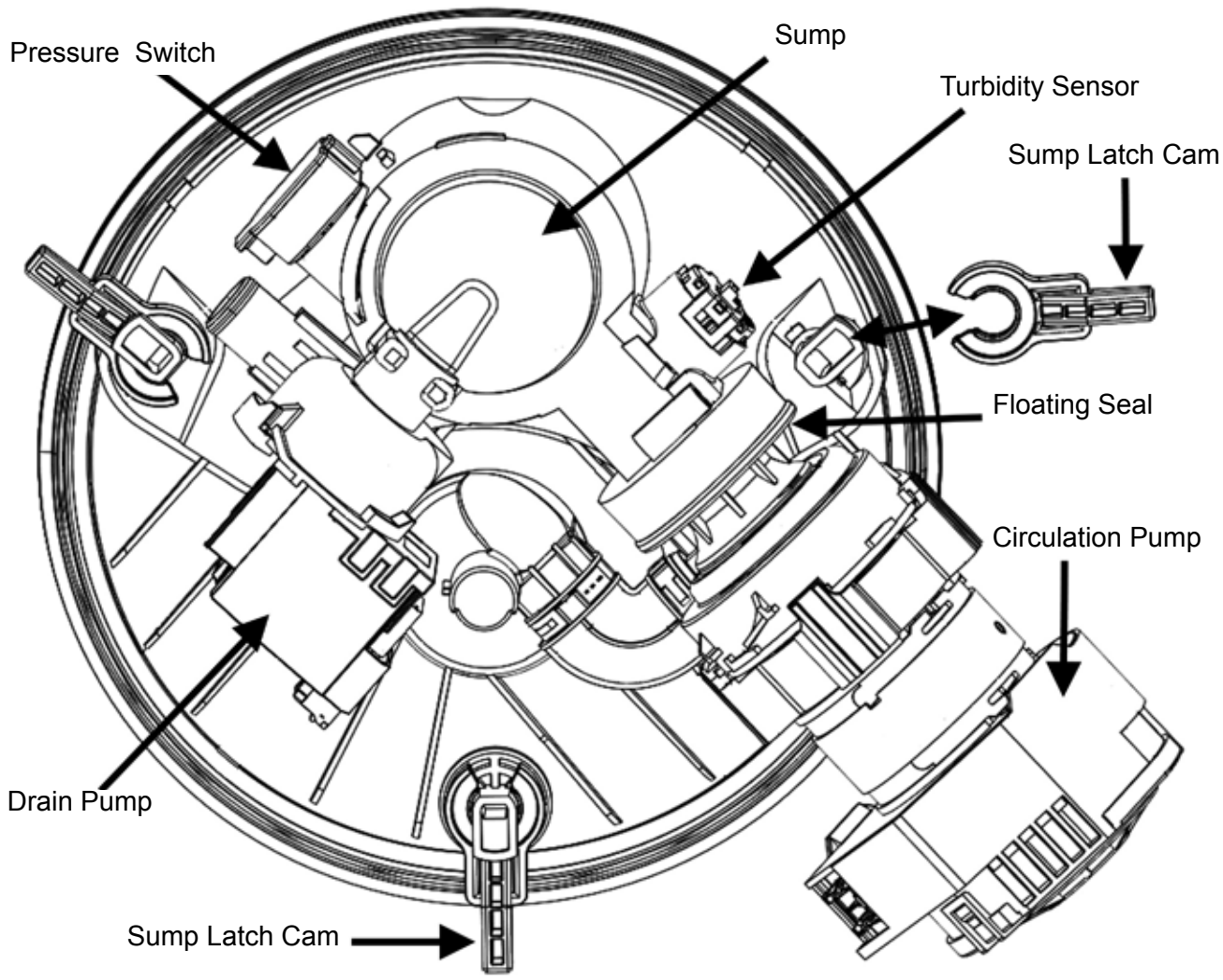

Inside



Racks

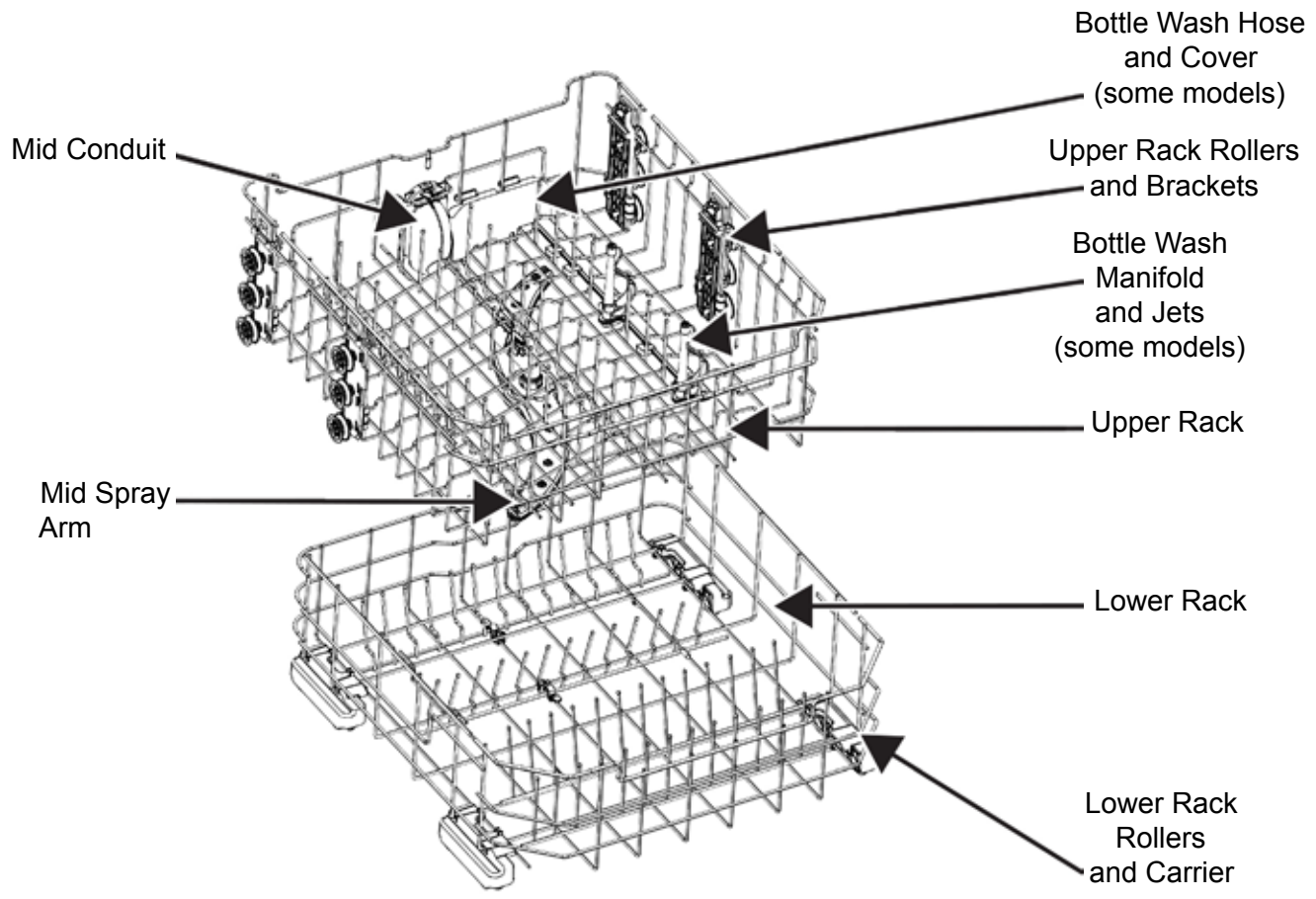

Tub and Structure

The tub and structure section of this guide will cover the toe kick, junction box, racks, leveling legs, door balance, gaskets, trim (on some models), main control board, door, door components, as well as the removing and separation of the screwless appearance door. It will also cover the sump module and removal. Details of the sump components will be covered in the **Circulation System** or **Drain System** sections of this service guide.

Tub Trim (Some Models)

Some models include tub trim which clips to the plastic tub to reduce sound levels and provides a cleaner appearance to the installation.

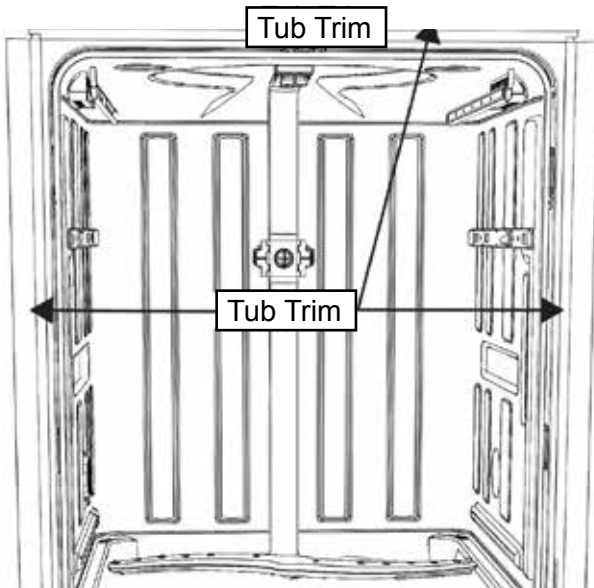

If the cutout prevents the dishwasher from being fully installed, or if the trim rolls inward preventing the door from closing, it may be trimmed to fit properly. The wiper edge must contact the cabinet to be an effective sound barrier.

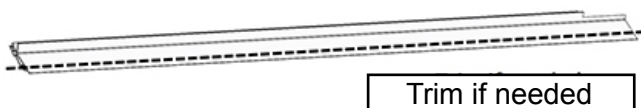

WARNING: GEA Factory Service Technicians are REQUIRED to follow Lockout / Tagout (LOTO) 6 Step Process prior to beginning repair.

Toe Kick

The toe kick is a decorative panel covering the machine area of the dishwasher. The panel provides a safety barrier, closing the front of the dishwasher machine compartment. The toe kick prevents injury from electrical components under the dishwasher. To remove the panel, remove two 1/4-inch hex-head screws and pull the panel away from the dishwasher.

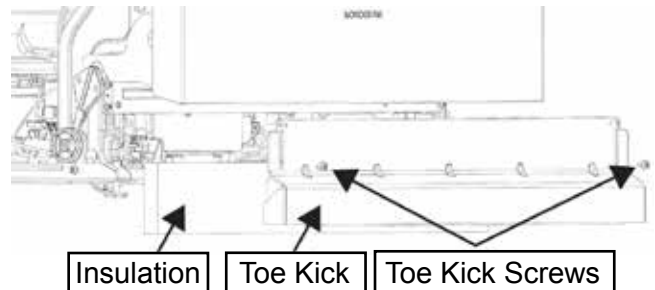

Junction Box and House Wiring Connection

The junction box is located behind the toe kick on the right-hand side of the dishwasher. The junction box is where the 120 VAC house voltage connects to the dishwasher. The dishwasher may be hardwired or an optional cord may be installed (available separately, **Part #:** WX09X70910), which plugs into a wall outlet and connects to the harness plug into the control (see the separate Installation Instructions for more information). The cover is held in place with a 1/4-inch hex-head screw on the left side, and tab on the right side. To remove the cover, remove the screw and pull out and to the left to release the tab.

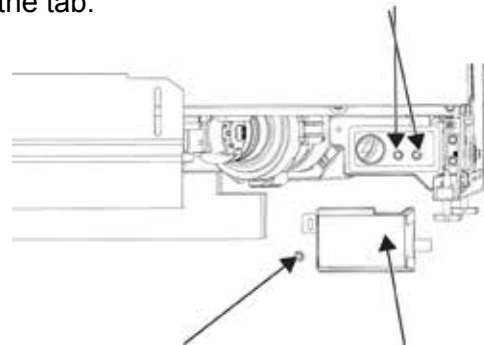

Leveling Legs

There are four leveling legs located on the base rails of the dishwasher.

To access the leveling legs, remove the toe kick and insulation (on some models). To raise the dishwasher, turn the leveling legs clockwise (CW). Turning the legs counter-clockwise (CCW) will lower the dishwasher.

If a leveling leg will not keep the dishwasher level because the support rail is stripped, the dishwasher may be repaired by using two 1/2-inch hex-head nuts with 1/4-inch -20 thread size as jam nuts (**Part #: WR01X10044**), one below the rail, the other above the rail.

Place one nut on the leg and install the new leg onto the dishwasher. Use the bottom nut to level the dishwasher. When it is level, use the remaining nut on the top to firmly secure the leg to the base rail or frame.

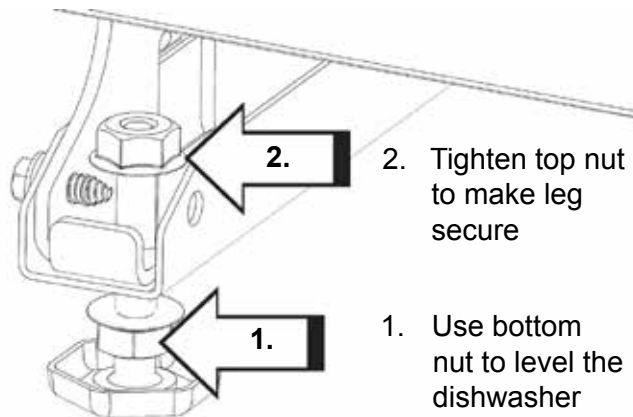

Door Balance System

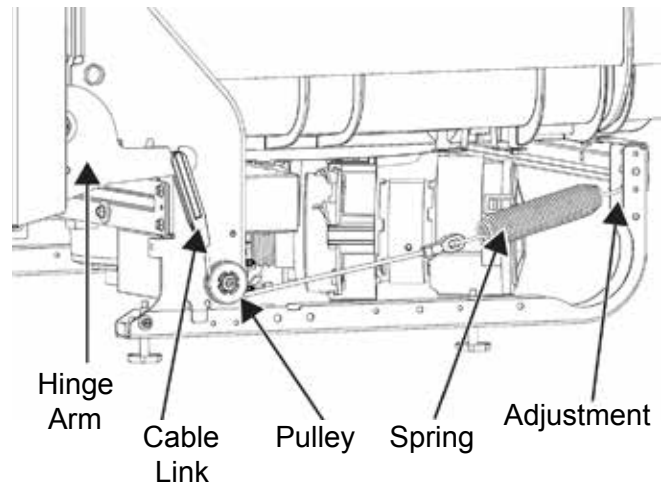

The door balance system is comprised of springs, cables, rollers, and hinge arm.

Door Springs and Cables

The spring is adjustable as it attaches to the rear of the vertical leg base assembly. There are four holes in the leg. Higher connection on the rear frame on the leg causes more tension on the spring. The spring connects to a cable which connects to the hinge arm using a roller as a tensioner.

Hinge

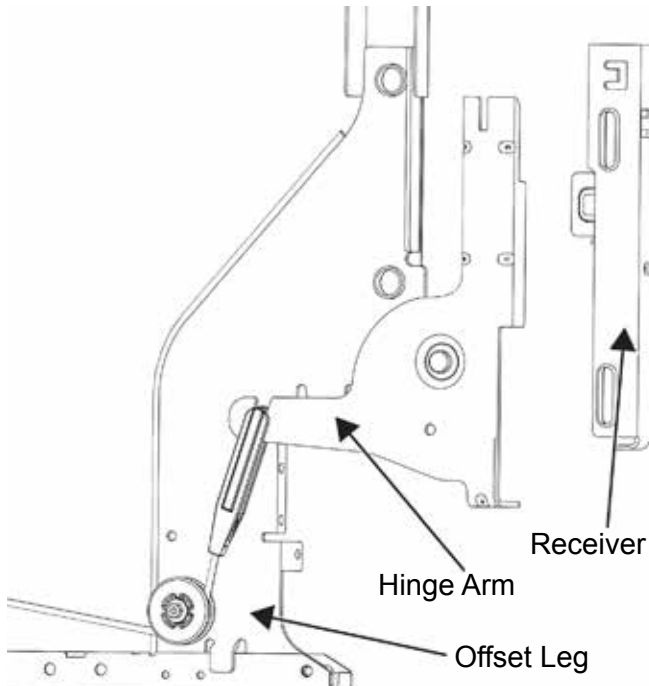

The hinge system is comprised of offset legs (part of the tub and structure system and not a replaceable part), hinge arms, and receivers. The hinge system allows the door to be removed while the dishwasher remains installed.

Information on door removal can be found under the **Door** section found later in this section of the service guide.

Tub Gasket

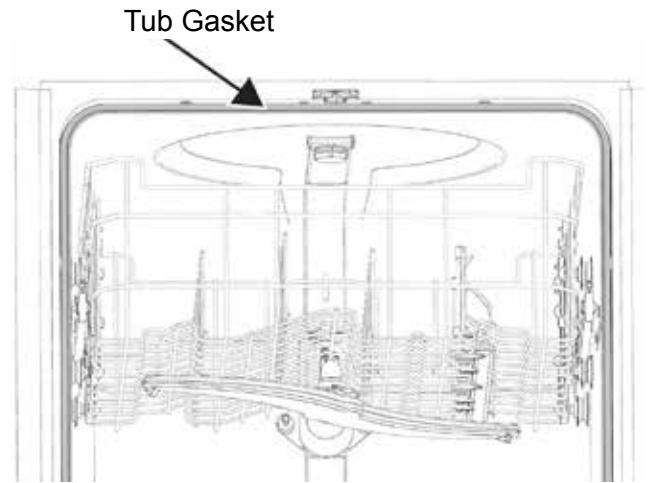

The tub gasket seals the top and sides of the tub to the door. The retainer is molded into the PermaTuf tub. The seal pushes into the retainer area of the tub, and no sealant or RTV is used to install the tub gasket. There is a stop molded into the tub to provide a proper position end point for the gasket.

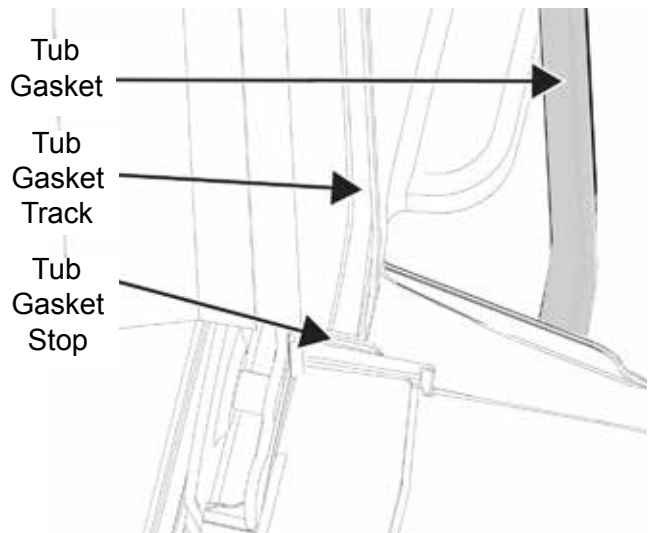

Tub Gasket Installation

1. The center of the gasket has a mark which is placed pointing to the inside of the dishwasher. This position will orient the gasket wiper to face the inside of the dishwasher and to the inner door.

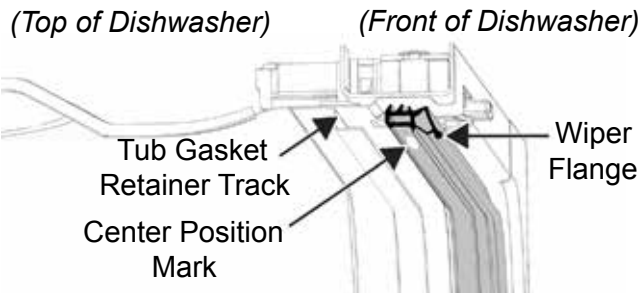

2. Start by placing the mark down and align with the tub latch. Push the gasket into the track, working outward to the top corners.
3. Push the gasket into the track through the corners, making sure the wiper portion of the gasket does not turn inward or outward causing the gasket to not have an even plane around the corners. Stretching the gasket may cause the gasket to roll in or out, which will cause the new gasket to leak. If the gasket wiper rolls in or out, pull the gasket out of the track and reinsert into place.

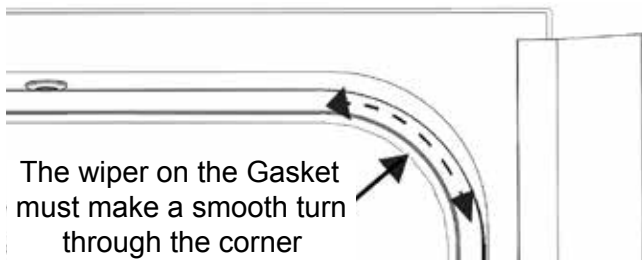

4. Continue to push the gasket into the track to the track stopping point at the bottom of the tub.

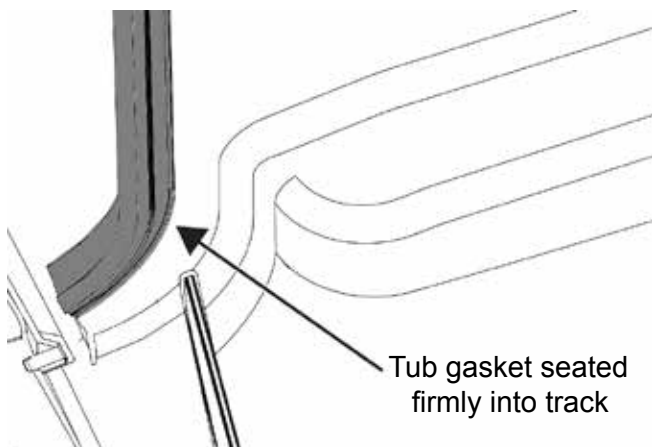

5. Always run the dishwasher to test for leaks.

Latch System

The latch system is comprised of a latch striker and tub latch.

The tub latch switches are rated at 13.5 VDC. The door latch switches open and close the line and neutral break relays on the main control. The tub latch is located on top of the tub. A strike on the door activates the switches, and the tub latch holds the door in when the door is latched closed.

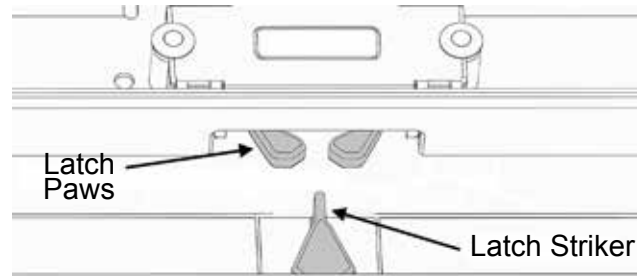

The dishwasher must be pulled out 6- to 8-inches from its installed position to replace the tub latch.

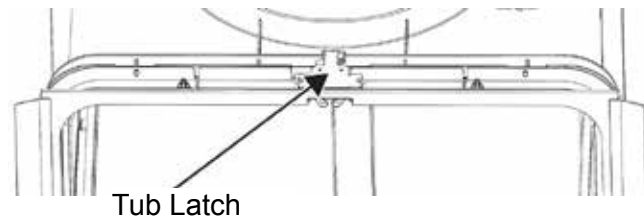

To Replace the Tub Latch

1. Remove power to the dishwasher.
2. Remove the dishwasher from its installed position, approximately 6- to 8-inches.
3. Remove two screws, (R2 Robertson / Carpenters Bit or #2 Phillips screw-driver).

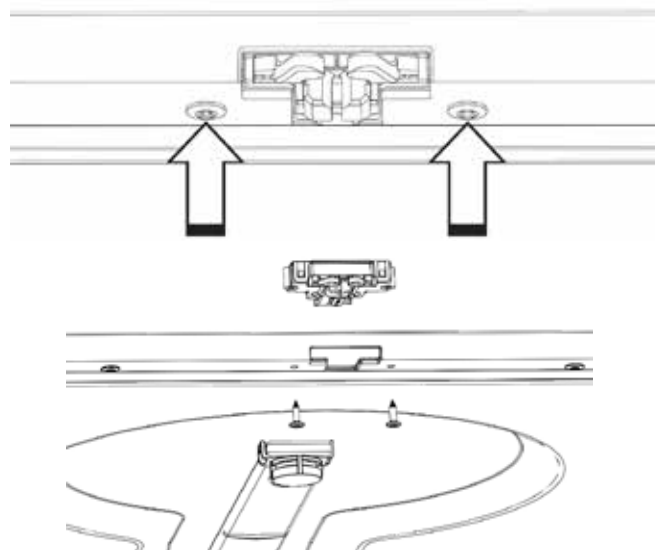

Tub Latch Switch Diagnosis

Diagnoses can be accomplished in Error Mode (see **Error Mode** under the **Electronic Controls** section of this service guide) or with an ohm meter at the main control board as described below.

1. Access the main board.
2. Locate and disconnect connector J711.
3. Check continuity from pin 3 (**tan and red**) to pin 4 (**violet and yellow**) and pin 3 (**tan and red**) to pin 5 (**white and silver**). Both should be open when the door is open and closed when the door is closed.

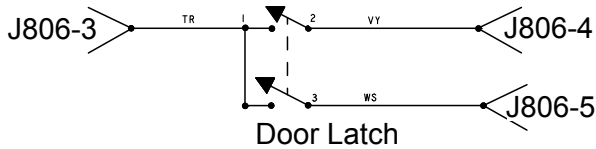

Racks

Upper Rack

Two rack configurations are available, depending on the model: adjustable and non-adjustable. Both are similar in design of rails and rollers.

- **Non-Adjustable Upper Rack**

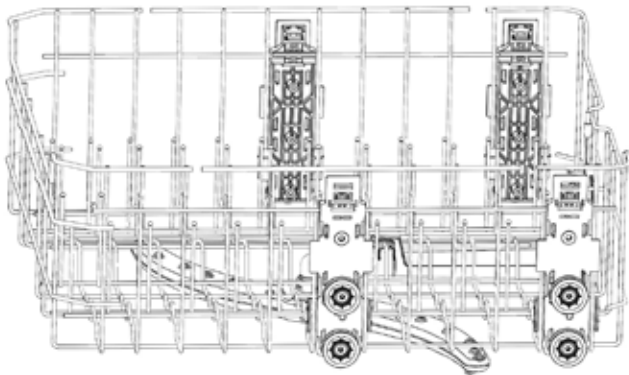

To remove the rack from the dishwasher, pull the rail assembly out a few inches for easier access. Press the tab on the end cap to the center of the dishwasher and pull the end cap off the rail.

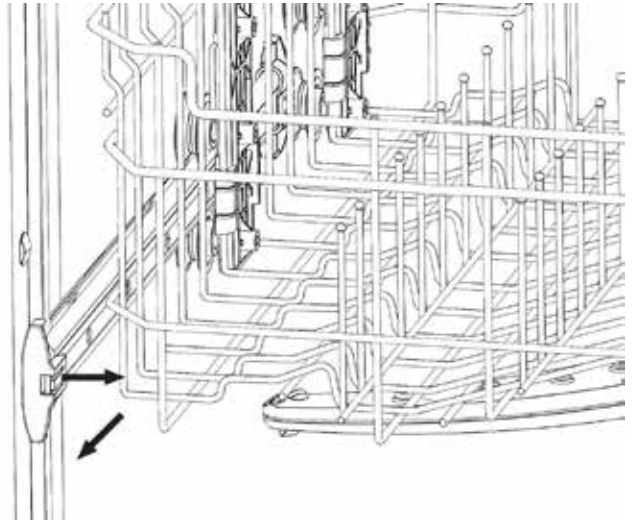

The rack may now be removed.

Upper Rack Rollers and Brackets

The upper rack roller brackets are locked into place with a clip. The clip must be removed to remove the roller brackets from the rack. Press in on the tab and lift the locking clip.

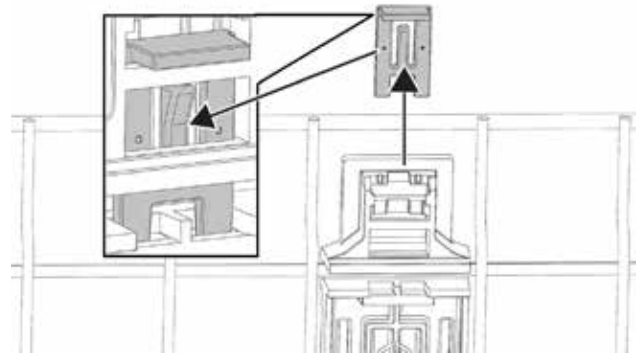

The tub rollers are attached to the tub with a screw in each roller.

To Remove the Tub Rollers

1. Remove the upper rail by removing the rear end cap.

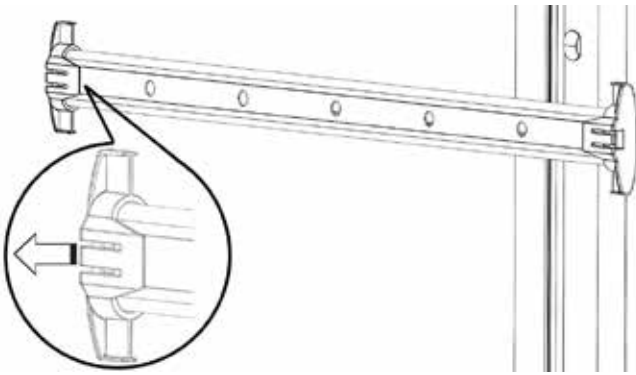

2. Remove the T20 Torx-head screw securing each roller to the tub.

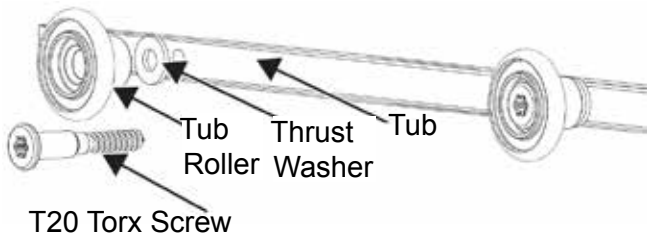

Adjustable Upper Rack

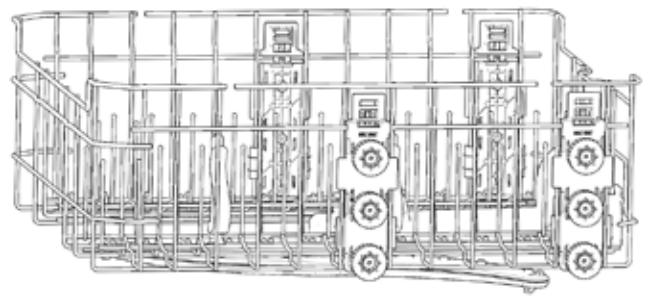

The upper rack may be pulled out to stop and lifted to adjust to a higher or lower position.

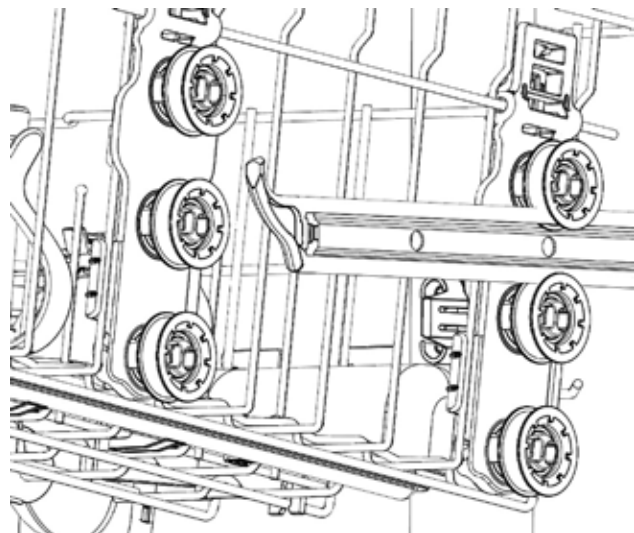
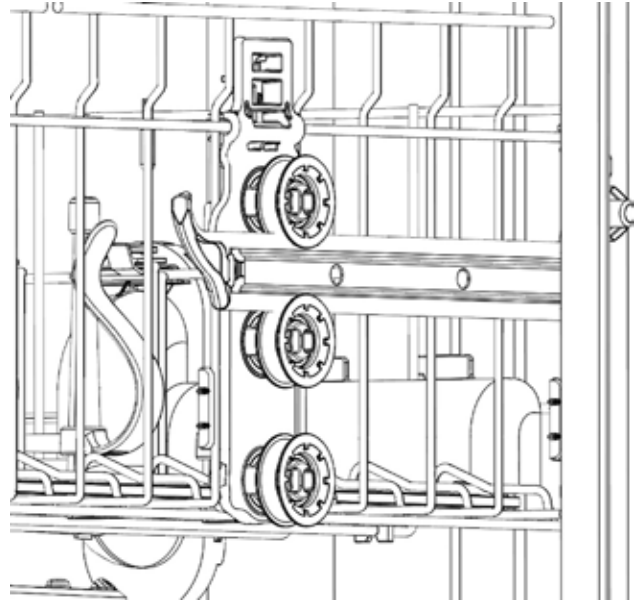

The front-end cap is assembled to the rail. If it needs to be replaced, the rail will need to be replaced.

The rail may be removed from the dishwasher by releasing the tab on the rear end cap.

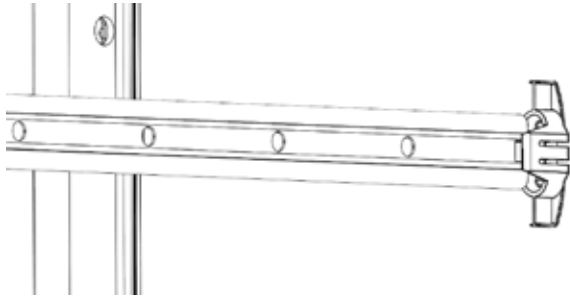

Slide the bottle wash manifold to the front of the rack.

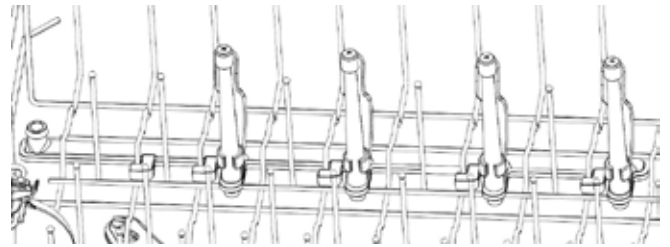

To remove mid conduit, push on the tab, and slide the conduit to the back of the rack.

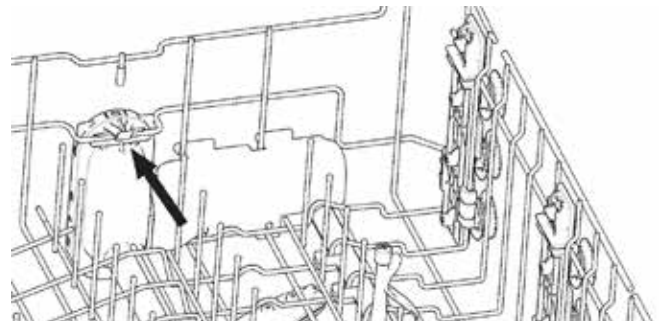

Upper Rack Bottle Wash

Some models have a bottle wash system on the upper rack. It was designed to wash dishes with small mouths at the top of a container such as sports bottles.

To remove the bottle wash components, remove the cover by releasing the clip at the bottom and slide the cover to the right.

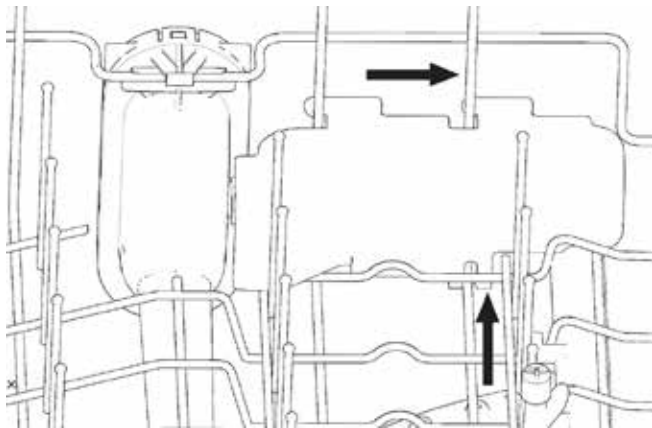

Disconnect the hose.

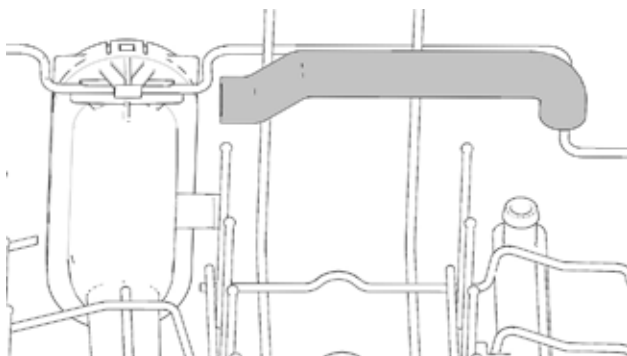

Lower Rack

Several lower racks are available with different tine configurations; consult the Owner's Manual for details on the lower racks.

The lower rack roller assemblies consist of brackets and rollers. They are universal and can be used on either side of the lower rack.

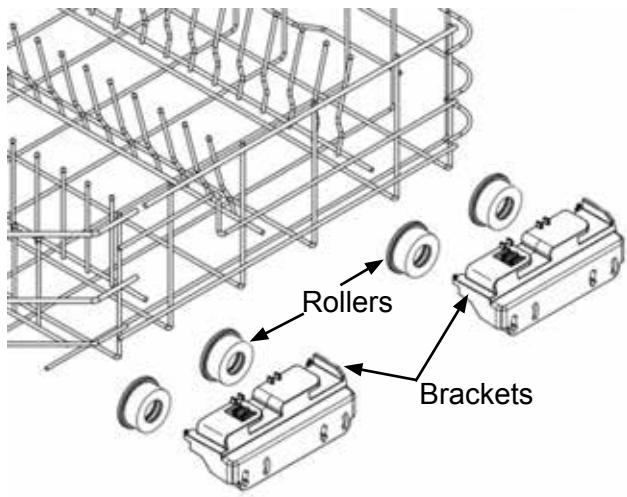

To remove the lower rack brackets, insert a flat-blade screw-driver under the tab and pry up. Then slide the assembly off of the rack.

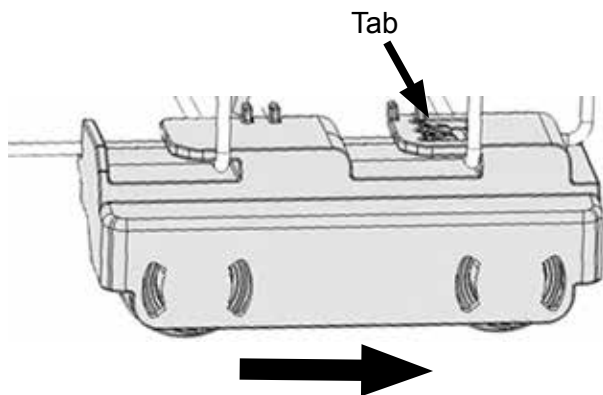

Pinch the clips inward and pull the rollers off of brackets. **Note:** When reinstalling the rollers onto the bracket, ensure clips are fully engaged by tugging on the rollers.

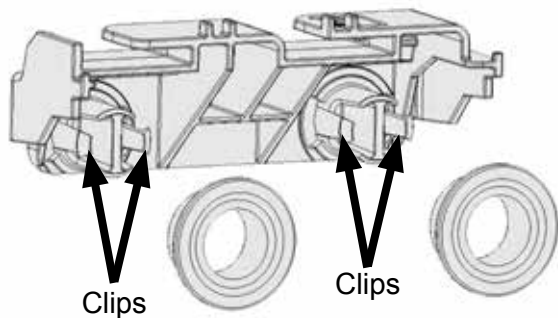

Door

The door has a screwless appearance. The door contains a user interface (UI) board with all tactile switches on the board. Some models have a 7-segment display (SSD); others have LED indicator lights. The door also houses the detergent module, bottom door seal and a passive venting system (see the **Dry System** section in this service guide).

Door Removal

1. Remove power to the dishwasher.
2. Remove the toe kick.
3. Disconnect the door wire harness at the bottom of the main control cover.



4. Release the wire clip holding the harness to the tub.

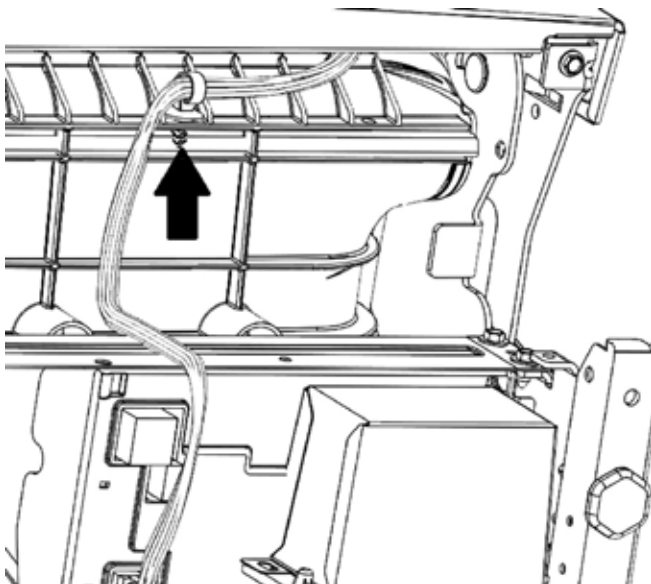

5. Remove two 1/4-inch hex-head screws at the bottom of the door.



6. Locate the hinge pin locking point hole in tabs of the left and right side of each offset leg (left side shown below).

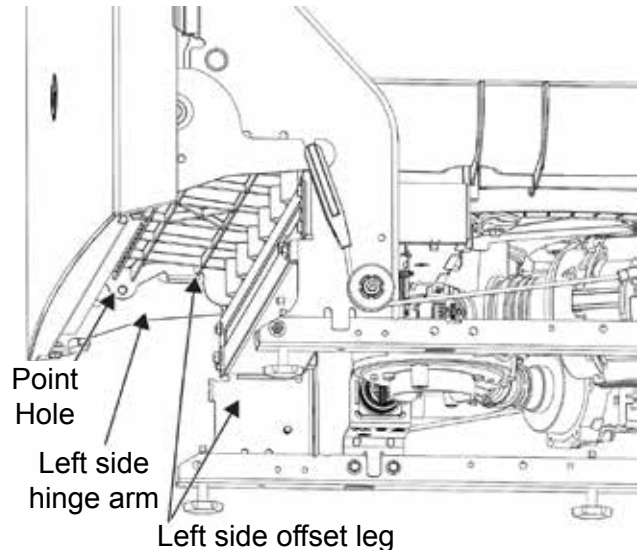

7. Insert a 5/32 Allen wrench (or similar size tool) through this hole, gradually open door to 30 degrees and continue to insert the Allen wrench through both the offset leg and hinge arm, until locking of the hinge has completed.

TIP: Using a “tool” with a tight fit will produce the best results and easier door installation.

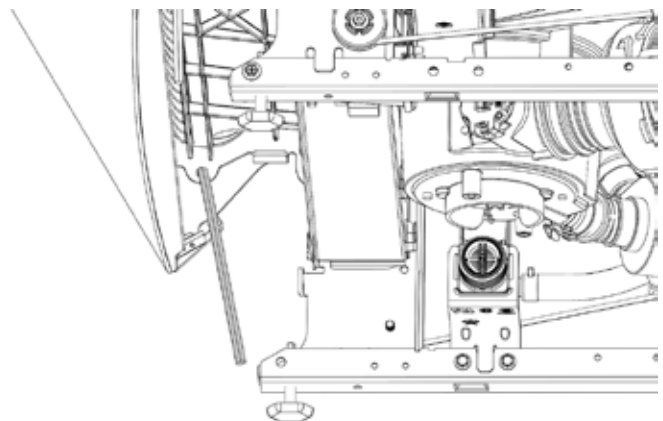

8. Repeat the last step on the opposite side.

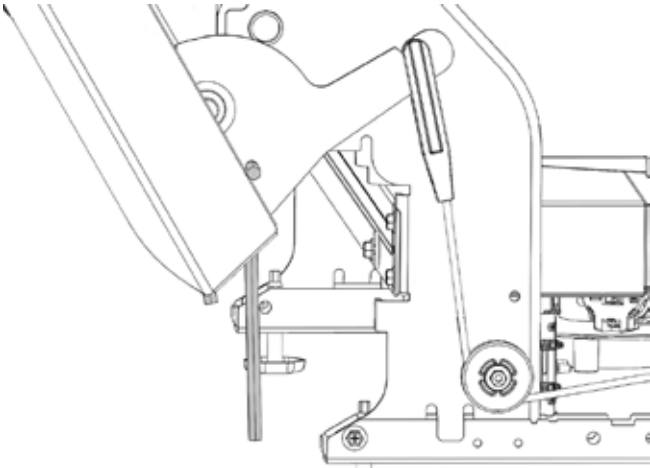

9. Lift the door up approximately 3-inches.

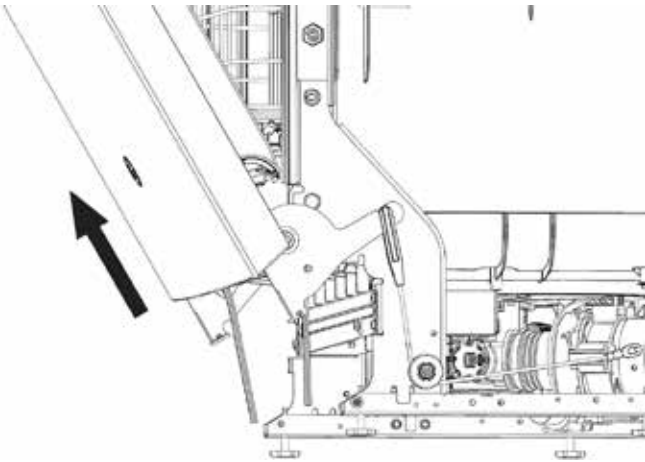

10. Tilt the door in (vertical).

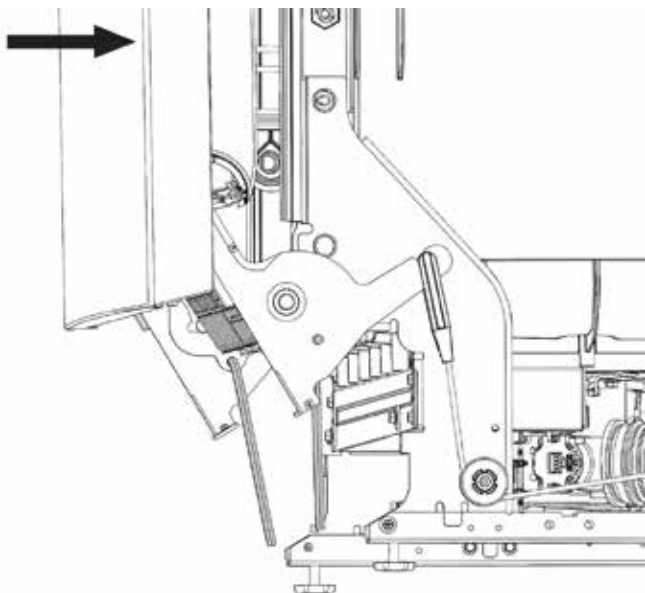

11. Lift the door off of the dishwasher.

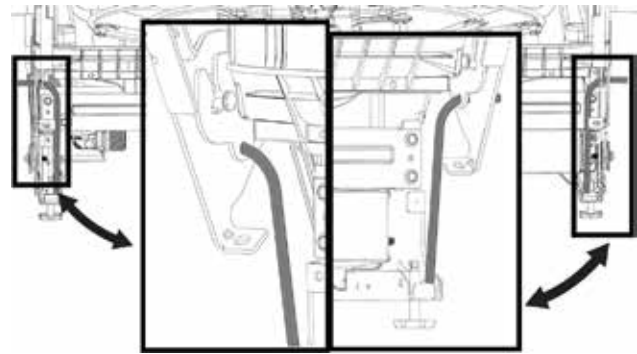

Door removed.
Hinge arms locked with Allen wrenches

Door Reinstallation

1. Let the door hang vertical and start by guiding the door onto the hinge arms.
2. As the door drops approximately 2-inches, let the top of the door fall away from the dishwasher and it will drop into place.

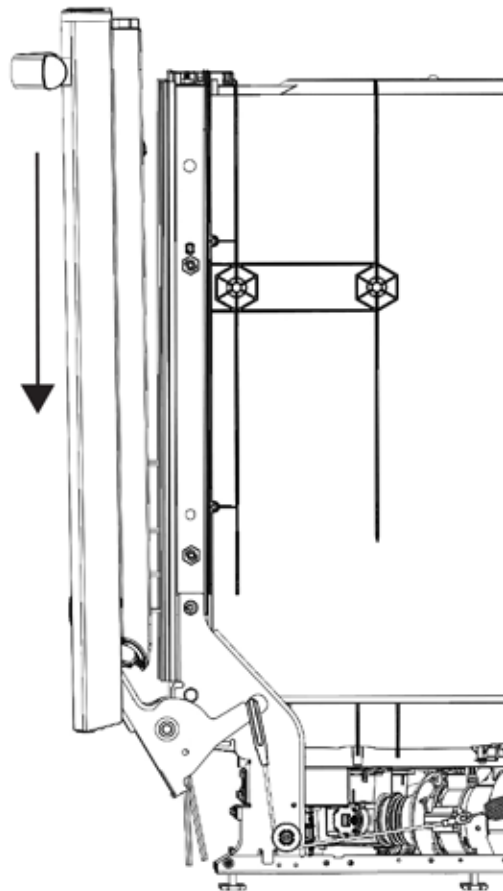

WARNING: GEA Factory Service Technicians are REQUIRED to follow Lockout / Tagout (LOTO) 6 Step Process prior to beginning repair.

Inner Door Vent Cover

The inner door vent cover must be removed to separate the top control doors and to remove the front control console from the inner door. Insert two pocket-style flat-blade screw-drivers into the vent, then turn counter-clockwise (CCW) to remove.

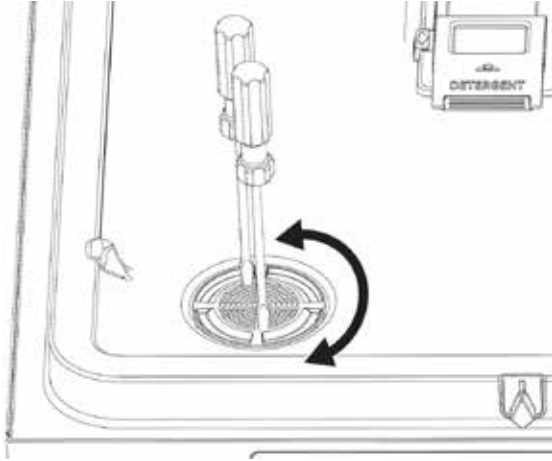

To Separate the Door

1. Remove the door.
2. Remove the inner door vent cover.
3. Place the door on a protected surface to prevent damage (the inner door facing up).
4. Remove the two 1/4-inch hex-head screws.

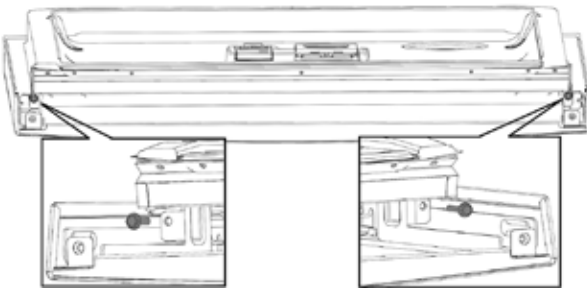

5. Slide the outer door panel away from the console or control panel, approximately 3/4-inches.

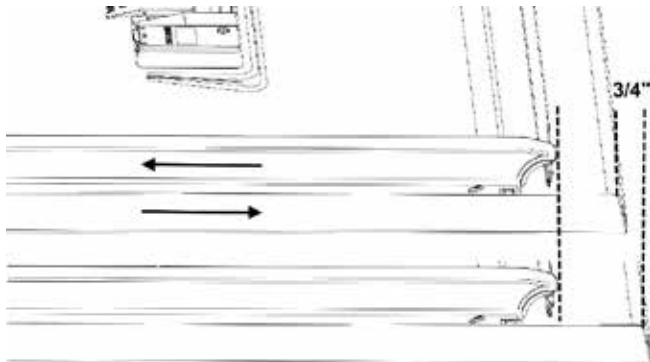

6. Lift to separate inner and outer door panels.

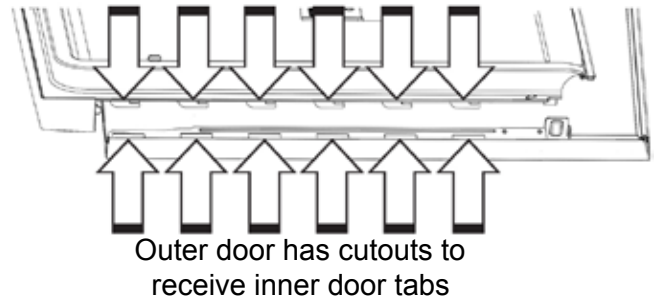

To Reassemble the Door

1. Place the outer panel face down on a protected surface.
2. Place the inner door face up, and position six attachment tabs into the cut-outs of the outer panel.

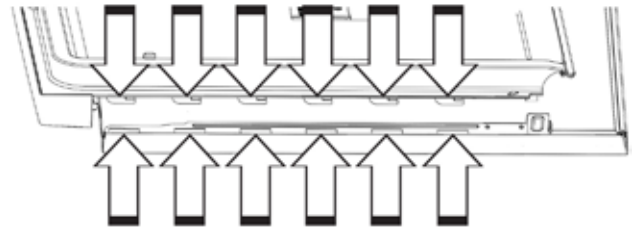

3. Press the tabs firmly together while sliding the inner panel onto the outer panel, using care to make sure the outer panel mates properly to the front or top console. The illustration below has a portion of the door sectioned or cut out to show the outer door panel engaged with the attach tabs of the inner door.



4. Reinstall screws, inner vent cover and reinstall the door.

Front Control Console

The front control console is held in place by four tabs on the pocket handle.

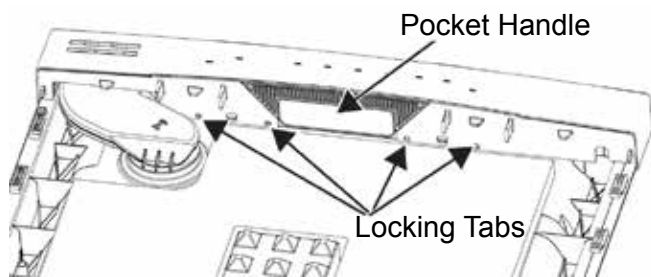

Front Control Console Removal

1. Remove the door and separate the inner and outer door panels.
2. Remove the vent cover from the inner door.
3. Push down on the pocket handle, then lift up and away from the console on tabs to release the console from the pocket handle.

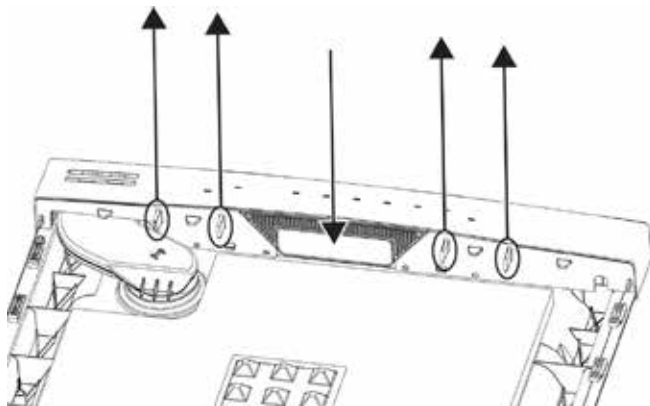

4. Tilt the bottom upward. When both sides are released, rotate the console to release the tabs at the top of the console.

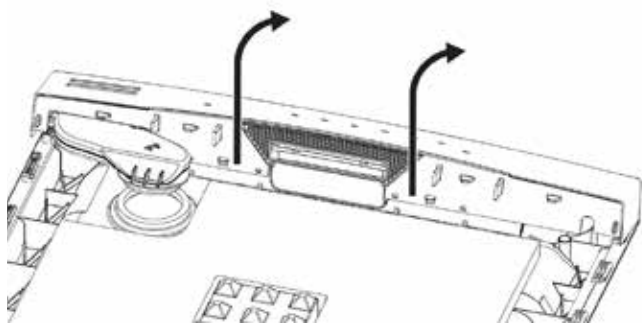

User Interface (UI)

There are several front control user interface (UI) configurations. There is a four-button configuration and a six- or eight-button configuration. There is also a top control configuration. This section will cover the UI and console assemblies. Diagnosis is covered in the **Main Control Diagnostics** section of this guide.

Front Control UI: Four-Button

A smaller user interface (UI) is used on four button models lowering the overall number of components in the console area.

Rear View of Console

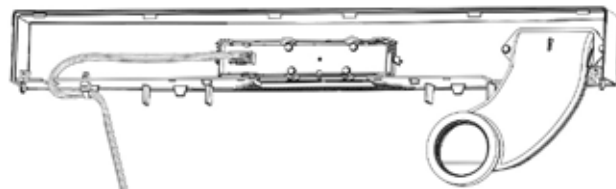

Front View of Console and Components

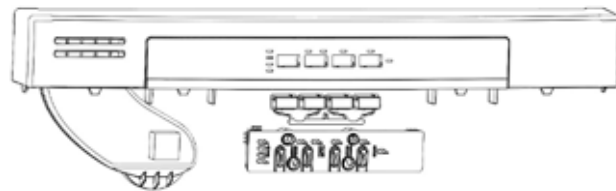

To remove the UI assembly or to access the button tree, remove four 1/4-inch hex-head screws.

Exploded View of Console, Button Tree and UI Assembly

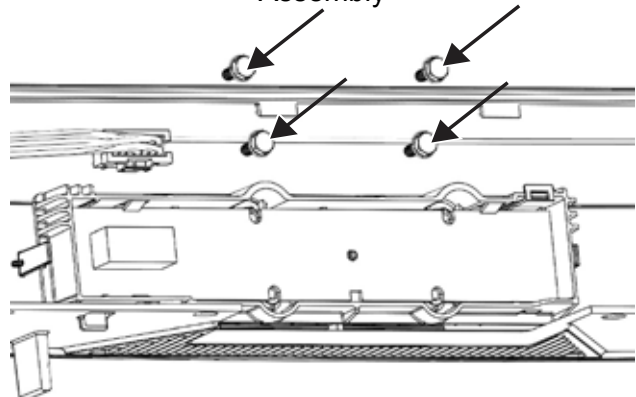

Appearances may vary depending on model number throughout this service guide.

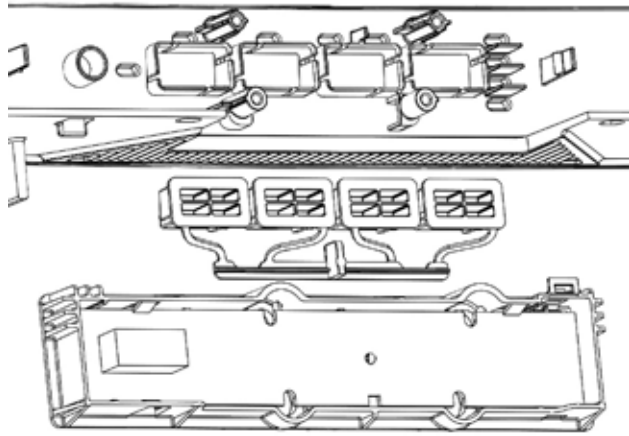

Front Control UI, Light Pipe and Buttons

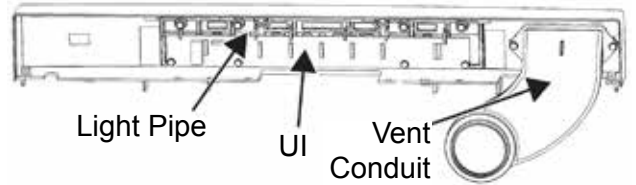

The front control console must be removed and separated to access the UI, light pipe and buttons.

User Interface (UI) Removal

1. Remove four 1/4-inch hex-head screws at the bottom of the UI board and cover.

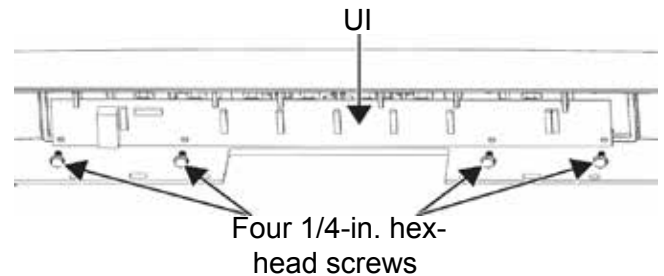

2. Tip the bottom of the UI to release from top tabs.

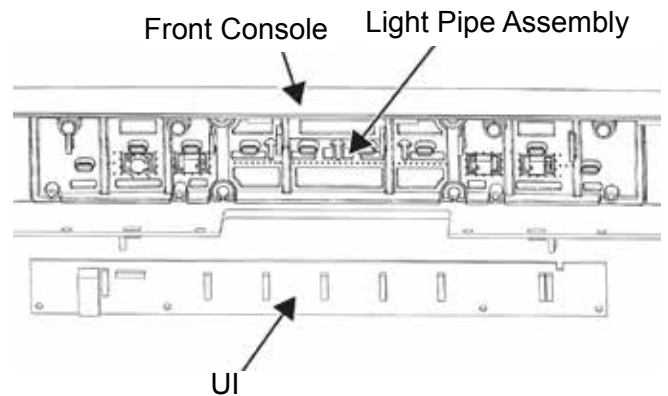

3. To remove the light pipe assembly, remove four 1/4-inch hex-head screws at the top of the light pipe.
4. The light pipe and buttons may now be removed.

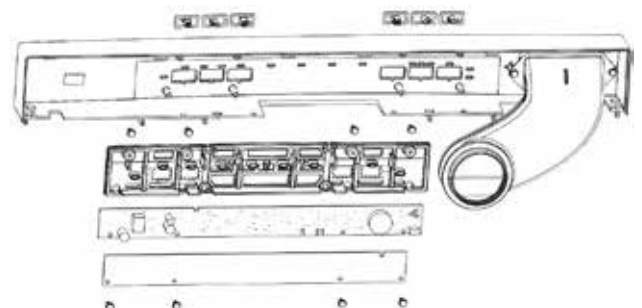

Pocket Handle (Front Control Only)

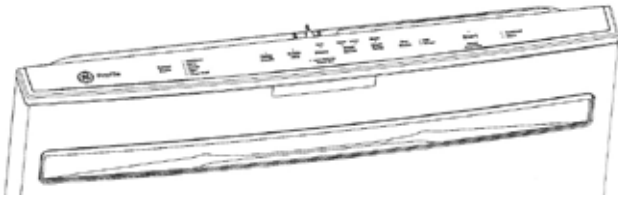

The pocket handle is attached to the inner door panel. The front control console must be removed as previously described in **Front Control Console Removal** (in this section). Remove six 1/4-inch hex-head screws.

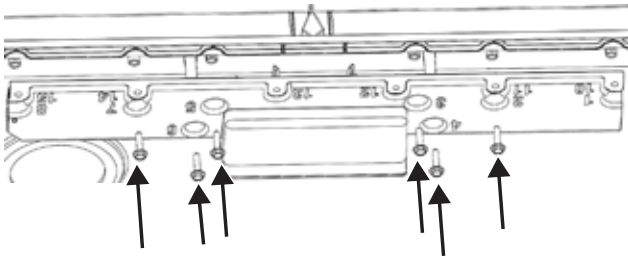

The pocket handle is clipped to the plastic inner door and on the adapter of the stainless steel (SS) inner doors.

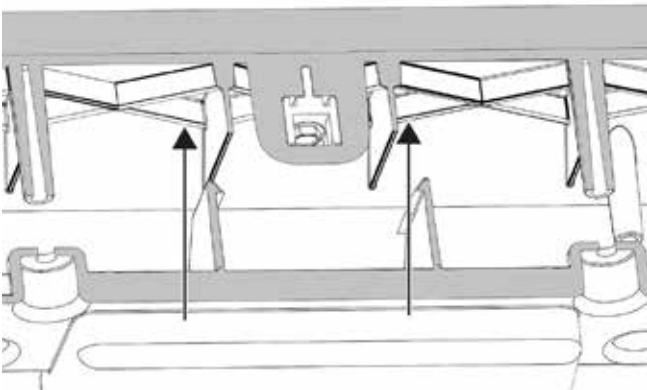

Pocket Handle (GDP615)

Model GDP615H features a new pocket handle design and has top controls.

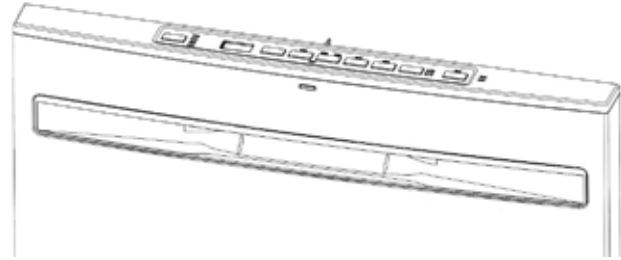

The new pocket handle is attached to the outer door panel with seven 1/4-inch hex-head screws.

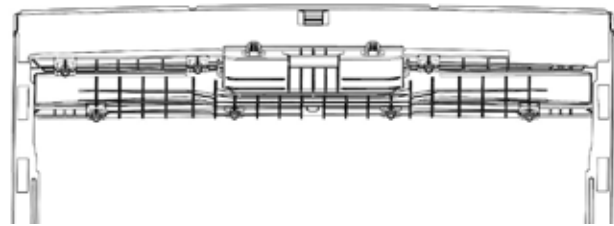

To remove the handle, remove and separate the door. Remove seven 1/4-inch hex-head screws. The handle can be removed toward the inside of the panel.

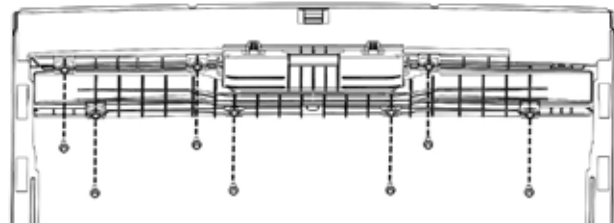

Fan Assist Dry (On Some Models)

A pocket handle and fan assist dry are new to the plastic tub line in model GDP615.

The dry components are identical to the dry system used in stainless steel tub models since 2013 (see below).

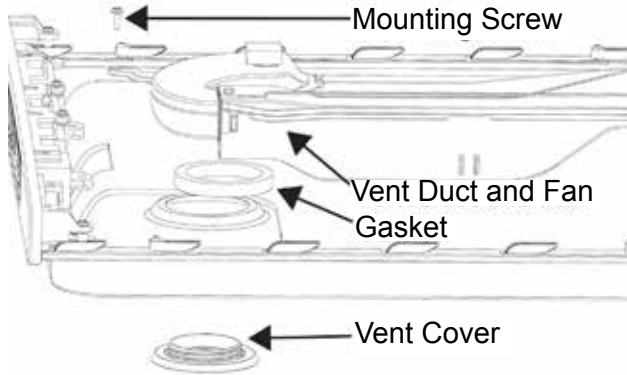

Top Control Panel, UI, Light Pipe and Buttons

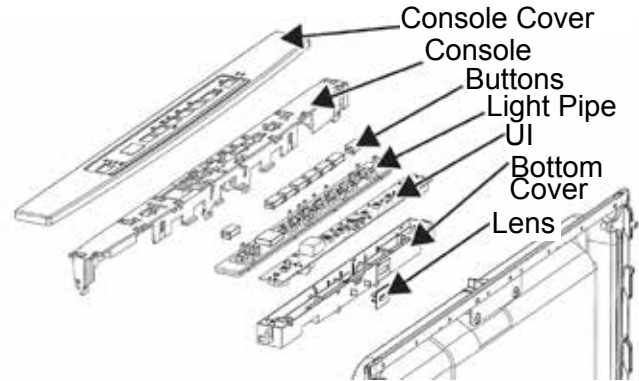

Access the User Interface (UI), Control Covers, Buttons and Light Pipe

1. Remove and separate the door.
2. Remove four 1/4-inch hex-head screws.

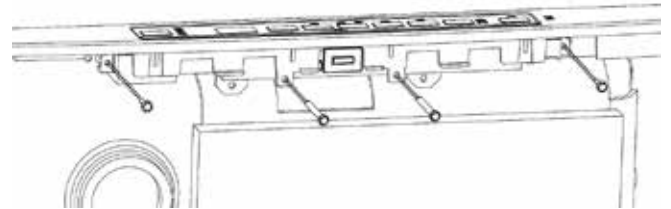

3. The console cover and bottom cover will drop down from the control panel.

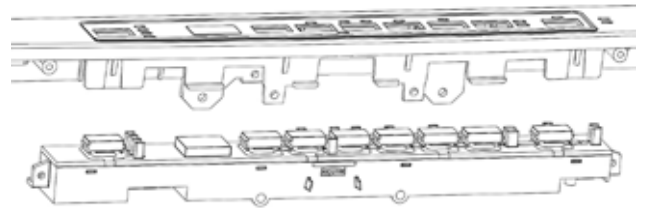

4. The buttons, and light pipe with silicone pad will be removed from the bottom cover to access the UI.

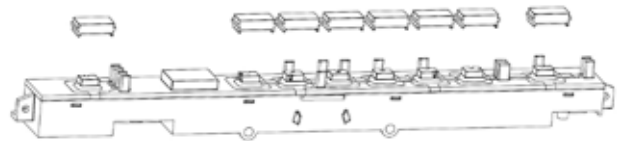

- The light pipe separates from the bottom cover with tabs. A small screw-driver may be needed to start the first tab.

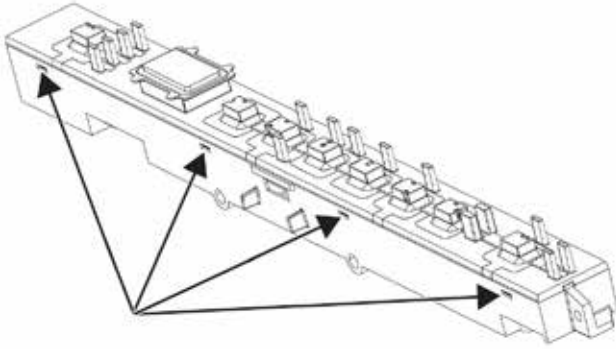

- The light pipe may be flexed by twisting to release the remaining tabs (four each side).

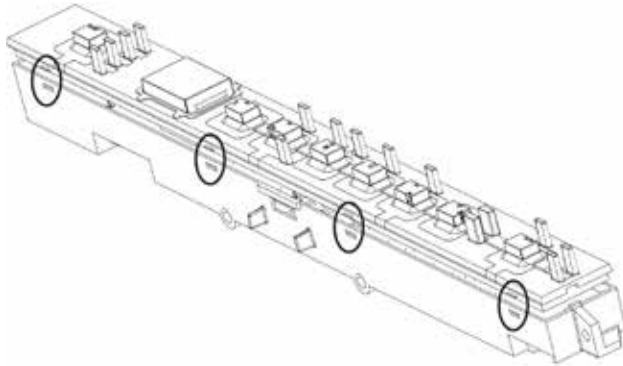

- With the light pipe removed, the user interface (UI) may be lifted out of the bottom cover.

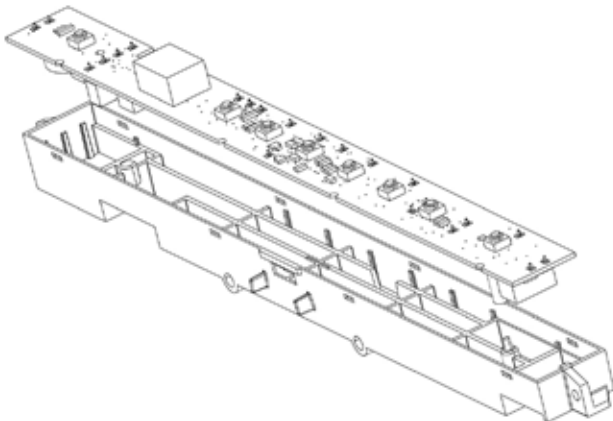

- When replacing user interface (UI) control boards, the new UI board must be configured as per instructions included with the replacement. If the personality is not set by using the four jumpers, the buttons, LED's, or cycles will not function properly.
- Diagnostics for both front and top control UI's are found in the **Electronic Control** section of this service guide.

Top Control Console Cover

Top Control Console Cover Removal

- Remove and separate the door.
- Remove the bottom cover, user interface (UI), light pipe and buttons.
- Remove the top console and cover as an assembly. There are six 1/4-inch hex-head screws, securing the assembly to the inner door (note the length of the screws). A new cover should be replaced in the event the cover is loose or must be removed. The tabs are likely to break on removal.

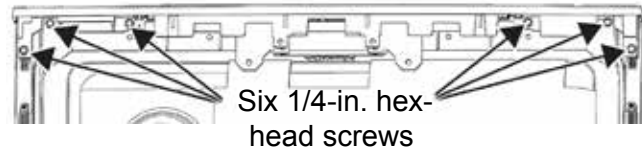

Installing a New Top Cover

- The top cover is secured with sixteen tabs, and the console has cutouts or slots to allow the top cover to click lock together.



- Position the tabs on the cover into the slots on the console.

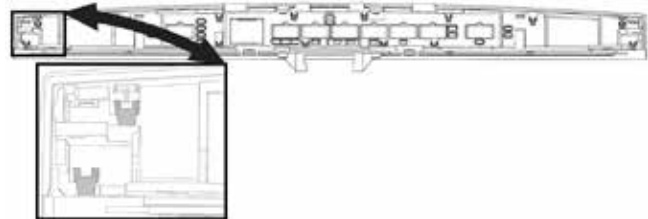

- Press the top and console securely together and slide the parts to engage the tabs into the slots. Start from one end and work across to the other end. A series of five audible clicks will be heard as the cover and console snap together.

Outer Door Panel

Outer Door Panel Components

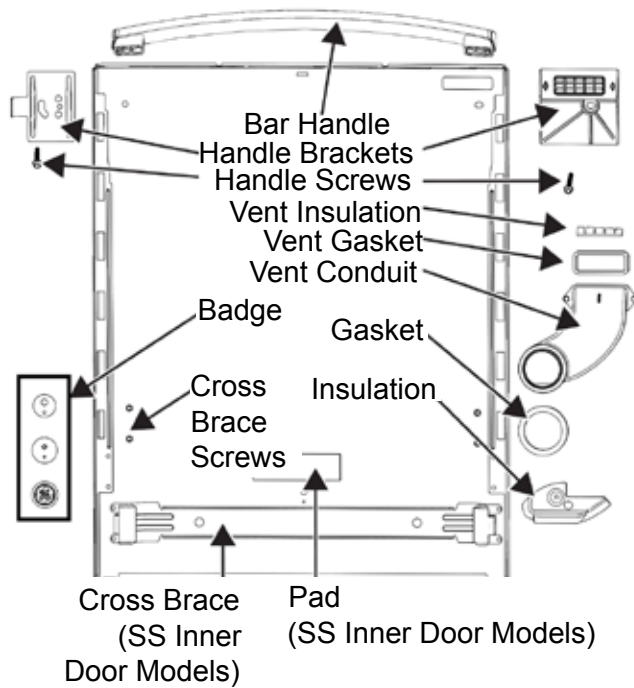

Bar Handle

The bar handle is attached to the outer door panel. The handle is an assembly with end caps pre-attached.

Bar Handle Removal

1. Remove and separate the door.
2. Remove the vent conduit (two 1/4-inch hex-head screws).
3. Remove two 3/8-inch hex-head, 1/4 -28 thread size screws holding the handle.

Inner Door Panel

Stainless Steel (SS) Door Attach Strips

Attachment strips are used on stainless steel (SS) door attach strips models only; plastic inner doors have this feature molded into them. Strips also have a boss on each side for the screw to secure the inner and outer door panels.

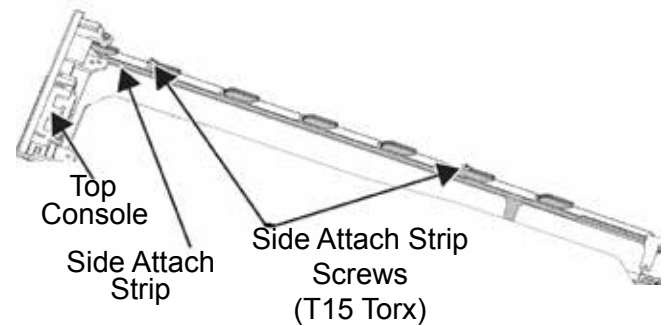

Attachment Strips Removal

1. Remove and separate the inner and outer door panels.
2. Remove the front control console or top control panel.
3. Remove the two T15 Torx-head screws on the side attach strips.

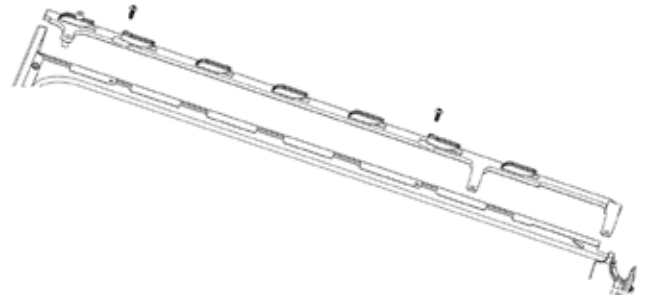

4. Slide the strip inward to remove.
5. To remove the top attach strip, slide the strip down after the top console and side attach strips have been removed.

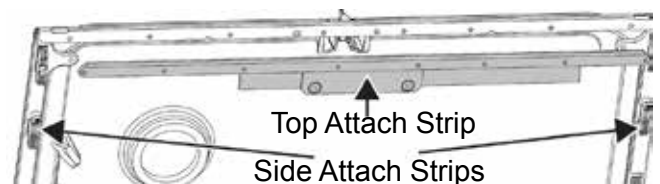

Door Gasket

1. Remove the door.
2. Place the door on a protected surface to prevent damage.
3. On plastic inner door models, slide the gasket either direction to remove. The door does not need to be separated on plastic inner doors.

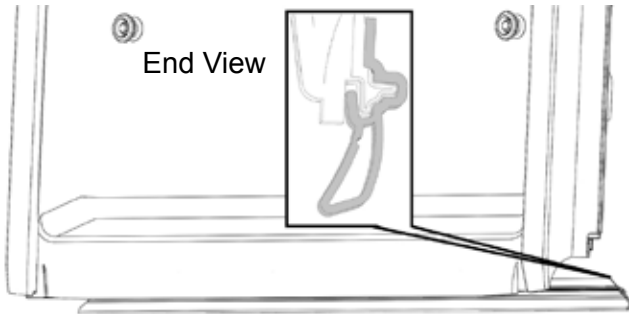

4. On stainless steel inner door (hybrid) models, the inner door panel has the door gasket riveted to the panel. The inner door panel must be replaced to replace the door gasket.

Vent Parts (On Some Models)

Front Control Models

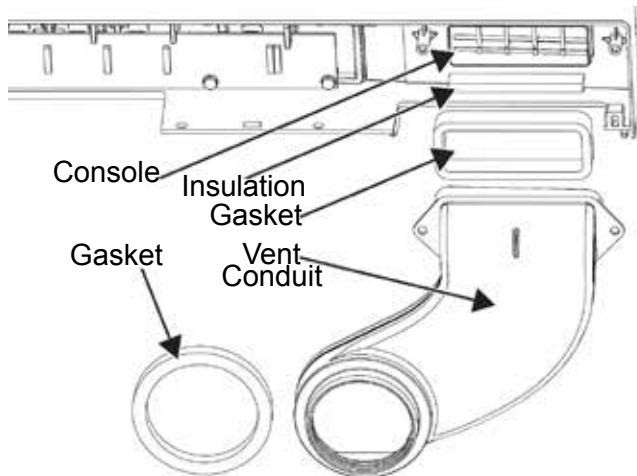

Top Control Models

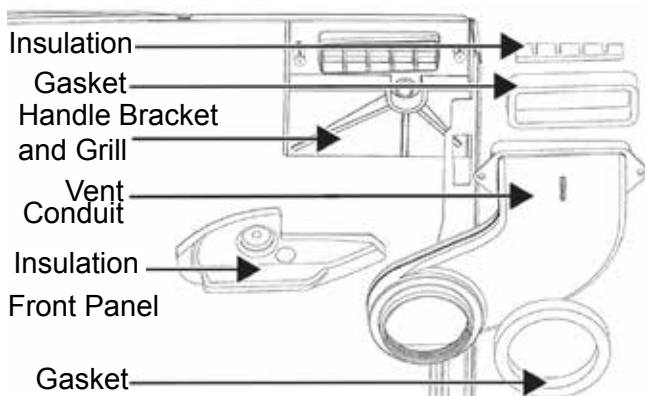

Detergent Dispenser

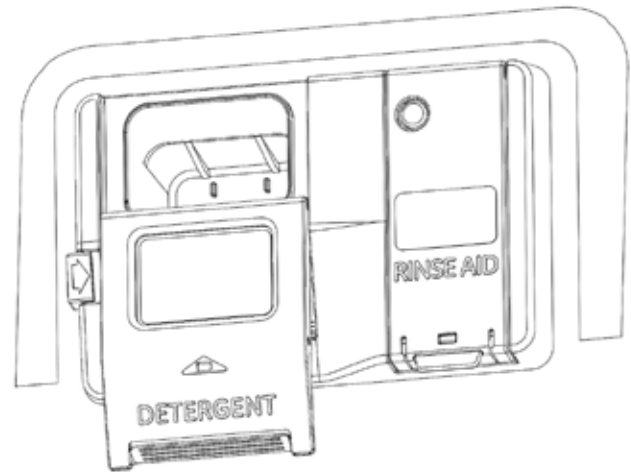

The detergent dispenser is solenoid operated, using 13.5 VDC to activate the solenoid.

Some models have a rinse agent dispenser. The dispenser holds 3.5 oz. (100 ml.) of rinse agent. Under normal conditions, this will last approximately one month.

The module receives 13.5 VDC for .5-seconds to activate the detergent cup. To activate the rinse aid, the module receives 13.5 VDC for a period of 15-seconds.

To Diagnose the Detergent Module

1. Remove power to dishwasher.
2. Remove toe kick panel.
3. Disconnect door harness.
4. Remove and separate the door.
5. The inner panel may be set into the dishwasher and latched in the closed position.
6. Reapply power.
7. Place the dishwasher into Service Mode (see **Service Mode** under the **Electronic Controls** section in this service guide), then activate the detergent test to check for 13.5 VDC to the detergent module. Service Mode will provide a 15-second activation time.

Detergent Dispenser Removal

1. Remove power to the dishwasher.
2. Remove and separate the door.

(Continued next page)

3. Remove the EPS cover, double back tape is used to secure and is reusable (when reinstalling the EPS cover, UP must be toward the top of the door).

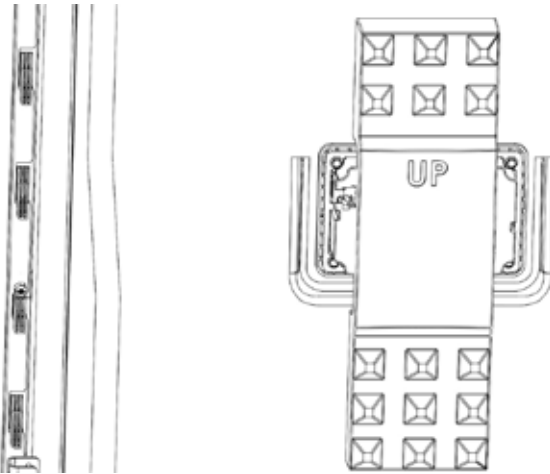

4. Remove six 1/4-inch hex-head screws.

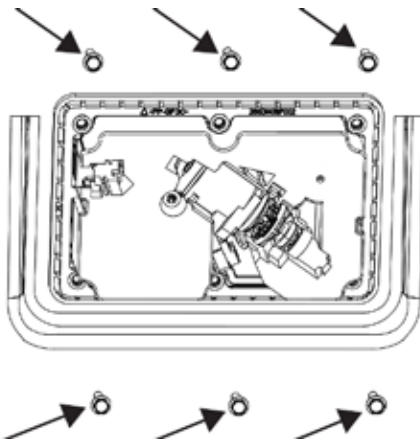

5. Mounting plate removes from inside the door.

6. The detergent module can now be removed from the inner door panel.

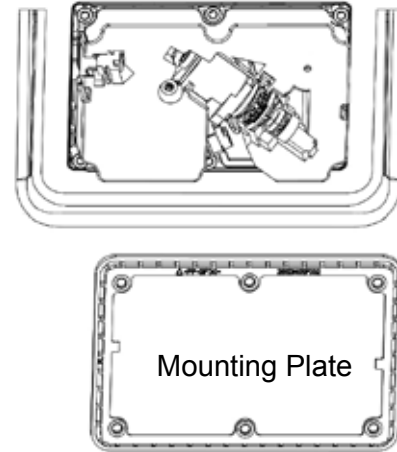

Door Strike

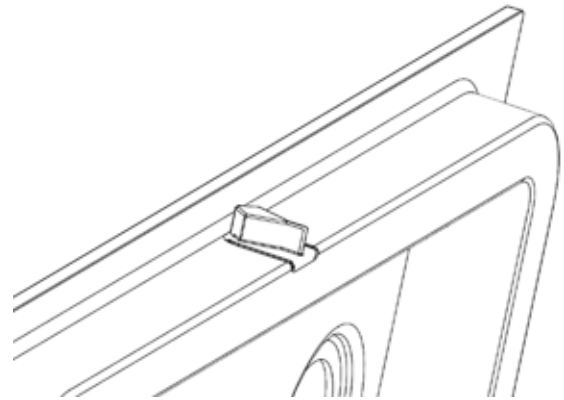

The door strike is attached to the inner door panel.

Door Strike Removal

1. Remove and separate the door.
2. Remove the control console or control panel.
3. Remove the pocket handle (on front control models only).

- Remove the 1/4-inch screw holding the strike (a Phillips-head screw will come with the service part for easier installation).

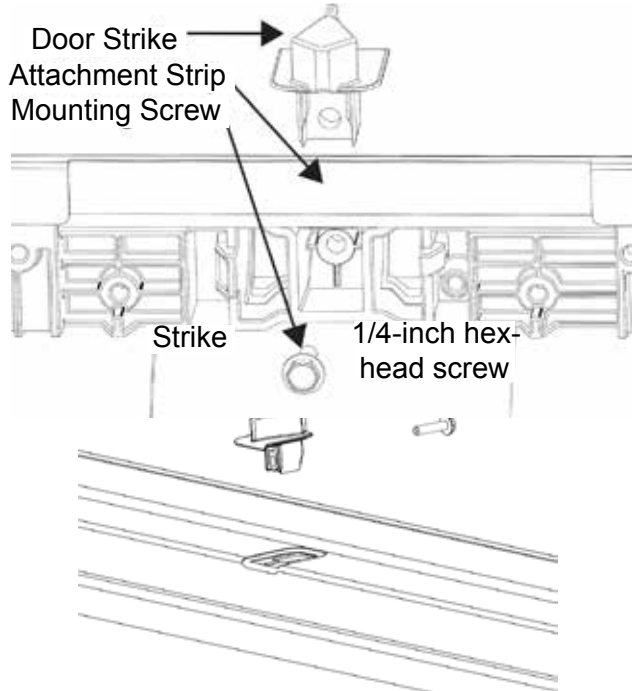

- Hybrid or stainless steel (SS) inner door models have a feature molded in the top attachment strip which secures the strike to the door.

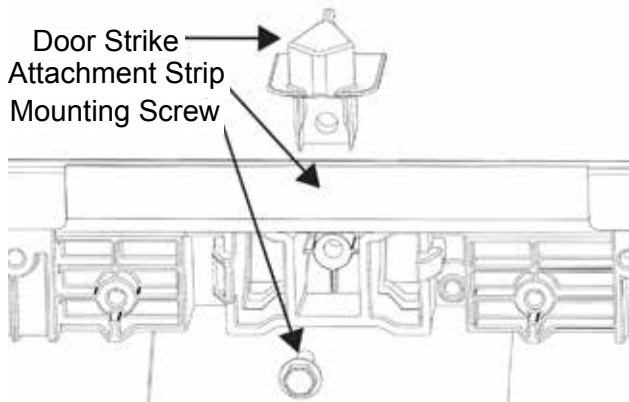

Hinge Receivers and Cross Brace (Some Models)

Stainless steel inner door models have a cross brace connecting the hinge receivers. This brace acts as a door stiffener.

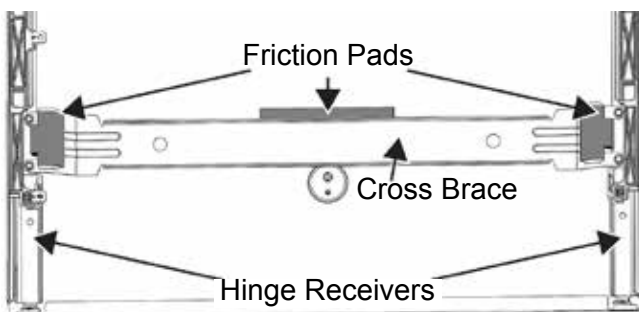

Sump Module

Appearances may vary throughout this service guide. Some models do not have all features shown or may be different depending the model number.

The Ultra-Fine Filter is a twist lock design and consumer cleanable. To remove, turn counter-clockwise (CCW).

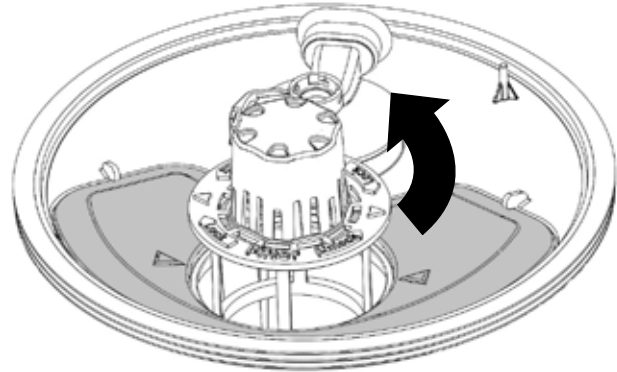

The fine filter is secured by the ultra-fine filter and two tabs. To remove, remove the ultra-fine filter and lift up on the front, allowing the back to slide out of the tabs.

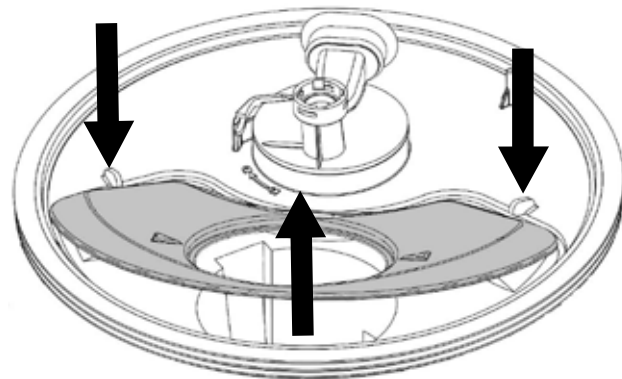

Also located on the top side of the sump are the diverter components. The bottom of the diverter is molded into the sump. A check ball or two-port diverter and a pressure diverter are used in these models. The pressure diverter may use three or four ports controlling the reversing spray arm on some models and silverware wash on some models. Full details on both diverters are found in the circulation section of this service guide.

(Continued next page)

Two-Port Diverter

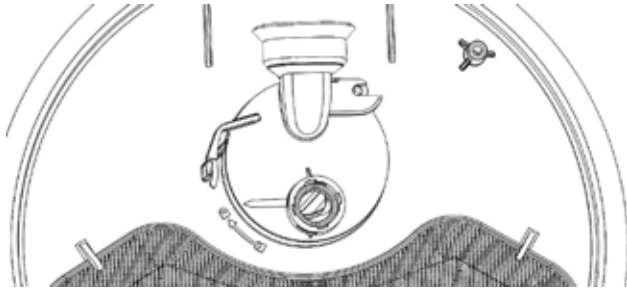

Components on the bottom of the sump include a pressure sensor, turbidity sensor, drain pump, circulation pump and some models have a diverter location switch.

The sump module is front serviceable with the dishwasher remaining in the installed location by removing the door for easier access. This section of the guide only covers the sump removal. Components and diagnostics of the sump module may be found in the **Fill System**, **Circulation System** or **Drain System** sections of this service guide.

The shaded portions indicated molded sump.

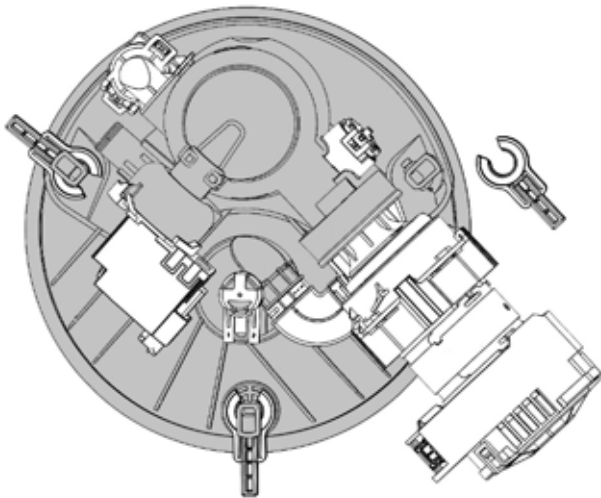

Sump Latch Cams

Sump latch cams twist and lock the sump into place; they are cammed for easy removal. The below illustrations show rotation and the stops built into the sump. The top of the illustration represents sump position as located to the front of the dishwasher.

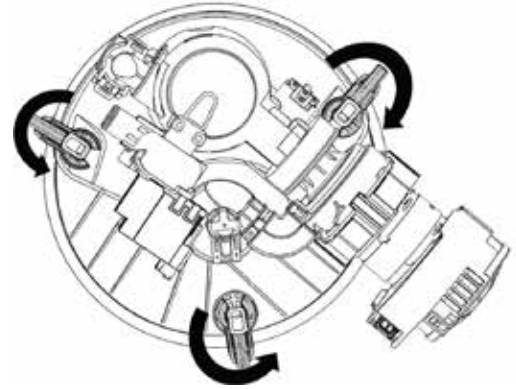

This image is the rear latch cam.

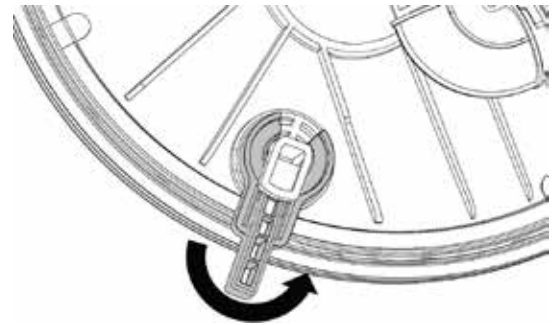

The below illustration shows the cam rotated to remove the sump. The arrow is pointing to the stop feature molded into the sump.

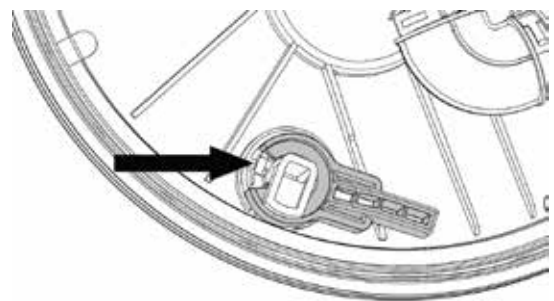

With the cam in the unlatched position and the lock tab exposed, the cam can be removed or replaced as needed by sliding it away from the post.

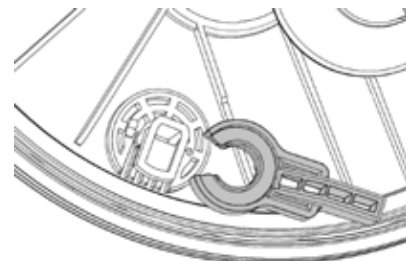

Sump Module Removal

1. Remove power to the dishwasher.
2. Remove the upper and lower racks.
3. Remove the toe kick.
4. Remove the door (see **Door Removal**, under **Door**, in the **Tub and Structure** section of this service guide).
5. Remove the lower spray arm by turning the locking nut counter-clockwise (CCW).

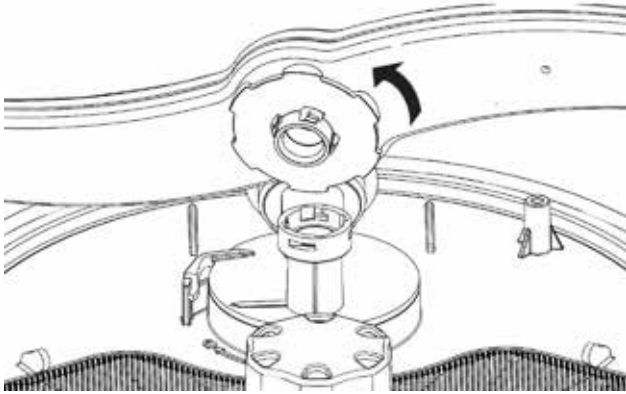

6. Remove the ultra-fine filter and fine filter by turning counter-clockwise (CCW) to remove.

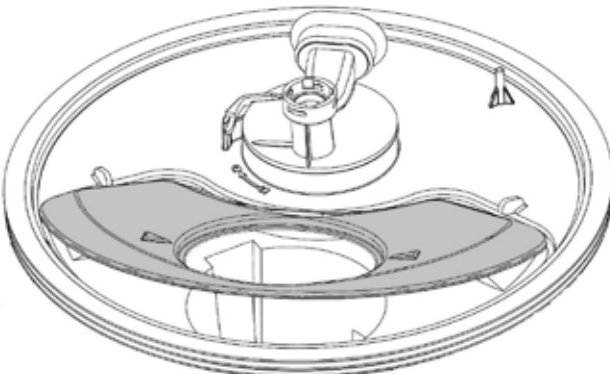
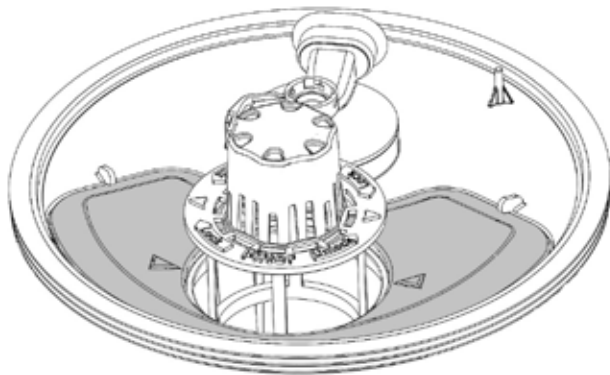

7. Remove the main conduit (see the **Circulation System** section of this service guide).
8. Loosen the high drain loop hose clamp (1/4-in. hex-head) and remove the hose from the drain pump (there will be a small amount of water in the sump, pump and hose).

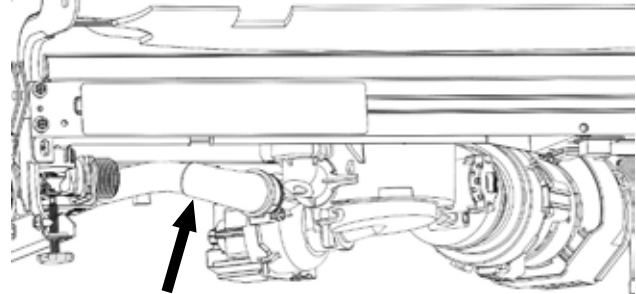

High Drain Loop Hose

9. Disconnect the turbidity sensor harness (some models).

Disconnect Turbidity Sensor Harness

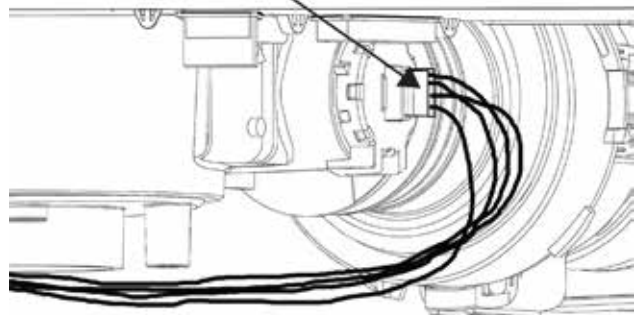

10. Remove the pressure sensor (refer to the pressure sensor portion of the fill section of this guide).

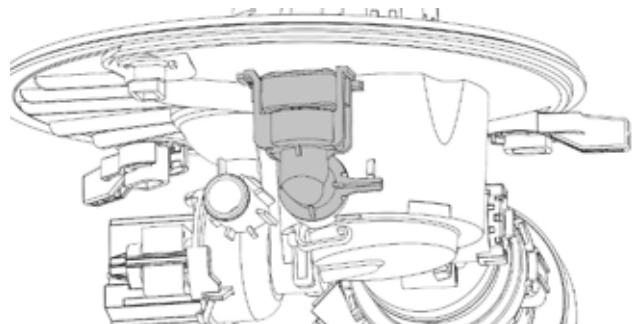

11. Unlatch three sump latches. All three latches can be reached from the front of the dishwasher in most installations. If the dishwasher does not have the legs extended; the dishwasher may have to be removed from its installed position.

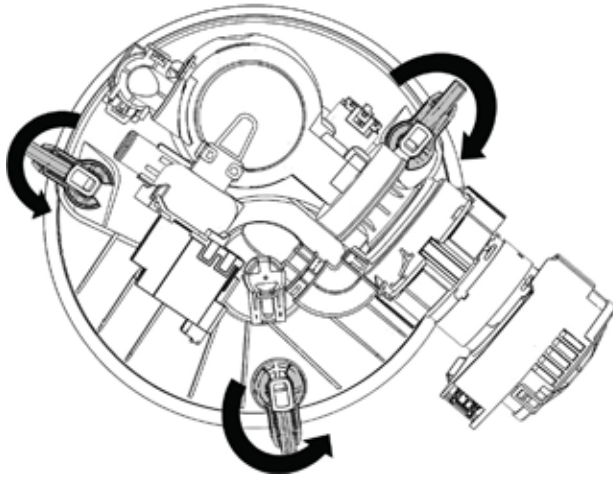

12. Push the sump from the bottom into the tub.

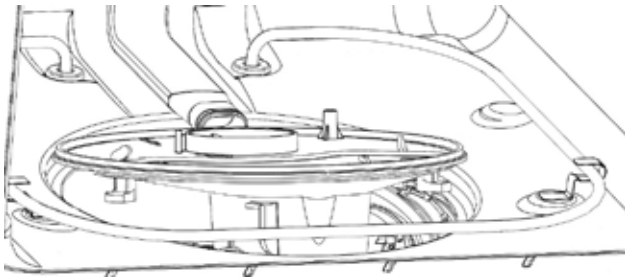

13. Grasp the sump from inside. Use care, tilt and lift to bring the sump into the tub. Bring the drain pump up and in first. This allows access to disconnect the wiring in the next step.

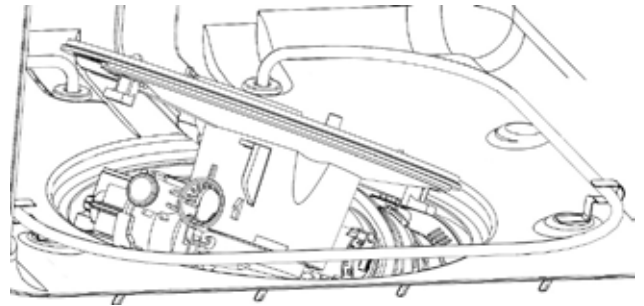

NOTE: It is important to route the wire harnesses in the same locations to prevent future damage to the harness.

14. Disconnect the circulation pump wiring, drain pump wiring and flood switch wiring.

Appearances may vary throughout this service guide. Some models do not have all features shown or may be different depending the model number.

Sump Gasket

Stressing or softening the gasket ribs (pressing the ribs against a hard surface, see below) will make a new gasket seat easier. Lubricating with a small amount of rinse agent or water will also ease installation.



Installing Sump Module

While inserting the sump assembly back into the tub, use care to ensure the sump assembly wiring and components are not pinched between the sump and the tub.

NOTE: Using rinse aid or water on the sump gasket will aid sump installation.

1. Reconnect wiring to the pumps and flood switch. Do not connect the turbidity sensor until after the sump module is back in place (step 5) to prevent damage to the connector.
2. Align the main conduit connection out of the diverter on the sump module to the rear of the tub and main conduit
3. Press firmly into place, using both hands to push down on the sump module.

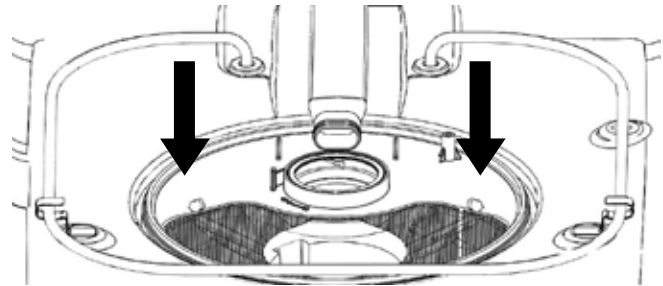

4. Latch the three sump latch cams. The latch cams must not be used to pull the sump module into place.
5. Connect the turbidity sensor and high drain loop hose.

Electronic Controls

The main control board is located under the dishwasher. It is supplied 120 VAC from the consumer's home. Outputs include 120-volt AC to the heating element, wash and drain motors. The control also supplies 13.5 VDC to the fill system, door switches, turbidity sensor (some models), user interface (UI) board and detergent module in the door.

The main control has a **CSM** (Current Sense Module) located on the control. If the CSM detects a ground path, the dishwasher will be non-responsive, all control panel LED's will be flashing, and models with a display will show 888 .

CSM (Current Sense Module) Introduction

A CSM is a protective device that is located on the main control of GEA Dishwashers. This device is designed to trip if current leakage to ground is above 20mA ± 5mA if detected. The CSM functions similar to commercially available GFCI's; if tripped, the dishwasher will be non-responsive.

The CSM may be reset by the consumer by cycling the house electrical supply to the dishwasher.

NOTE: The dishwasher MUST be grounded and never operated without a ground connection.

Error Mode

To Enter Error Mode

With the dishwasher in Standby Mode (not running a cycle), press and hold the furthest most pad on the left and Start buttons simultaneously for 5-seconds.

On entry into the Error Mode, the control reports the door status for 10-seconds.

- All LED's are solidly illuminated if the door is detected as closed.
- All LED's are flashing if the door is detected as open.

After the door check, the control will enter a mode to display any fault codes that are currently detected by the control.

Start LED Blinks	Fault Code	Fault Description
2	F153	Door latch failure.
3	F50	Temperature sensor high.
4	F51	Temperature sensor low.
5	F53	Fuse failure with circulation pump on.
6	F56	Failure to drain.
7	F97	Absent heat source.
8	F112/ F155	Key stuck.
9	F99	Minimum wash temperature not met.

If start LED blinks, it indicates the fault condition is present. These fault displays cannot be cleared manually; they will be automatically cleared by the control when the fault condition is no longer present.

Error Mode will time out after 5-minutes.

ANY KEY PRESSES OTHER THAN CYCLE SELECT EXIT THIS MODE.

Fault Codes

Fault Code	Load to Control	Timeout / Notes
F1	Communication Error with User Interface (UI) Board	Verify harness connections between user interface (UI) board and main control (MC) Board.
F16	High Water Temperature	Check thermistor, harness, and connectors.
F32	Water Level Sensor Invalid	Check to see if pressure sensor is plugged in. If so, then most likely pressure sensor is out of range, thus replace pressure sensor. If this doesn't work, most likely the wire harness has a short somewhere.
F33	Low Pressure Sensor Reading	Check harness on pressure sensor and make sure it is plugged in. If not, replace the pressure sensor.
F34	Leak Detected	Leak Detected. Check for water leak, repair as needed. Once leak is repaired, drain water in pan, dry sensor.
F36	CSM Tripped (CSM Lock Out)	Entering Circulate Test or Heater Test will reset the CSM. Always check the following before replacing the main control. Inspect exposed heater (some models) for splits, cracks, or zippering; replace if needed. Fill and run Circulate Test several times to look for leaks. Run Heater Test and drain.
F37	Diverter Feedback Error	Check that diverter sensor plug (red) is properly connected to the diverter. Check water level: if low, correct water level issue. Use clear door, run "Operate Loads – Circulation Pump Test"*. If position never changes when selecting each wash area, then replace the diverter. If position changes every 5- to 15-seconds when selecting a single wash area, replace the diverter and DC harness. *Diverter may cycle up to three times before finding its selected wash area.
F48	Turbidity Sensor High	Not used. Ignore fault.
F49	Turbidity Sensor Low	Not used. Ignore fault.
F50	Temperature Sensor High	Check thermistor, wiring and connections.
F51	Temperature Sensor Low	Check thermistor, wiring and connections.
F52	Turbidity Sensor Calibration Fail	Check for harness and connections problems to turbidity sensor. Replace turbidity sensor.
F53	Circulating Pump Failure	Circulation Pump Failure. Replace circulation pump and replaceable fuse located on main control board.
F54	Drain Pump Failure	Replace drain pump and replaceable fuse located on main control board.
F55	Blown Pump Fuse on Main Control Board	Replace fuse in fuse holder located on main control board. In Service Mode, operate the circulation pump and then drain pump to test. If fuse blows again when testing either pump, replace the faulty pump.
F56	Failure to Drain	Review TB12-20
F58	Dry Heater Thermistor Error: Out of Range High	Check that thermistor harness is plugged in. Check that terminals are not bent inside connector housing.

(Continued next page)

Fault Code	Load to Control	Timeout / Notes
F59	Dry Heater Thermistor Error: Out of Range Low	Check that thermistor harness is plugged in. Check that terminals are not bent inside connector housing.
F60	Heater Relay Stuck On Fault	Clear faults and cycle power to unit. If fault reoccurs within 60-seconds of power up, replace main control board.
F61	CSM Check Failed	Cycle power and start cycle to clear fault. If fault does not clear, replace main control.
F62	Dry Heater Fan Error	Check dry heater fan operation and verify speed is greater than 2,500 RPM. Check that the dry heater fan harness is plugged in.
F63	Flood Condition Fault	The pressure sensor has detected the water level above the flood limit. Check the water valve for a stuck open valve (continuous fill into the tub). Run the Fill Test under the Diagnostics Test tab and ensure the pressure sensor is in the range of 40.77 and 40.44 Hz. Check that the fill funnel or door vent conduit at the bottom of the door is not obstructed or blocked. This can cause a pressure build up in the tub as the unit heats during a cycle.
F64	Ignore Fault	Ignore fault.
F66	Dry Heater Fault	Check harness, may need to replace dry heater.
F86	No Fill Failure	Check water valve, see if a water source is hooked up to the dishwasher.
F87	Dry Heater Diagnostic Fault	Possibly any error with dry heater/relay/fan.
F96	Ignore Fault	Ignore fault.
F97	Absent Heat Source	Verify proper water level. Check heater. Check thermistor. Check main control.
F98	Non-Draining Sump (Turbidity Based)	Verify proper drain pump operation, restrictions, and installation.
F99	Minimum Wash Temp Not Met	Verify proper water level (no water will trip thermal cut off, or TCO). Check heater TCO (replace TCO and harness if tripped). Check heater. Check thermistor. Check main control.
F112	Key Stuck	<p>Push-button Models: Check button operation, each button should "click". Check for plastic flash. Replace user interface (UI) board.</p> <p>Capacitive Touch Models: Inactive F112's can indicate inadvertent button contact, controls in Delay Start or Control Lock mode, and consumer education. Check that each key operates, each button should "beep" and light up once pressed. If a key doesn't respond, replace user interface (UI).</p>
F128	Low Rinse Aid	Low rinse aid detected.

Critical Faults

Start LED Blinks	SSD* Display	Error Name	Timeout / Notes
2	Adc or Hrf	Internal Board Failure	Replace machine control board. Power cycle to exit.
4	CFE	Continuous Fill Error	Check for a stuck open water valve by disconnecting power to the dishwasher. Check to see if water valve is getting continuous voltage.
5	Ftd	Failure to Drain	Check for clog in air gap/disposer, drain hoses, and drain pump. Check that disposer plug has been removed. Check drain hose routing to match Install Instructions.
6	H2O	Water Supply Failure	Verify the water supply line is connected properly, the supply line valve is turned on, and restart the cycle.
7	AcF	High Supply Voltage	Check the supply voltage. Supply voltage is greater than 170V.
8	dLF	Door Latch Failure	Check continuity of the harness. With the door closed there should be continuity through all three pins of the door latch. Replace door latch if no problems are found with the harness.
9	PrS	Pressure Sensor Failure	Verify pressure sensor harness has continuity. Unplug/plug harness at board and pressure sensor. Replace pressure sensor if needed.
10	FuS	Board Circulation Pump Fuse Failure	Check the continuity on the circulation pump fuse. Check the circulation pump motor. See, Failure to Drain Diagnostics AND No Circulation and Drain section for details.

*SSD: Seven Segment Display

Service Mode

Entering Service Mode

NOTE: Entering Service Mode resets the CSM.

The dishwasher must be in Error Mode to enter Service Mode. Entering Service Mode will reset the CSM, allowing loads to be checked for the cause of the CSM to trip. The control will blink the Normal LED (light on model GDF510PxJxx) every few seconds for the number of times corresponding to the load being tested.

While in Error Mode

- Press and hold Cycle Select pad for 5-seconds.
- Press Cycle Select.
- Press Cycle Select to select or increment each test.
- Press Start, to start and stop each test.

LED Blink #	Load to Control	Timeout / Notes
1	Drain Pump	Attempts to automatically empty tub. Takes approximately 75 seconds from normal level.
2	Water Valve	Attempts to fill to normal level. Takes approximately 1 minute.
3	Circulation Pump	Runs for approximately 2 minutes, alternating lower spray arm to mid and upper spray systems every 30 seconds.
4	Heater	Turns on heater for a maximum of 2 minutes.
5	Detergent Module	Turns on detergent module solenoid for a maximum of 2 minutes.
6 (Some Models)	Dry Fan	Turns on fan assembly for a maximum of 2 minutes.

Service Mode will exit after 5-minutes of inactivity.

Exit Service Mode by pressing and holding Cycle Select and Start pads for 5 seconds.

Diagnosing Electronic Control Boards

Diagnosing the main control and user interface (UI) control are covered in this section. Many components can be checked from the main control, which can be accessed with the door on or removed if needed. Some connectors are located through the bottom cover to allow easy access to AC supply connector, door harness and **ACM** or **A**ppliance **C**ontrol **M**odule. The ACM or smart appliance allows the appliance to communicate with the utility meter when peak rates occur, and allows the appliance to respond and operate in a manner that will reduce energy usage of that appliance at high/critical demand rates. For more on the module and display, refer to the separate smart appliance documents.

WARNING: GEA Factory Service Technicians are REQUIRED to follow Lockout / Tagout (LOTO) 6 Step Process prior to beginning repair.

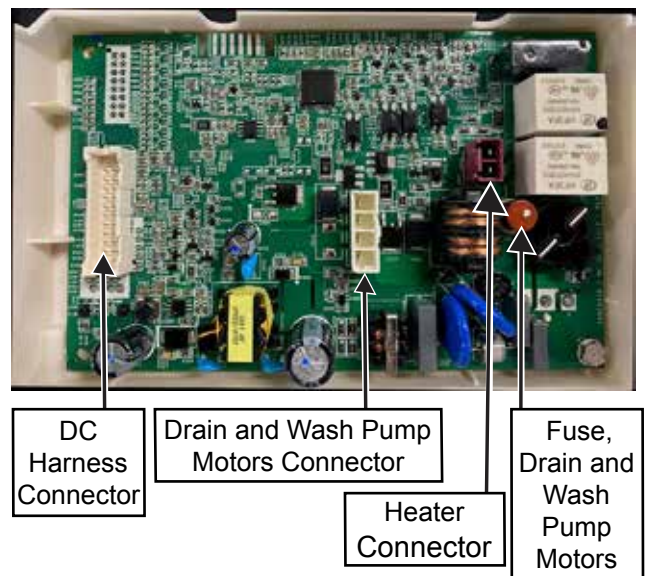

Main Control Diagnostics

The service LED has a continuous flash which only advises the main control has power. The service LED no longer has any blink patterns which were used to aid diagnostic in the past.

On the Main Control Board CSM

A CSM is a protective device located on the main control board. This device is designed to trip if current leakage to ground is above $20\text{mA} \pm 5\text{mA}$ is detected. The CSM functions similar to commercially available GFCI's. If tripped, the dishwasher is non-responsive and all the LED's will flash until the CSM is reset. Entering **Error Mode** will allow the door status check with LED's flashing for 10-seconds with the door open or on solid for 10-seconds, if the door is closed. If there are active error codes logged, they will be displayed at this time. Specific errors are displayed with LED's. Other error codes may assist with diagnosing (see **Error Mode**, in this section). The CSM is reset when **Service Mode** is entered.

Cycling power to the dishwasher will also reset the CSM, allowing consumers to reset without a service call. If the CSM re-trips, they should call for service to diagnose and repair the cause of the tripping condition.

The cause of tripping is likely external to the board itself. The board should only be replaced after all other diagnostic tests have been completed and all other potential causes have been ruled out. Potential causes of current leakage to ground could be due to water leaking onto a live component, a component malfunction, or a fault within the wiring harness. If water caused the CSM to trip, the leak must be repaired. The dishwasher may run until a leak causes the trip to reoccur. Resetting the CSM without fixing the underlying issue, will likely result in a repeat call. Always perform a visual inspection of the exposed heating element, looking specifically for cracks, splits, or swelling of the sheath.

CSM Diagnostics

NOTE: Normal water level must be present when checking the circulation pump, drain pump, and the heater.

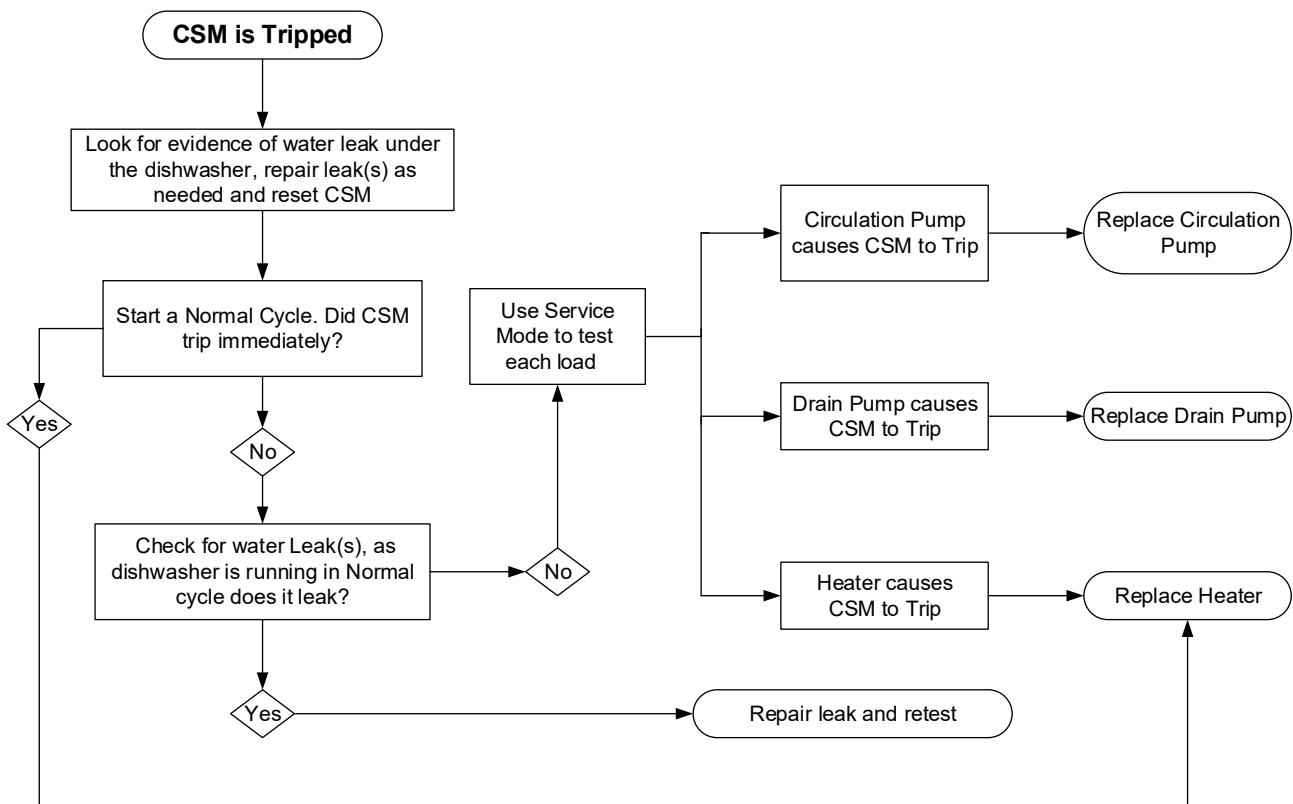

Top Side of Main Control

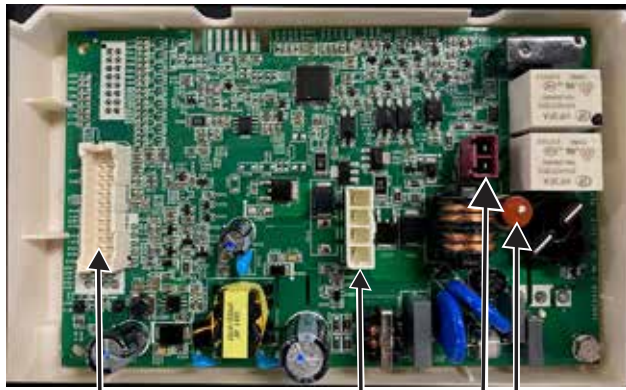

DC
Harness
Connector

Drain and Wash Pump
Motors Connector

Heater
Connector

Fuse,
Drain and
Wash
Pump
Motors

WARNING: GEA Factory Service Technicians are REQUIRED to follow Lockout / Tagout (LOTO) 6 Step Process prior to beginning repair.

To Access Main Control Board:

1. Remove power to the dishwasher.
2. Remove the toe kick panel.
3. Remove the door (optional).
4. Remove the junction box cover.
5. Remove the 1/4-inch hex-head screw on control box

Remove the 1/4-in. hex-head screw

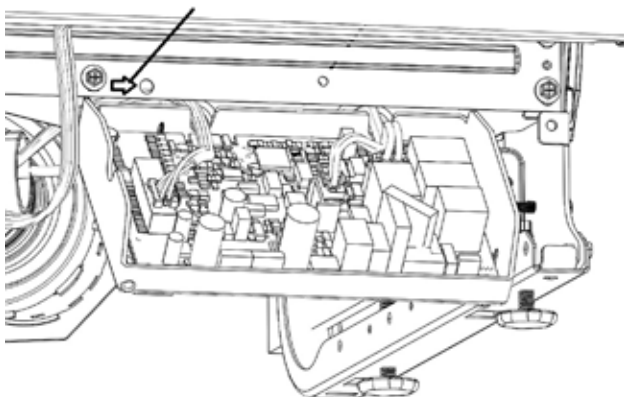

6. Pull down on the bottom cover at the front of the control box. While pulling down on the front of the bottom cover, slide the cover forward to clear the back lip and junction box bracket.

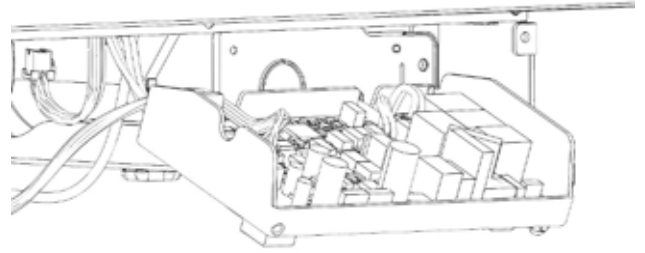

7. Pull cover and control forward, taking care not to damage the board or the wiring.
8. To remove the control board from the bottom cover, remove the ground screw and release the standoffs.
9. Use care when reinstalling the main control board to prevent wire pinching. Make sure the harnesses are routed properly, through the access ports in the control area and above the sump hoses to keep them from snagging on the floor.

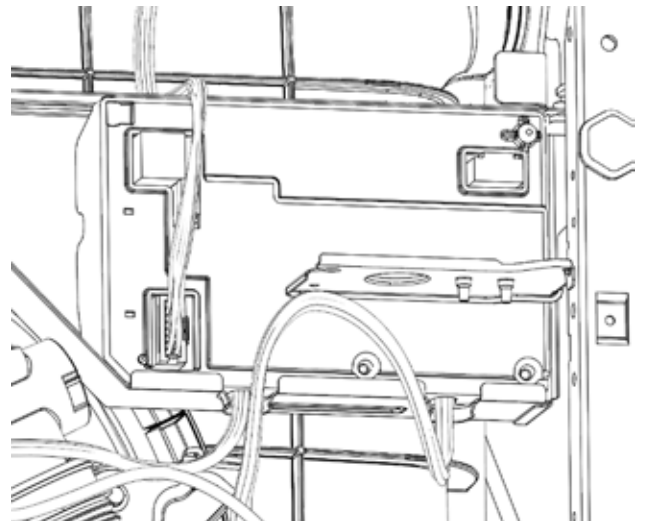

10. All ground screws must be reinstalled.

User Interface (UI) Diagnostics

No display or LED's will light (excluding model GDF510).

1. Check for 120 VAC entering the main control.
If no volts are found, check the home breaker.
2. Attempt to enter Error Mode. If LED's light, the CSM is tripped. Consult **On the Main Control Board CSM** section of this service guide to diagnose and repair.
3. Check the door harness connections.

Fill System

The dishwasher has a fill volume of approximately .83 gallons of water and is a DC volt circuit. The water valve is rated at 13.5 VDC, resistance is 32-ohms and has a flow rate of .83 GPM. The fill time is 1-minute. The water valve is located in the front left corner, under the dishwasher.

Components

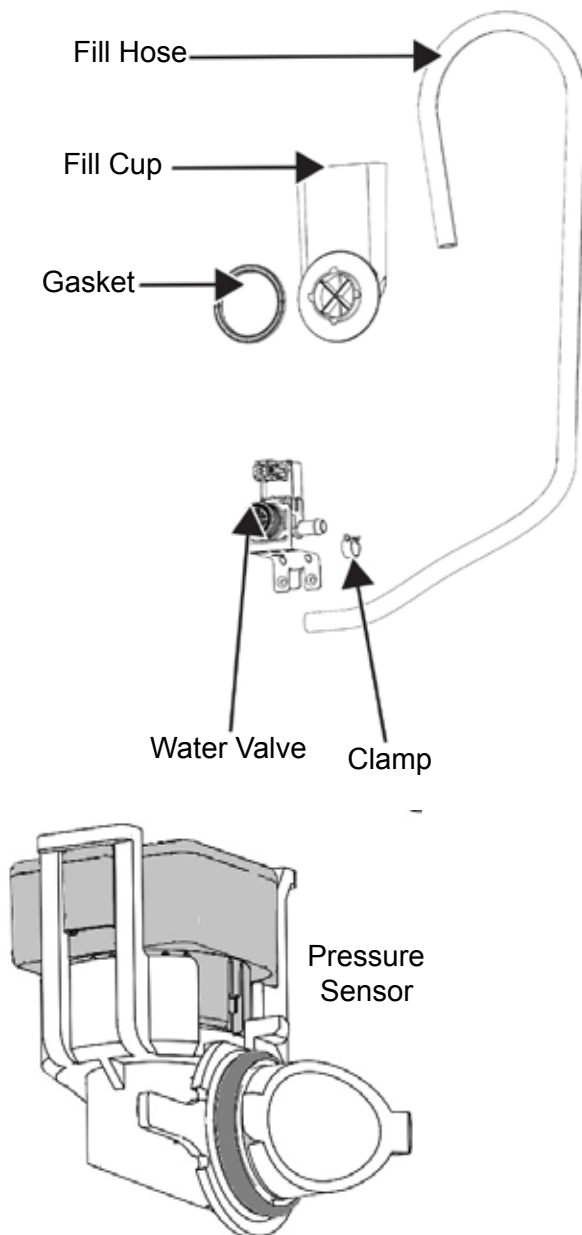

Water Level

To check for proper water level, place the dishwasher in Service Mode and run the Fill Test (see **Service Mode** in the **Electronic Controls** section in this service guide). Water must reach the level shown below.



Pressure Sensor

A pressure sensor is used to monitor water level. The switch provides feedback to the control. The pressure sensor is located on the front of the sump.

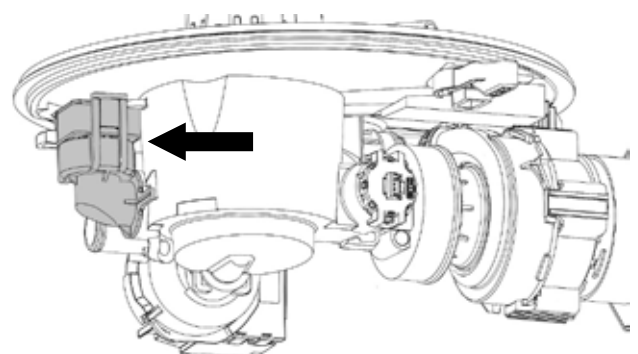

Testing the Pressure Sensor: To verify the pressure sensor is receiving power, remove the connector from the sensor and test for 5 VDC between pin 2 (+) and pin 3 (-) on the sensor. To verify the sensor is properly sending the water level signal to the machine control, test for voltage (0 to 5 VDC) between pin 7 (+) and pin 12 (-) on the machine control connector J806. Use the chart on the next page to determine if the output frequency corresponds to the water level observed inside the dishwasher.

NOTE: When flood trip point is reached (40.11 to 39.69 Hz), the drain pump will turn on.

Pressure Sensor Removal

1. Remove power to the dishwasher.
2. Remove the toe kick.
3. Carefully pull the locking tab toward the body and turn the pressure sensor counter-clockwise (CCW) while pulling the switch out.

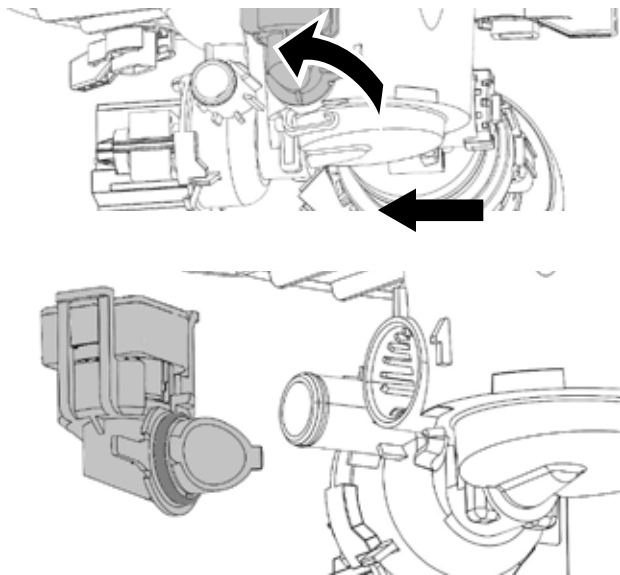

4. Remove the harness from the sensor.

No Fill Diagnostics

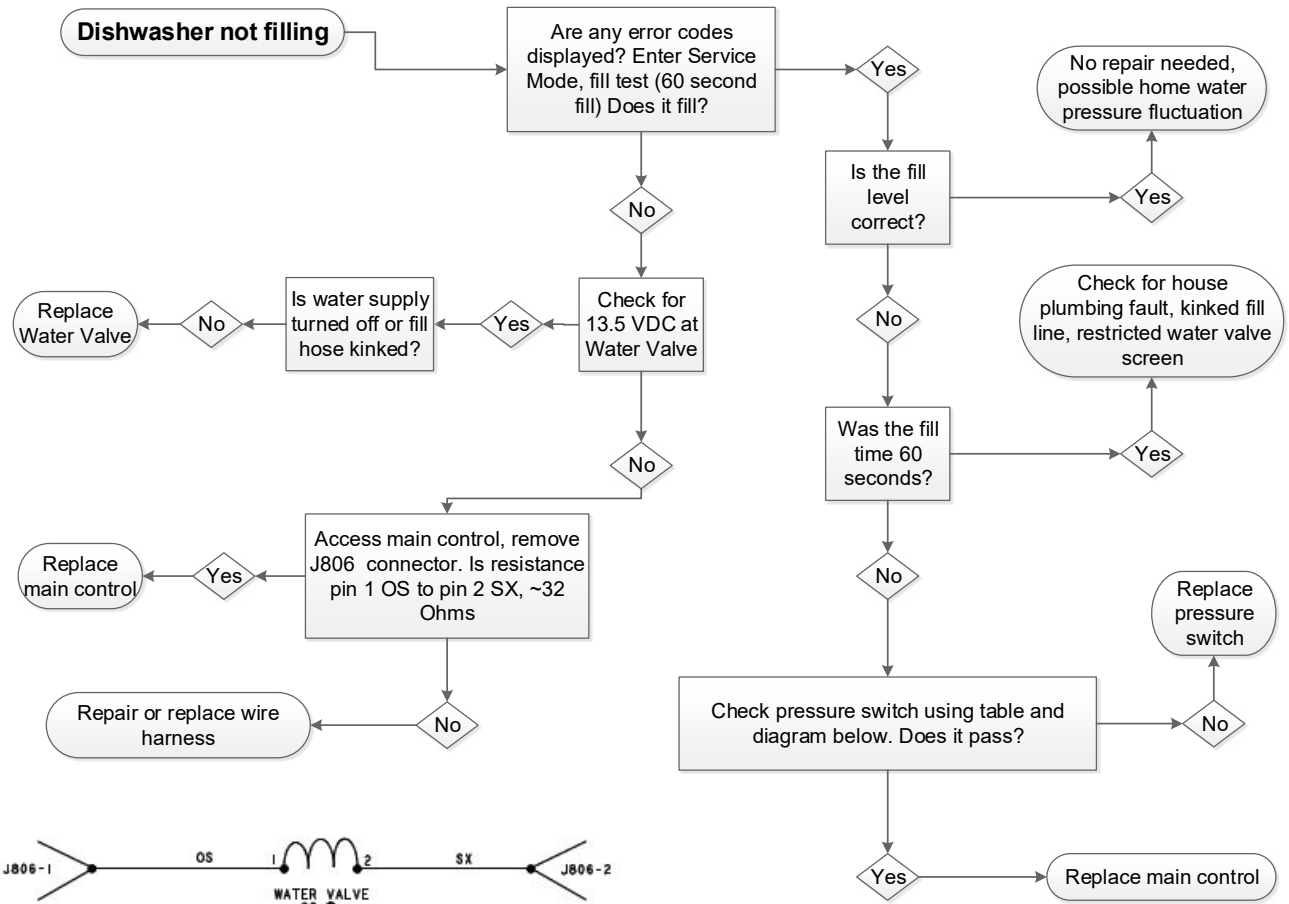

Internal Water Height (mmH2O)	0 to 5 VDC Freq. Output (Hz)	Internal Water Level Description
0	44.27 to 43.94	Dry
85	40.77 to 40.44	Typical Fill
102	40.11 to 39.69	Flood Trip Point - Drain Pump Runs
115	39.61 to 39.12	Water Over Tub Lip

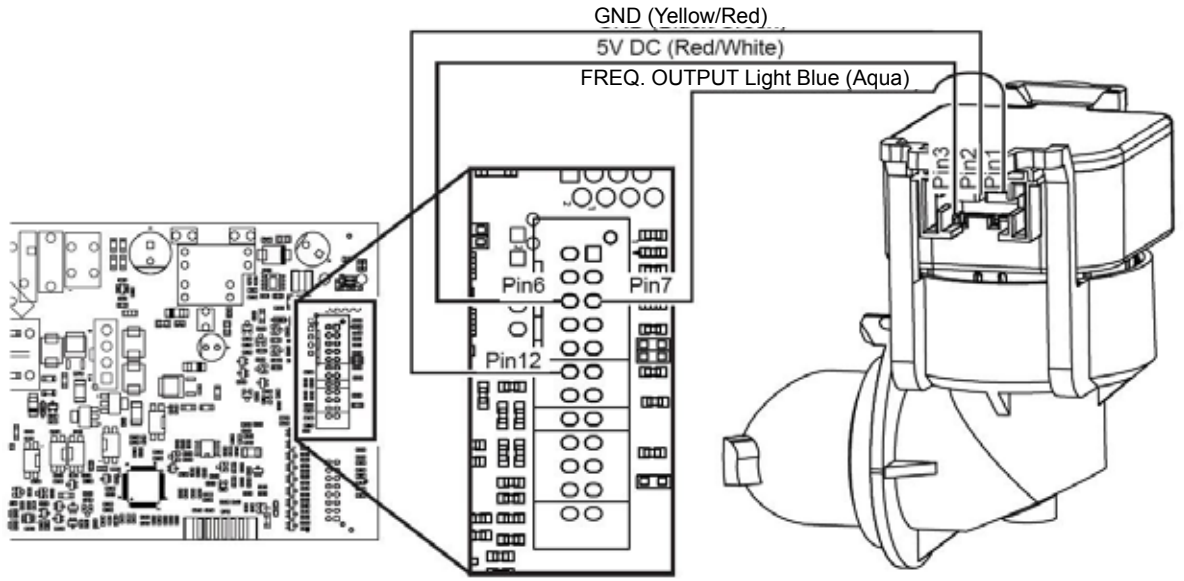

Fill Funnel and Hose

The fill funnel is located on the left side of the dishwasher tub and can be removed by turning the fill funnel counter-clockwise (CCW) (twist lock design). There is a gasket between the fill funnel and the tub. The fill hose connects the water valve to the fill funnel.

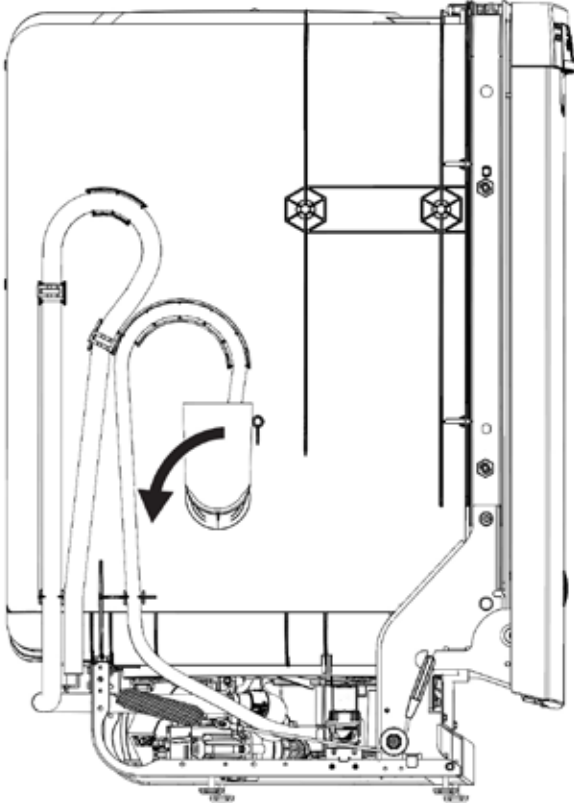

Fill Valve

1. Remove power to the dishwasher.
2. Remove the toe kick.
3. Remove two 1/4-inch hex-head screws from the bracket to the leg assembly.

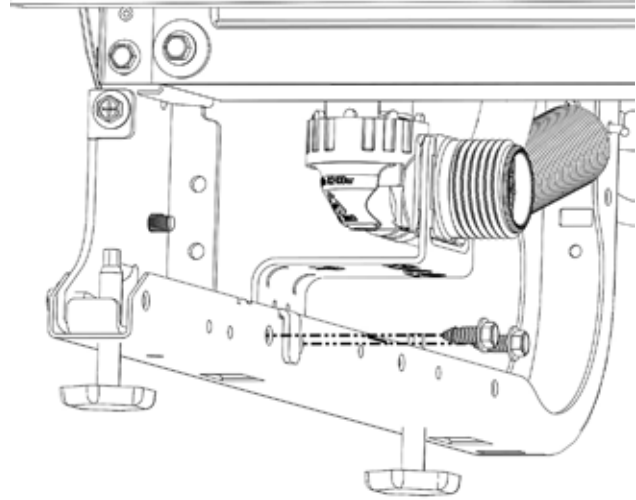

4. Slide the bracket off of the leg.
5. Remove the wire harness.
6. Remove the fill hose by using pliers to remove tension on the spring clamp.

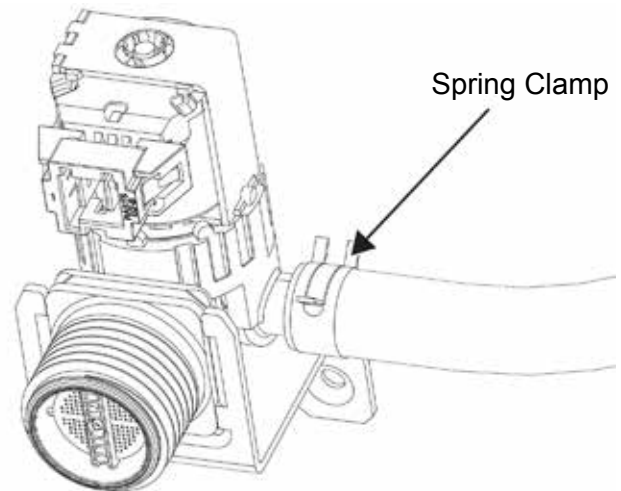

Circulation System

With only .80 to .95 gallons of water, filtration is the start of improved performance. Water is cleaned through the fine and ultra-fine filters before it enters the main pump. Water must also flow through the Piranha Hard-Food Disposal and finally into the wash pump assembly. Clean filtered water then flows into the diverter system which directs it to either the lower spray arm or mid spray arm and upper sprayer. Water is jetted through more jets and with more power due to different wash zones created by the diverter.

This section will discuss wash system filtration, operation, components, removal procedures and diagnostics. The new 2020 plastic tub dishwasher features alternating spray arms allowing low water use, helping energy efficiency. A diverter system is used to isolate the wash arms and is controlled by cycling the wash pump as described later in this section. Some models have a wash zone feature which allows the consumer the flexibility of washing in the lower or upper racks only. Using this feature will shorten the cycle time by 30%. When **Bottle Wash** is selected, the upper rack time is increased allowing the bottle wash feature to be used for maximum cleaning. Filtration has been greatly improved to allow clean filtered water to circulate during wash. The fine and ultra-fine filters are consumer removable and cleanable.

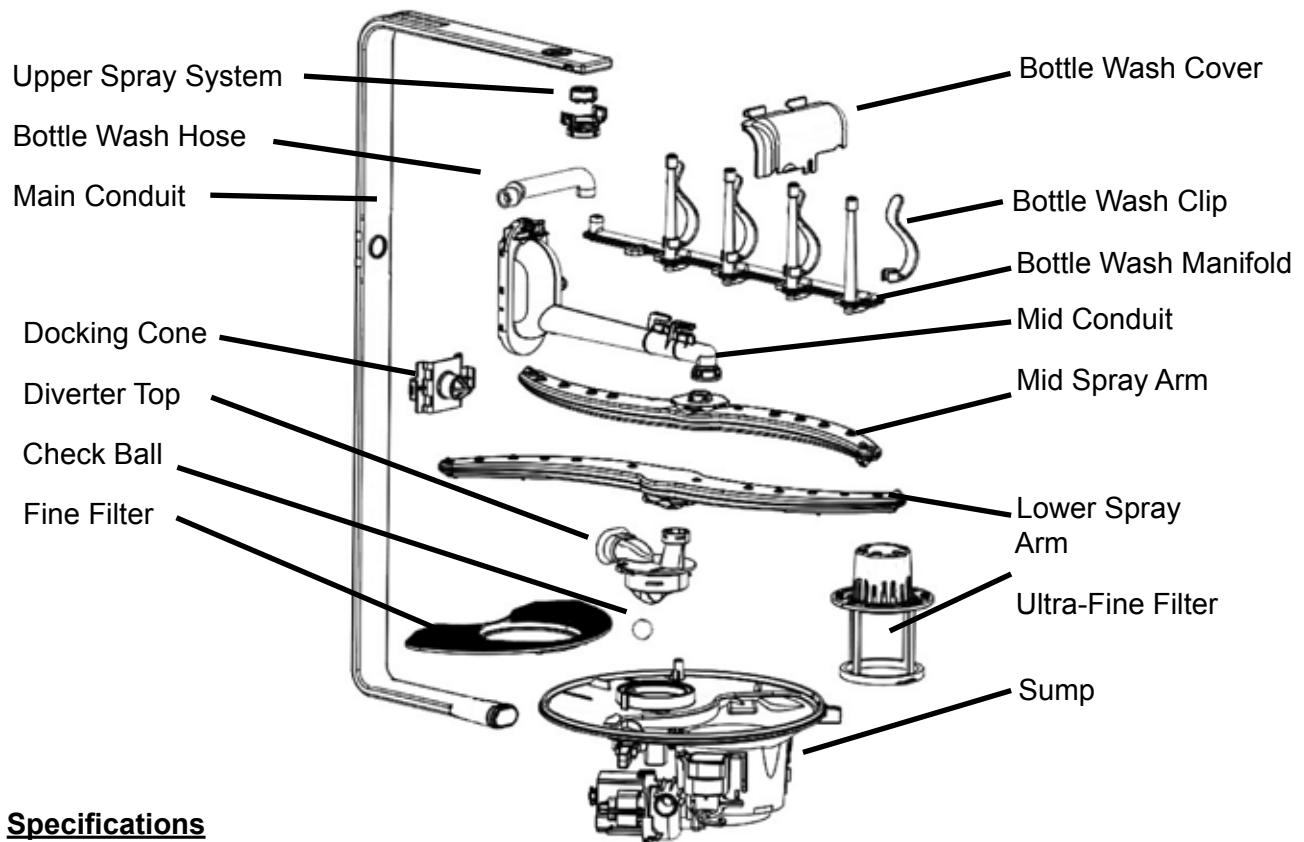

Specifications

- **Single Speed Circulation Pump:** 120 VAC, .8 amps – 3.8 LRA, 8 GPM @ 5 PSI
- **Heater:** 120 VAC, 18 ohms wet – 28.8 ohm dry, 6.67 amp wet -4.17 dry, Watts 800 wet /500 dry +/- 5%
- **Detergent Cup:** 13.5 VDC, 32 ohms, .5 second to release detergent cup, 15-seconds to release Rinse Aid (see the **Door** section of **Tub and Structure** in this service guide).

- **Turbidity Sensor:** 5 VDC to LED, 10k ohms
- **Thermistor** (in turbidity sensor)
- **Spray Arm Rotation:**

Spray Arm	RPM
Lower	50 RPM CW +/- 10%
Middle	30 RPM CCW +/- 10%

CW: Clockwise

CCW: Counter-Clockwise

Diagnostics

Clear Door Diagnostic Tool

The clear door (**Part #:** WX05X20002) provides technicians with a tool to accurately diagnose 2012 and newer dishwashers. Viewing the wash zones not only includes more accuracy, it will reduce diagnostic time, reduce repeat calls, and will increase technician confidence. There may also be situations where the clear door can be used to show a consumer the dishwasher is operating properly.

Poor wash results can be due to many different causes. The clear door allows operation and visibility of spray arms including rotation, slow or non-rotation, leaks between wash components, restrictions, and spray jet pattern.

Proper spray arm speeds have a tolerance of +/- 5 RPM. The lower spray arm turns clockwise (CW) at approximately 50 RPM. The mid spray arm turns approximately 30 RPM counter-clockwise (CCW). The upper sprayer cannot be counted but can be viewed for proper operation.

To Use WX05X20002 Clear Door

1. Place the dishwasher in Service Mode to fill, circulate and drain. Details on Error Mode and Service Mode can be found in dishwasher mini manuals and in this service guide. All models have the same entry directions. Different controls have different ways to communicate results and progress.
2. Remove the bottom rack for an unobstructed view of the lower spray arm.
3. Enter Error Mode.
4. Enter Service Mode.
5. Open the dishwasher door all the way to 90 degrees.
6. Place the WX05X20002 Clear Door into the tub opening starting at the bottom.

WARNING: To prevent any damage, do not close the dishwasher door when the clear door is in use.

7. The clear door has a latch strike. When pushed into the latched position, it will activate the door switch assembly. The dishwasher may not start if the door is installed too low.
8. Initiate Fill; the dishwasher will fill for 60-seconds.
9. Initiate the circulate test to view the circulation system in action.
10. Service mode will initiate a 2-minute circulate test 30-seconds lower clockwise (CW), 2- to 3-seconds lower counter-clockwise (CCW) (will not reach full speed unless dishwasher is in a main wash cycle) and 30-seconds upper spray system. This pattern will repeat.
11. Use a flashlight for better visibility. Look for leaks in all areas including between the conduits and wash components.
12. Determine potential areas for further inspection and diagnoses.
13. Initiate drain; the dishwasher will drain for approximately 70-seconds.
14. Remove the WX05X20002 Clear Door.
15. Proceed with any inspections, diagnoses and repairs as detailed in the **No Circulation and Drain** flow chart. Some components may cause different symptoms depending on the severity of part failure.

No Circulation and Drain

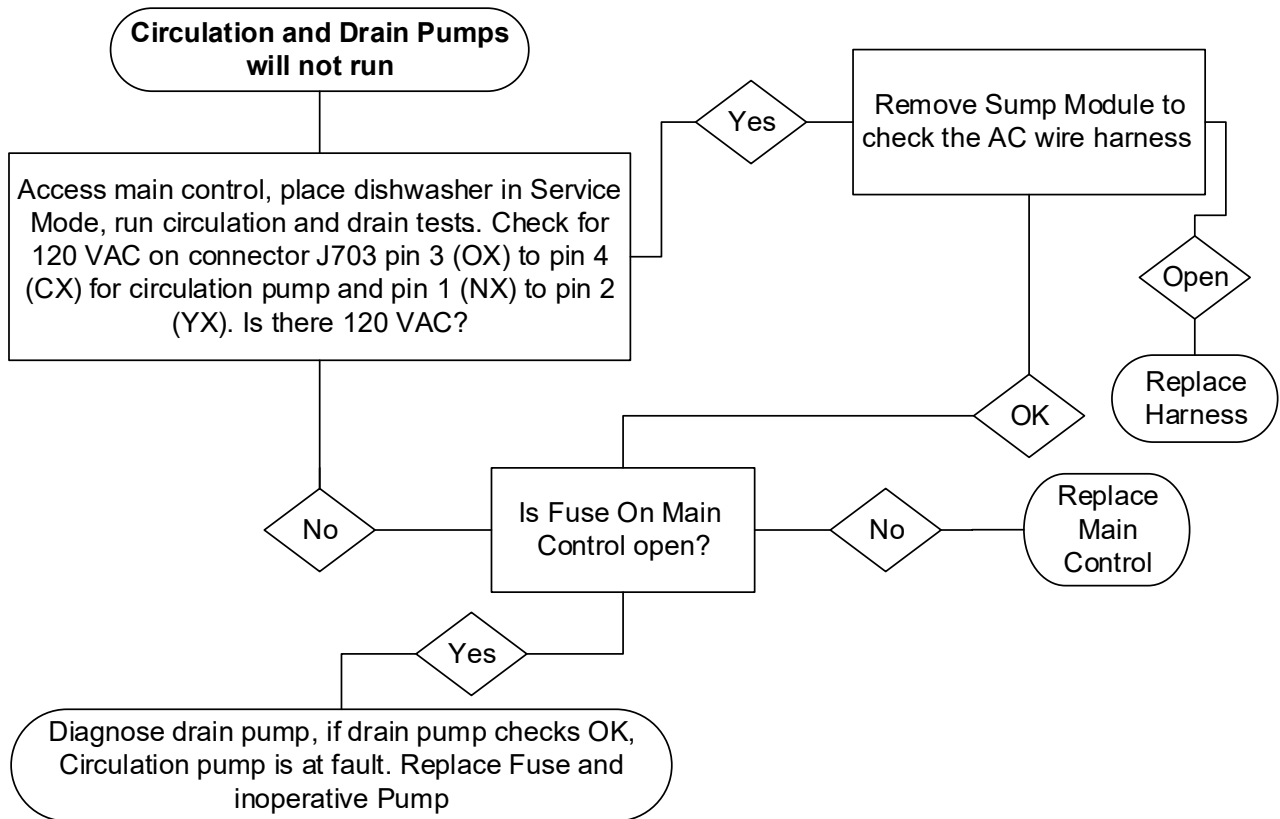

Motors Fuse

A motors fuse is located on the main control board. If found open while testing for no circulation and drain pump operation, the fuse and bad pump motor must be replaced. If 120 VAC is not present at J703-3 to J703-4 for the circulation pump or J703-1 to J703-2 for the drain pump, remove and check the fuse at the points shown in the below illustration. If an open fuse is found, replace the fuse and bad pump. The drain pump can be diagnosed by removing connector J703 from the control and check the **blue** to **yellow** wires using a multimeter on the highest resistance setting. If the reading is between 0.3 to 5.0 mega-ohm, then the drain pump is good. If it measures OL (overload or open), it indicates a bad drain pump. If the drain motor checks OK, replace the circulation pump motor. The circulation pump is a DC motor and cannot be checked for a resistance reading, it contains internal diodes and rectifiers.



Pump Motors Fuse
Test Points

Filtration

Good filtration is key to good wash performance.

The ultra-fine filter is consumer removable with a twist lock design. The Owner's Manual advises the consumer to remove and clean every 60 days or more frequently depending on use.

NOTE: Using brushes or scouring pads will damage the filter. To remove, turn the filter counter-clockwise (CCW) and lift from the sump.

Ultra-Fine Filter

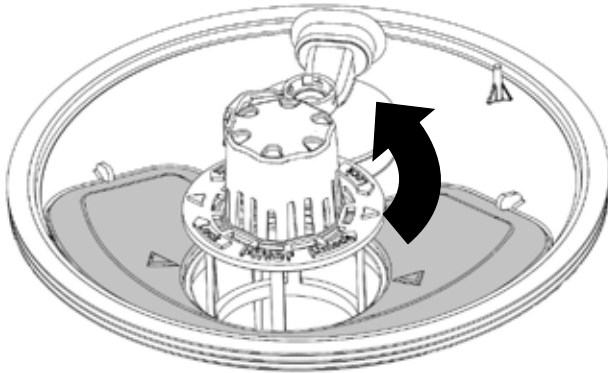

The fine filter is located on the sump assembly and should be cleaned each year or as needed for optimum performance. To remove the fine filter, remove the ultra-fine filter and lift the front of the fine filter to release it from the rear tabs on the sump.

Fine Filter

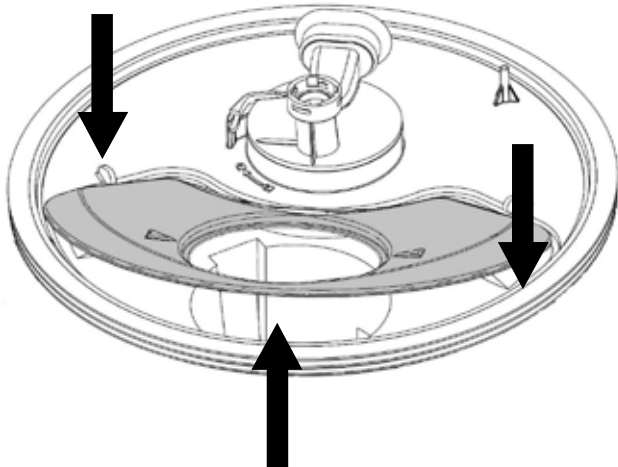

Water is filtered as water flows through both fine and ultra-fine filters. Clean filtered water provides for improved washability.

The fine filter water path is shown below. Water passes through the fine filter and flows on the outside of the ultra-fine filter; passes through the turbidity sensor and into the circulation pump.

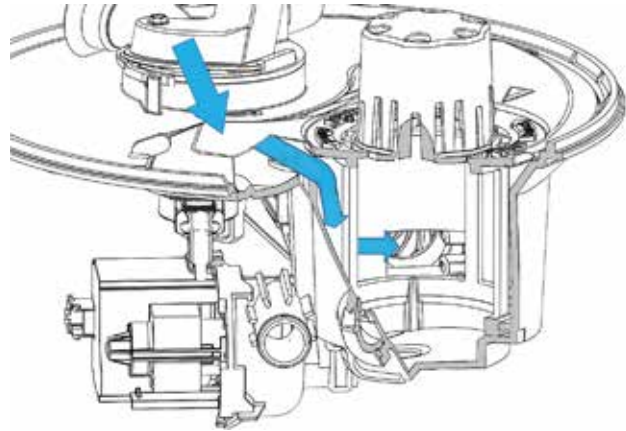

The ultra-fine filter water path is shown below. Water enters the top of the filter, into the sump and through the ultra-fine filter mesh screen. The water mixes with the water that has passed through the fine filter, passes the turbidity sensor and into the circulation pump.

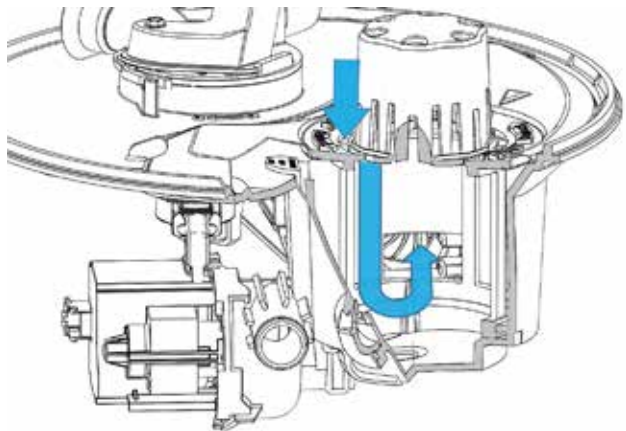

When the dishwasher drains, water is pulled through the ultra-fine filter to help clean it and out the drain port.

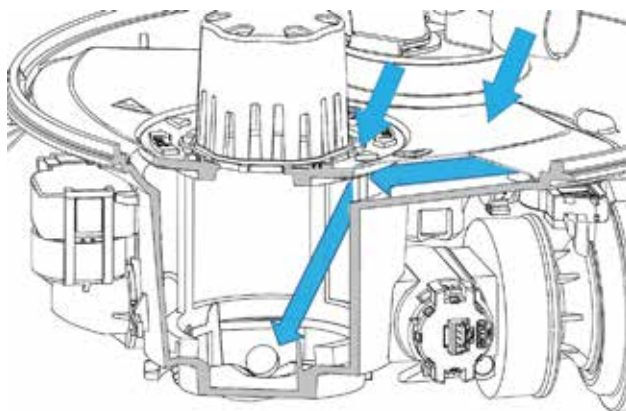

Circulation Motor and Pump Assembly

The circulation motor is a DC brushed motor; it has onboard AC to DC rectification. Resistance cannot be properly checked on this motor because of the rectifier and diodes inside the motor shield.

Circulation Pump Motor Assembly Removal

1. Disconnect power to the dishwasher. Remove the toe kick panel, door, and sump (see **Door Removal** under **Door**, and **Sump Module Removal** under **Sump Module**, in the **Tube and Structure** section of this guide).
2. Loosen the outlet wash motor (diverter) clamp.

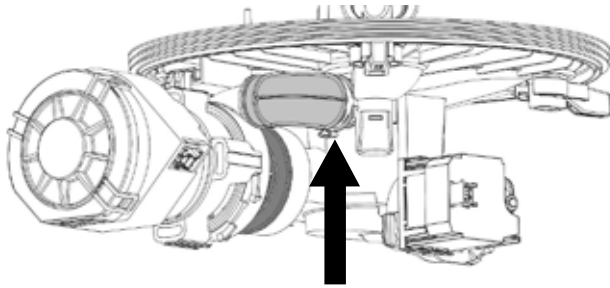

3. Use a large flat-blade screw-driver to slide the circulation motor out of the floating seal. As the pump assembly is removed from the seal, slide the wash motor off of the hanger (use care to not lose the hanger grommet), and remove and discard the one time use clamp.

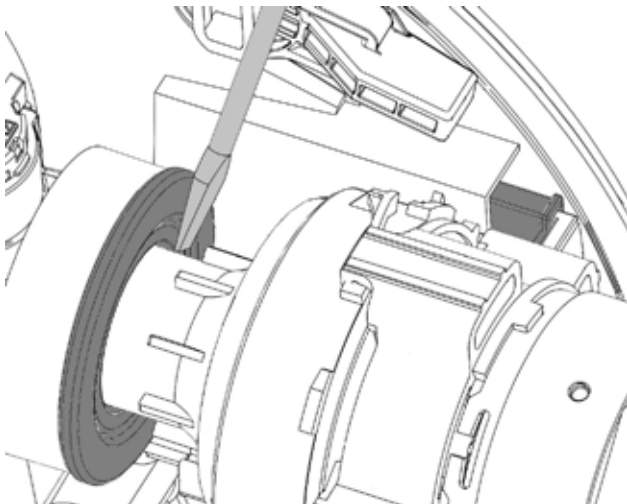

WARNING: GEA Factory Service Technicians are REQUIRED to follow Lockout / Tagout (LOTO) 6 Step Process prior to beginning repair.

Use the flat-blade screw-driver to remove the floating seal from the sump, using care not to damage the inside sealing surface.

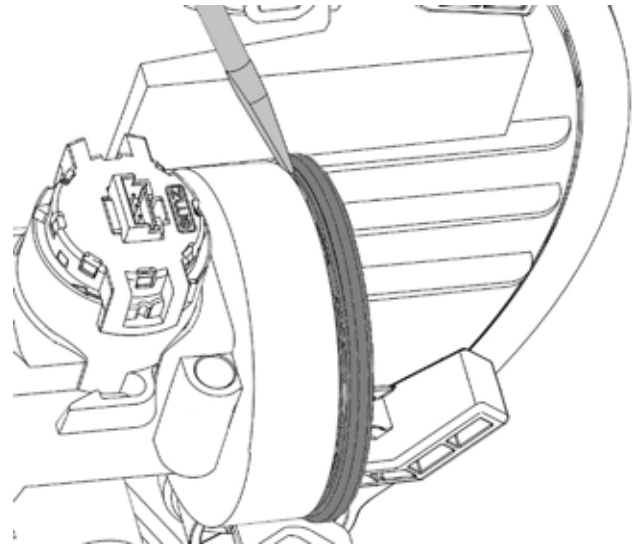

Floating Seal Sealing Surface

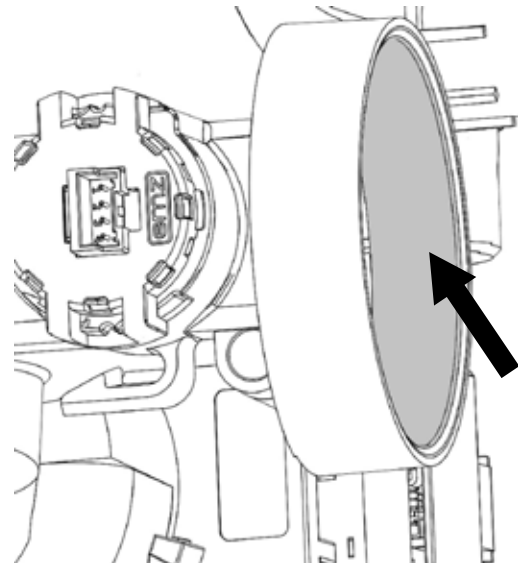

Pump Assembly Grommet

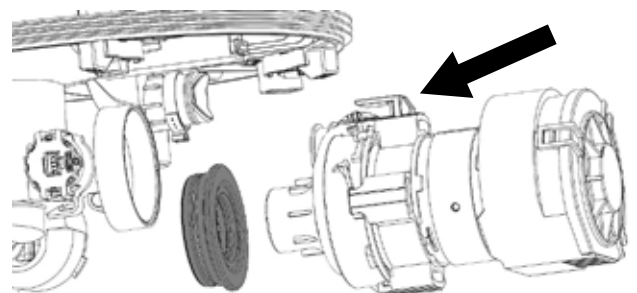

For diagnostic information, please see **Motors Fuse**, located under **No Circulation and Drain** in this section of this guide.

Clamp Removal Tip: Use a small screw-driver inserted into the ear of the clamp and move the handle back and forth to loosen the clamp. The clamp can be removed and discarded when the component is removed. The clamp kit (**Part #:** WD02X25470) contains a single clamp for the diverter connection.

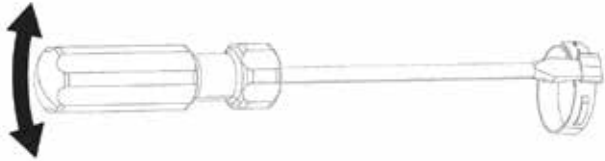

Two-Port Diverter

The two-port diverter is the key component which allows low water use, by alternating water to the lower spray arm or mid spray arm, bottle wash (some models) and upper spray system.

Main Conduit Port (upper spray system)

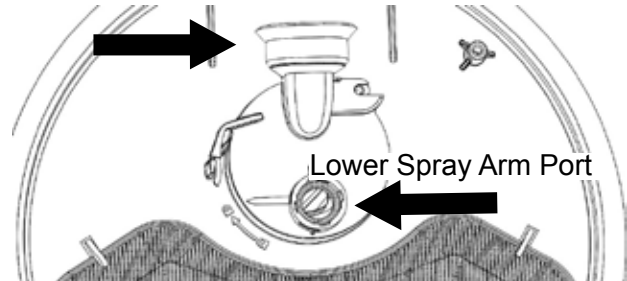

The lower portion of the diverter is molded into the sump. Shown below is the bottom side of the diverter top. Notice the bypass notch in the upper spray system port.

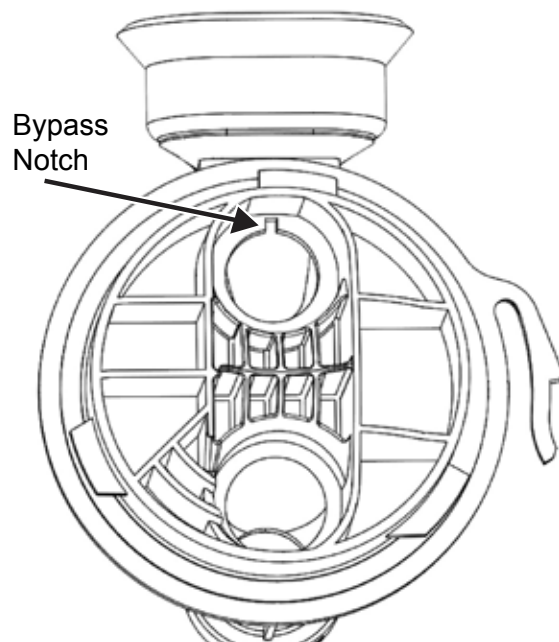

Operation

- The “bypass” allows water to bypass the check ball in the diverter as described in the next step. The dishwasher is in off or standby mode, no pump operation. The check ball is at the bottom of the diverter.

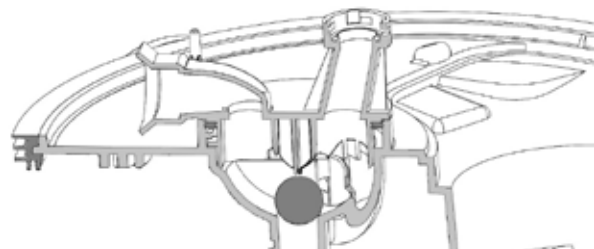

- The wash pump turns on, water flows to the lower spray arm, and the check ball blocks the rear port or upper spray conduit. The bypass allows low pressure and low volume water to enter the main conduit, filling the conduit with no actual spray from the mid and upper wash components.

Lower Spray Arm

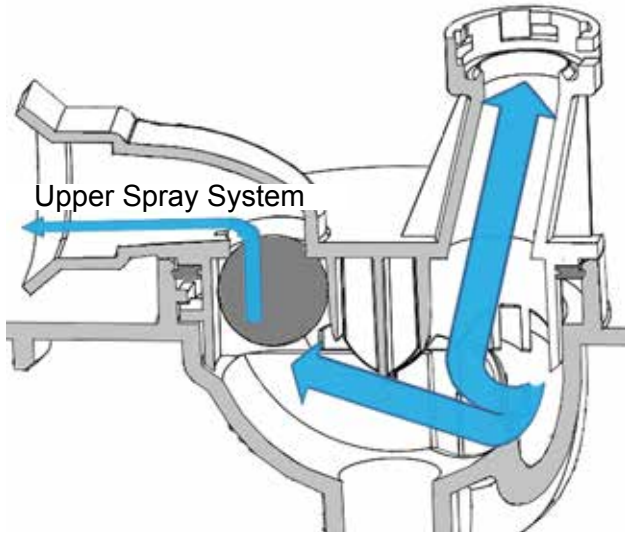

- The wash pump cycles off for one second. Water that is in the rear conduit forces the check ball to the lower spray port.

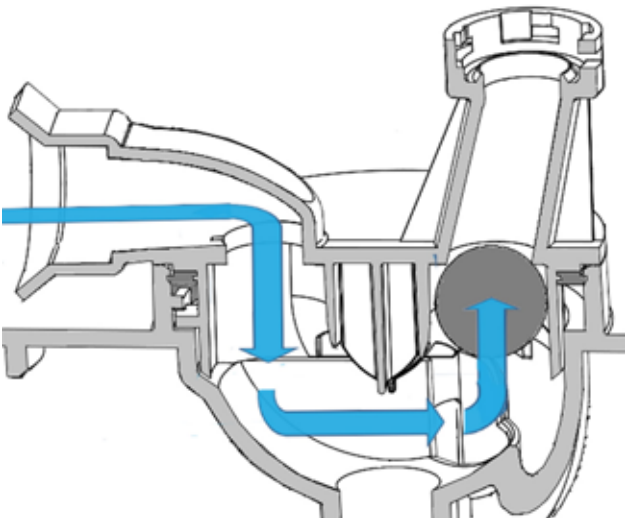

- The wash pump cycles on, and water pressure keeps the check ball positioned to block water entering the lower spray arm. Water flows to the mid spray arm and upper sprayer.

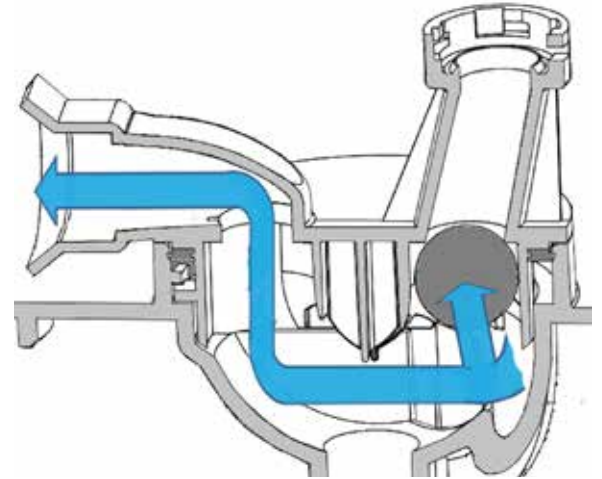

- The wash pump cycles off for eight seconds. The water pressure in the spray arms equalizes, and the check ball is in the bottom or home position.

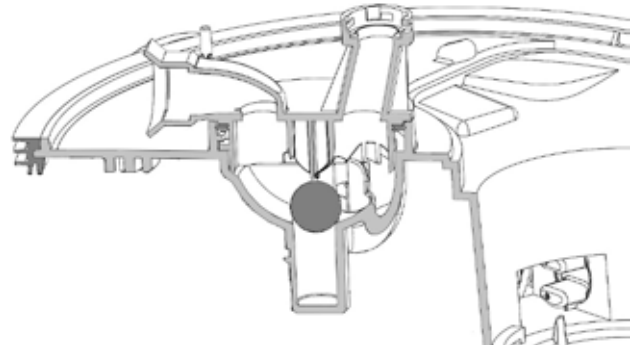

- When the wash pump starts, the check ball again seals the rear port or upper spray arms. The cycle repeats.

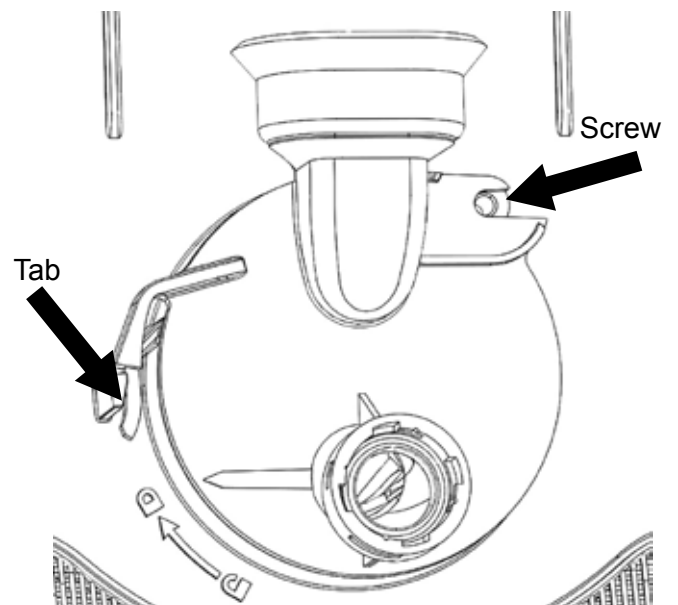

Turbidity Sensor and Thermistor

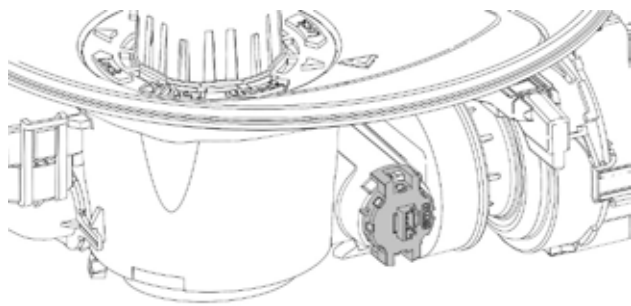

Operation

The turbidity sensor measures the amount of suspended particles in the filtered wash water. The thermistor is also located within the turbidity sensor. The sensor assembly contains a LED transmitter which emits light and a receptor (similar to a photo-cell) which receives light. The wash water passes between the transmitter and receptor, the control interprets these readings to determine the soil level and if any prewash or rinse cycles may be skipped. The cycle design sets parameters to a maximum cycle length; and the turbidity response will shorten the overall cycle length if the soil level is below the cycle preset specifications. By measuring several times during a cycle to monitor soil levels, energy can be saved by removing unneeded rinses, thus shortening the overall cycle time.

If the turbidity sensor fails open or shorted, the control will default to the maximum fills and circulation time that the control is programmed for.

Turbidity Sensor Calibration

Calibration occurs every 100 cycles. After the final rinse but before dry, the control will add three extra rinse cycles. The first cycle will fill, circulate 2-minutes, and drain. The second cycle will be a fill and drain. The third cycle will be a fill, circulate, calibrate, and drain. The cycle will now advance to dry and complete.

Replacement controls will enter a calibration at the end of the first cycle that the control completes, as mentioned above. If the first cycle is interrupted and calibration does not occur, calibration will retry on the next cycle, until it is completed. Calibration will not occur on demand.

Turbidity Sensor Diagnostics

If the turbidity sensor fails open or shorted, the control will default to the maximum fills and circulation time that the control is programmed for. Use **Error Mode** to look for turbidity sensor faults.

Turbidity Sensor Removal

1. Turn the sensor counter-clockwise (CCW).

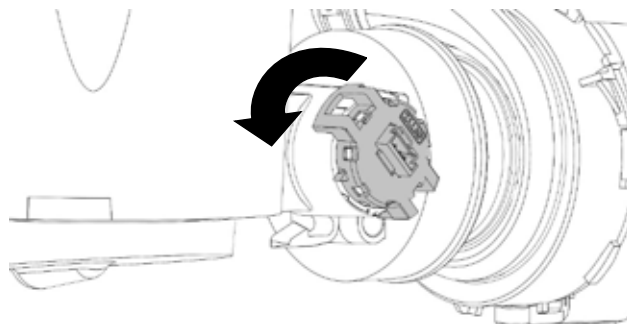

2. Pull the sensor out of the sump.

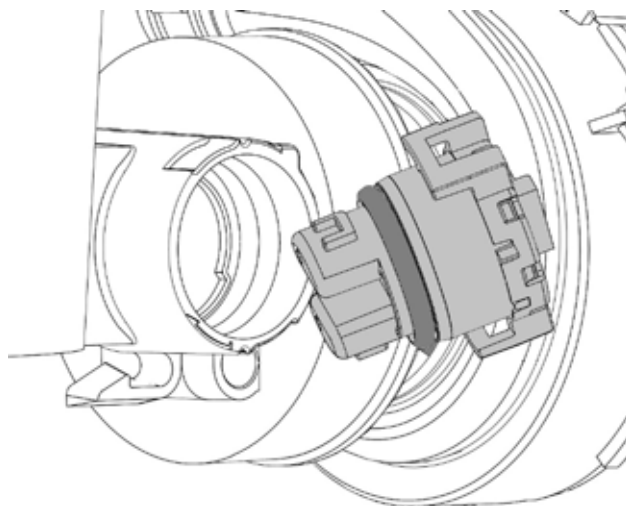

Thermistor

The thermistor is located inside the turbidity sensor. The thermistor monitors water temperature in the tub. If the thermistor opens or shorts it will cause an error (see **Error Mode** in the **Electronic Controls** section of this service guide). If it fails in open or shorted, the control will default to the longest time algorithm.

Thermistor Specifications

VOLTAGE	RESISTANCE	TEMPERATURE
.95	20066	50°F
1.56	10450	75°F
2.25	5824	100°F
2.91	3411	125°F
3.48	2081	150°F
3.91	1330	175°F

To check the thermistor, access the Main Control (see the **Electronic Controls** section of this service guide), check resistance on connector J806, pin 11, CX to pin 8, NX. The sensor may also be removed, and the two outside terminals may be checked. Use the table above to calculate the correct resistance reading.

Main Conduit

The main conduit supplies water to the mid spray arm, bottle wash and the upper spray system.

Main Conduit Removal

1. Remove both lower and upper racks.
2. Remove the lower spray arm.
3. Unclip the top of the conduit from the tub clip at the tub top.

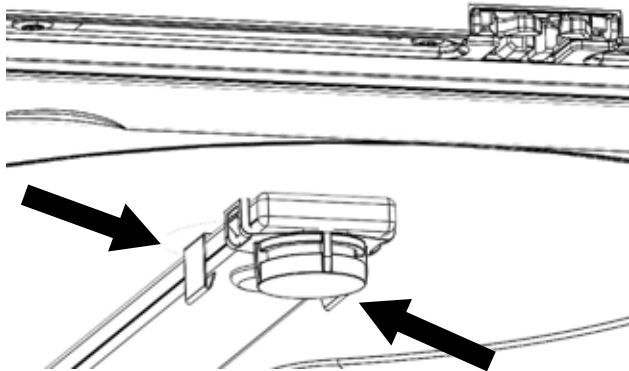

4. Remove the mid spray arm docking port by releasing the tabs on each side of the docking cone. The docking cone will remain attached to the main conduit.

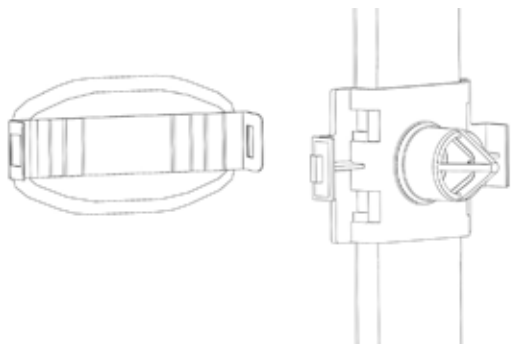

5. Pull the top of the conduit out of the dishwasher to remove the bottom from the diverter top.

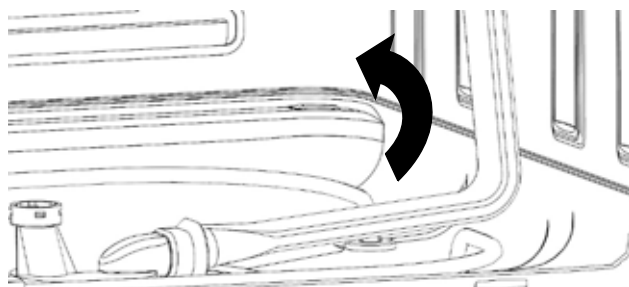

Spray Arms

Lower and mid spray arms are twist lock design and are the similar size and shape. The lower spray arm has heat shields on the bottom and is attached to the diverter. It is possible to reverse the spray arms, which will result in poor washability complaints. Care must be taken to reassemble in the proper position. Some models have an upper spray system which is also twist lock.

Lower Spray Arm

The lower spray arm provides an upward directed water flow, which turns clockwise (CW) when in operation. The arm, bearing, and nut come as a complete assembly and has a twist lock design. To remove, turn the nut counter-clockwise (CCW). Only the lower spray arm has heat shields.



Middle Spray Arm

The mid spray arm provides an upward directed spray pattern to the upper rack. To remove the mid spray arm, turn the nut clockwise (CW), looking down through the upper rack.

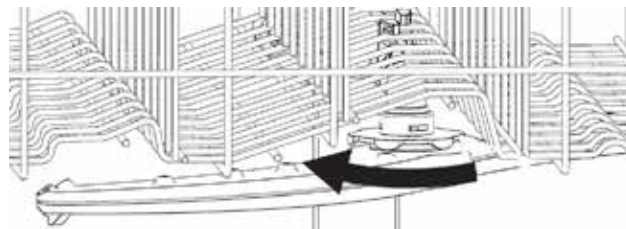

Middle Conduits

The mid-level conduit supplies water from the main conduit to the mid spray arm and bottle wash feature (some models). An adjustable conduit is used to allow proper engagement of the main conduit to the mid conduit in both rack positions.

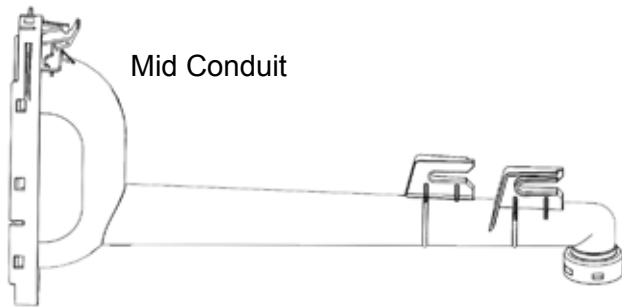

Some models have a port on the right side to allow water flow to the bottle wash feature.

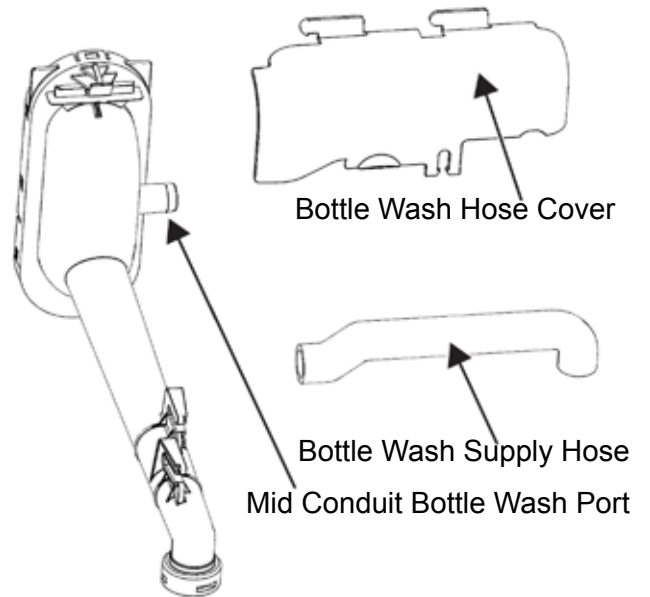

The adjustable conduit has an internal check valve to block wash water from exiting the wash system, keeping water directed into the mid spray arm. The middle conduit is replaced as an assembly, and individual parts for the assembly are not available separately.

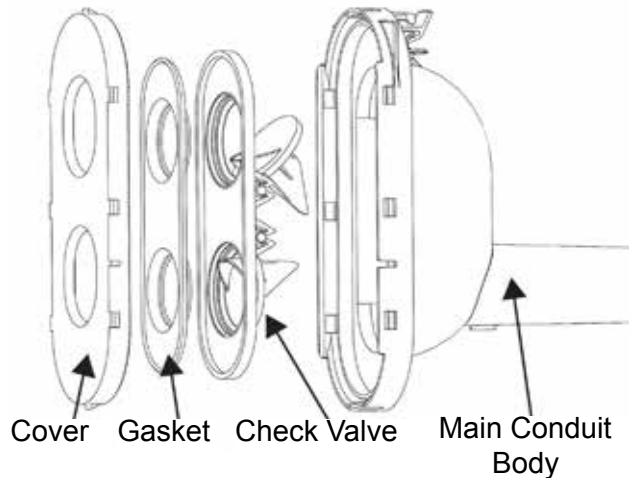

Bottle Wash System (Some Models)

The bottle wash is designed to wash sports bottles, baby bottles, or any dishwasher safe container with a smaller mouth which blocks water from entering the container using normal spray arm jets. This feature insures clean containers. Water is active anytime that the upper spray arm is operational.

Selecting the bottle wash option on the control changes the wash algorithm. The upper spray arm and bottle wash jets are cycled for a longer time, and 23-minutes is added to most cycles when selected. Illustrations for the bottle wash system and removal may be found under **Upper Rack** in the **Racks** section of this service guide.

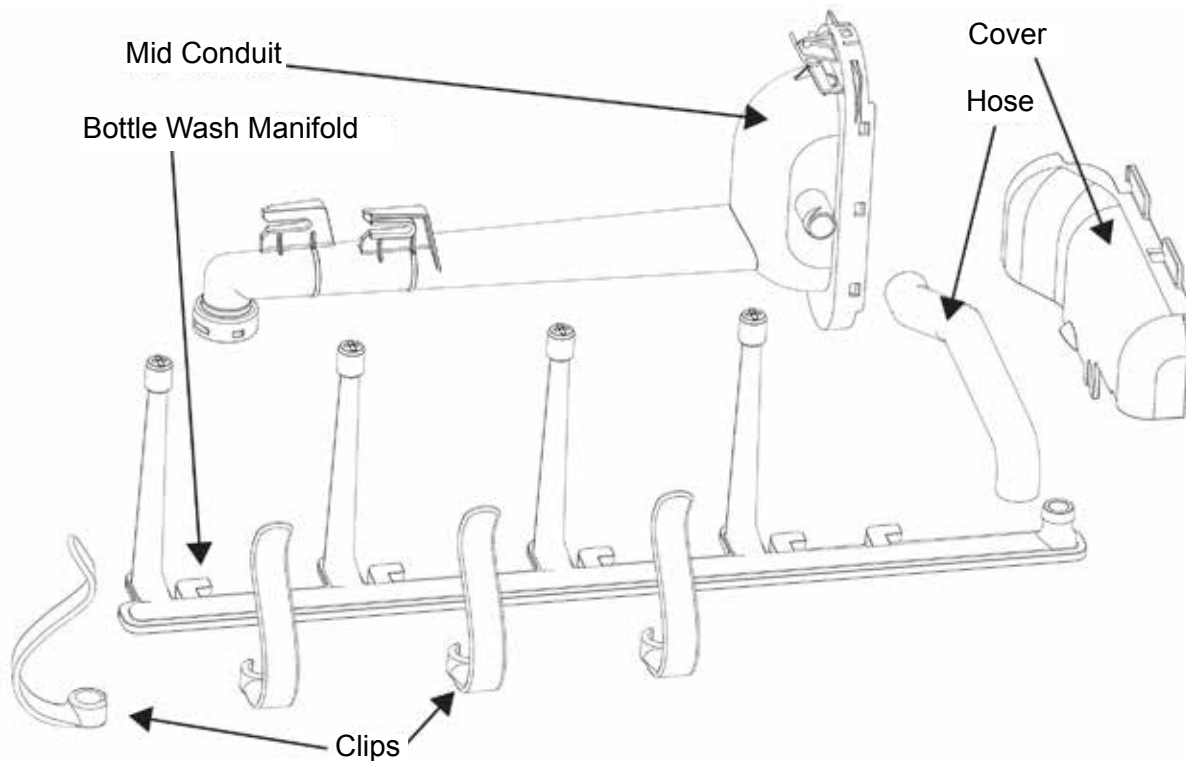

Upper Spray System

The upper sprayer provides a gentle shower down to the top rack.

The spray bracket is attached to the main conduit by means of tabs.

To remove the upper spray system, use a small screw-driver to release the spray system bracket tabs from the main conduit.

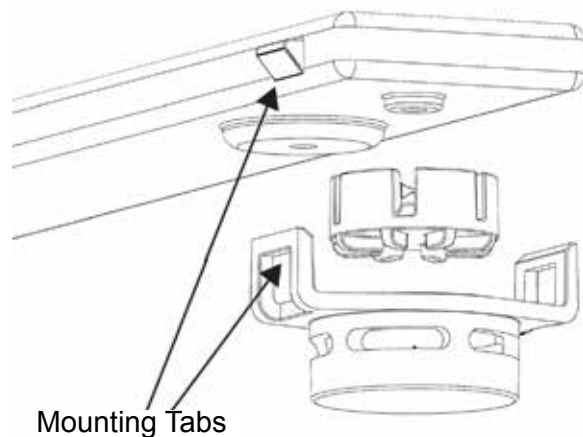

Drain System

Operation

The drain pump operates on 120 VAC. Drain water will back flush the fine filter through the coarse filter, allowing food particles to settle through the floor plate and into the drain pump. It may be normal for the drain pump to start and stop several times during a drain cycle if the pressure sensor does not detect a drain. The drain pump will run with the door open.

Drain Pump Diagnostics

If the fuse for the motors (located on the main control) is found open, remove connector J703 from the control and check the **blue** to **yellow** wires using a multimeter on the highest resistance setting. If the reading is between 0.3 to 5.0 mega-ohms, then that would indicate a good pump. If it measures OL (Open Lead), it indicates an open circuit and that the drain pump is bad. If the drain motor checks OK, replace the circulation pump motor.

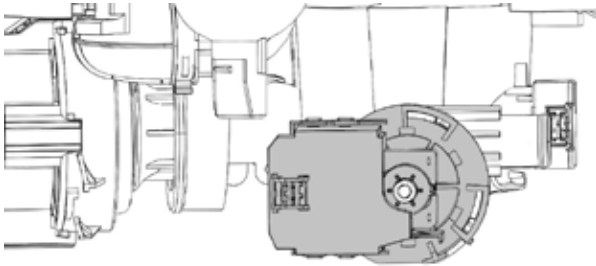

Drain Components

The drain pump is located on the left side of the sump assembly and uses a twist lock connection to the sump. The high drain loop is connected to the drain pump outlet and secured to the side of the tub with molded channels in the tub. The drain hose is connected to the drain loop and to the house drain system. Installation requires the drain hose to provide for a second high drain loop.

- Inside the high drain loop is a check valve preventing drain water from reentering the dishwasher.

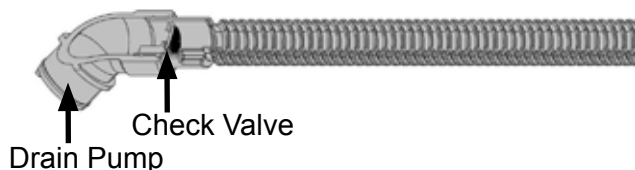

Failure to Drain Symptoms

- F56 fault code
- Water left in tub
- Dishwasher not completing cycle
- Dishwasher will not fill
- Clean indicator LED not coming on
- Detergent cup not opening
- User interface turning off

Failure to Drain Diagnostics

1. Check to see if dishwasher has a failure to drain symptom.
 2. Check air gap and disposer (in the drain pump) for clogging.
 3. Verify the drain pump electrical connection to pump, main board, and inverter board (on some models) are good. Also, verify continuity check on harness.
 4. Verify high drain loop is attached to side of tub.
 5. Validate the home plumbing is not clogged.
 - Time how long it takes the dishwasher to drain while hooked up to the home plumbing. It should take less than 40-seconds. If it takes longer than 40-seconds, unhook the drain hose and drain the dishwasher into a bucket.
1. The drain should take less than 25-seconds to drain into a bucket. If the dishwasher drains properly into a bucket, then the home plumbing likely has a clog and consumer should call a plumbing service.
 2. If the dishwasher takes longer than 25-seconds to drain, verify the drain hose check valve is working properly. If drain hose check valve is good, replace the drain pump and if drain hose check valve is bad/clogged, replace the drain hose.

Failure to Drain Diagnostics

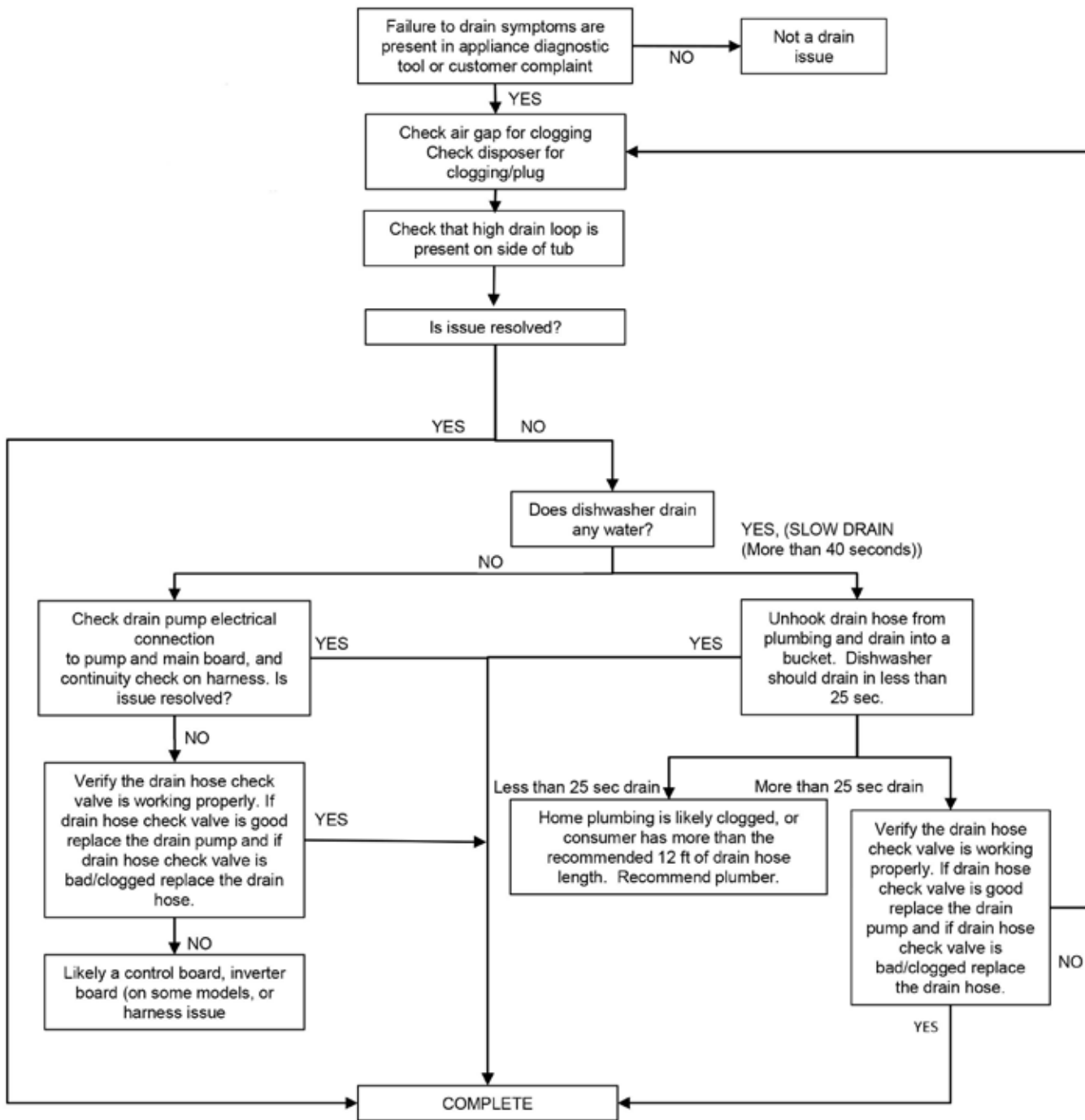

Drain Pump

Drain Pump Removal or Replacement

1. Remove power to the dishwasher.
2. Remove the door (see **Door Removal**, under **Door**, in the **Tub and Structure** section of this service guide).
3. Remove the sump assembly (see **Sump Module Removal**, under **Sump Module** in the **Tub and Structure** section of this service guide).
4. Press in on the locking tab.

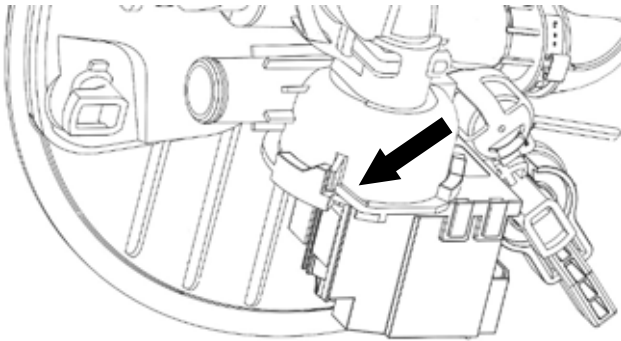

5. Rotate the pump assembly counter-clockwise (CCW) (as viewed from the front of the pump) to remove.

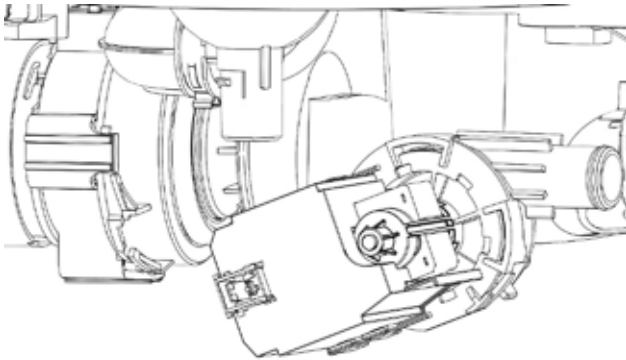

6. Pull out on the pump to finish removal.

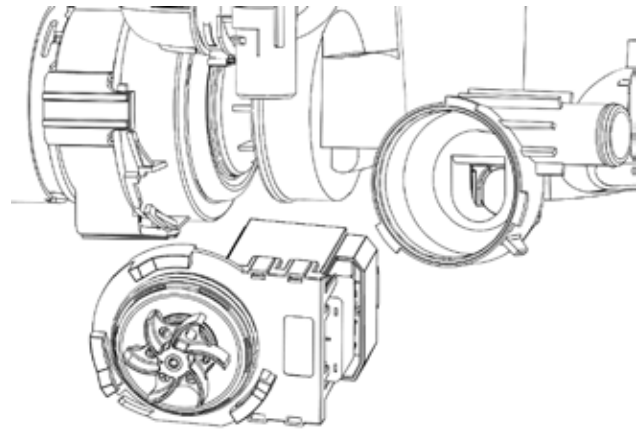

Dry System

Introduction and Operation

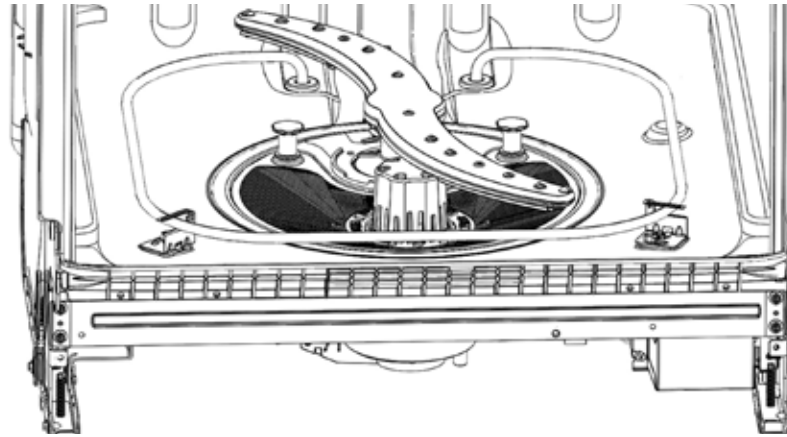

The dual wattage Calrod heater serves both to heat the water during a wash cycle and to heat the air during the dry cycle. Heat and air circulation are required for good dry performance. Air circulation is natural convection with air entering through the fill funnel, then exiting through the vent. Some models have a fan assist dry cycle.

During dry, the heat element cycles after an initial 7-minute on time to 1-minute off, 2-minutes on for 27-minutes and a 14-minute cool down. Boost wash options will change the time needed due to hotter temperatures in rinse for options and cycle selected. The table below represents a normal cycle with heated dry option only selected.

Dual wattage occurs due to the heat level in the element raising the resistance of the internal element. As water quenches the heat on the case, resistance lowers and wattage rises.

The tub thermal cut-off (TCO) has been removed. The machine control board now monitors the heater relay. If the board sees the heater relay closed when it should be open, it will try to open the relay twenty times in 20-seconds. If unsuccessful, the dishwasher will drain and then will terminate the cycle. Resetting the power or entering and exiting Service Mode will reset the fault. The dishwasher can then be started again. The machine control will fault out again after 20-seconds if it still sees the heater relay closed. Replace the machine control board if the fault continues.

Heater Algorithm, Dry Cycle	
Normal with Heated Dry	
Time (minutes)	Calrod Description
7	Calrod on
27	Calrod Pulse - 2 minute on/1 minute off
14	Calrod off - Cool Down
Normal with Temp Boost or Steam/Sani Selected	
7	Calrod on
57	Calrod Pulse - 1 minute on/1 minute off
Boost Dry Option	
7	Calrod on
57	Calrod Pulse - 2 minute on/1 minute off
15	Calrod off - Cool Down

Heater Components

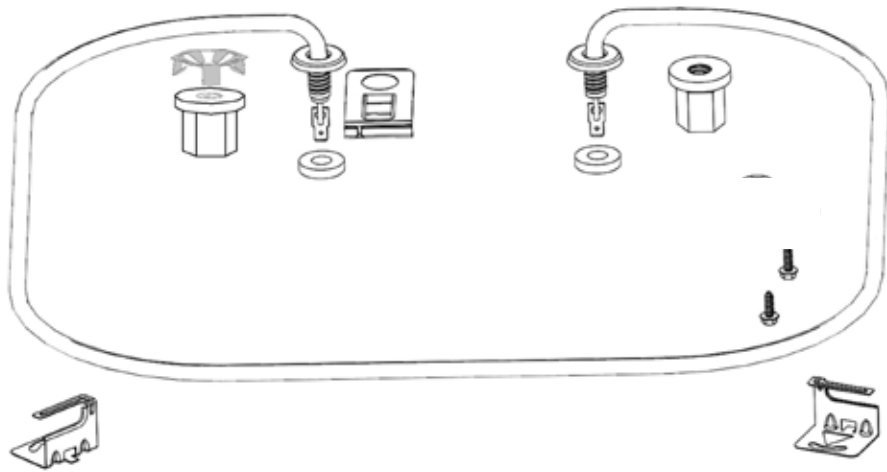

Heater Support Bracket

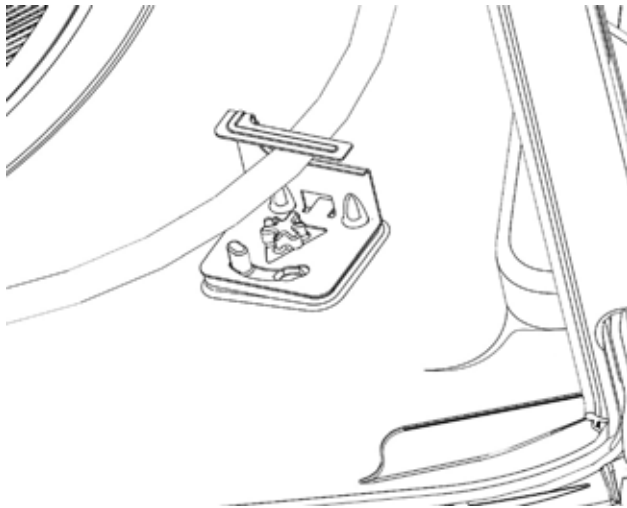

If the feature on the tub will not allow the bracket to lock into place, use screw (Part #: **WD02X10067**) to repair. Place the screw into the boss to lock the bracket in place.

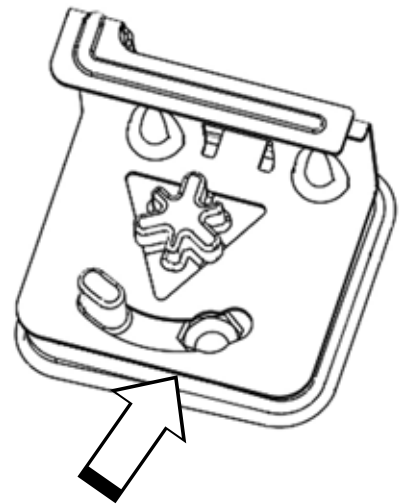

WD02X10067

The heater support bracket has a twist lock design. Turn the bracket clockwise (CW) to release the bracket from the tub mounting feature.

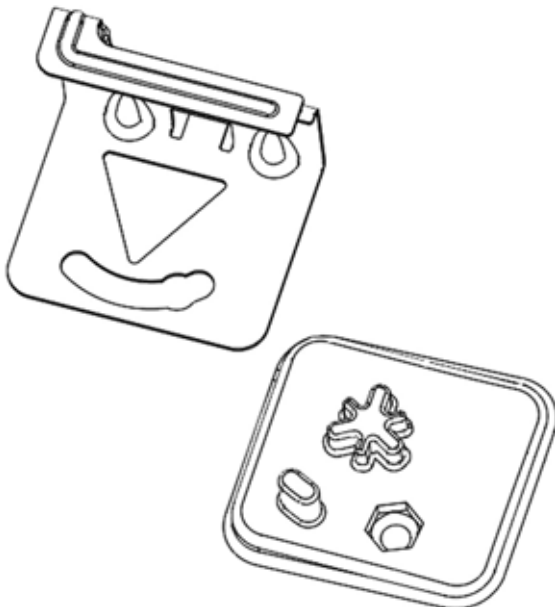

Heater Nut and Ground Clip

Plastic tub dishwashers have a grounding clip on one of the heater nuts. It clips onto the nut as shown below.

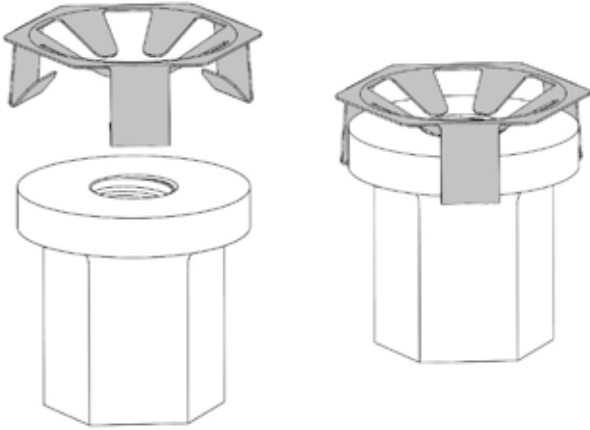

The heater nut with the grounding clip must be used on the left side nut as viewed from the front, right side if viewed from the rear. The grounding nut is critical for proper operation of the CSM.

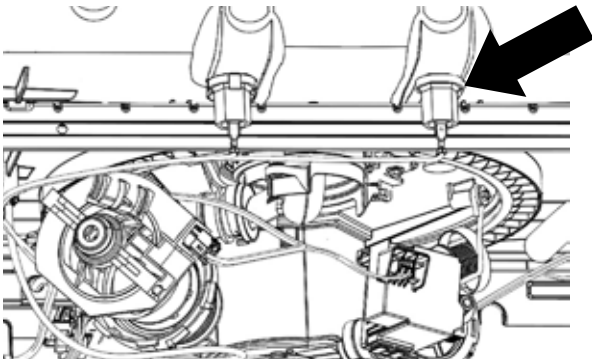

Diagnostics

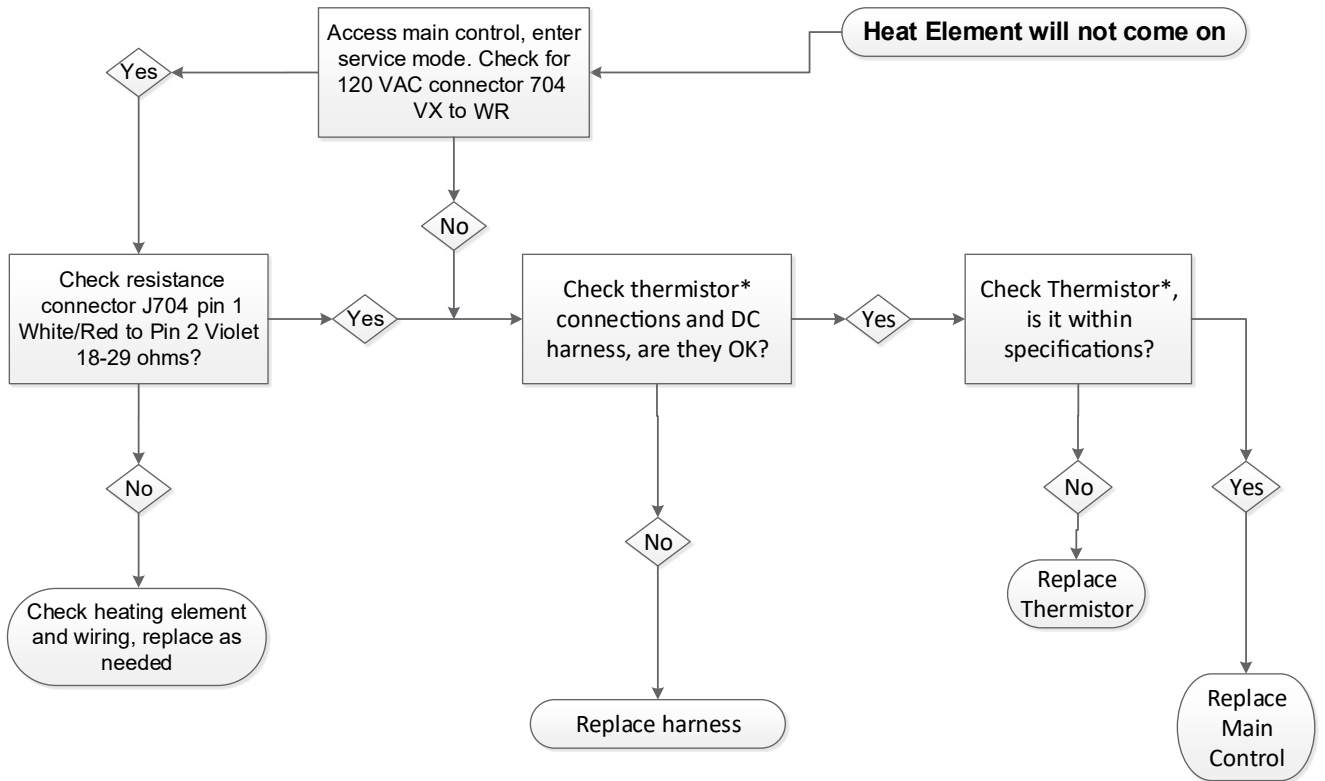

WARNING: GEA Factory Service Technicians are REQUIRED to follow Lockout / Tagout (LOTO) 6 Step Process prior to beginning repair.

Specifications

Heater 120 VAC			
	Wet	Dry	
Watts	800	500	+/- 5%
Ohms	18	28.8	+/- 5%
Amps	6.67	4.17	+/- 5%

Heat Element Removal

The heater may be removed by one of two methods. The first method requires door and sump removal to gain access to the element nuts. The second method requires the dishwasher be removed from its installation.

Element Removal Without Uninstalling the Dishwasher

1. Disconnect power to the dishwasher.
2. Remove the lower rack.
3. Remove the door (see **Door Removal** under **Door** in the **Tub and Structure** section of this service guide).
4. Remove the sump assembly (see **Sump Module Removal**, under **Sump Module** in the **Tub and Structure** section of this service guide).
5. Disconnect the two wire leads to the heater.
6. Remove the two 15/16-inch heater nuts.
7. Remove the heater from inside the dishwasher.

Element Removal by Uninstalling the Dishwasher

1. Disconnect power to the dishwasher.
2. Remove the lower rack.
3. Remove the door (see **Door Removal** under **Door** in the **Tub and Structure** section of this service guide).
4. Remove the dishwasher from its installed position and place on its back.

WARNING: If the door is not removed and the dishwasher is not placed on its back, there is a **TIP RISK**.

5. Disconnect the two wire leads to the heater.
6. Remove the two 15/16-inch heater nuts.

7. Remove the heater from inside the dishwasher.

When reinstalling the element, the ground bracket must be in place and the heater nut with the ground clip must be installed on the left side (as viewed from the front or right side if viewed from the rear).



NOTE: When replacing the heat element, always clean and dry the tub surrounding the ports in tub.



Venting / Airflow

To remove the vent, the door must be removed and separated (see **Door** under the **Tub and Structure** section of this guide).

Fan Assist Venting (on some models)

A fan assembly is located in the door. Components include a 13.5 VDC fan and ducting to the bottom of the door. The power dry system must be removed to access the door control components. Operation, specifications, and diagnostics will be covered in the **Dry System** section of this service guide.

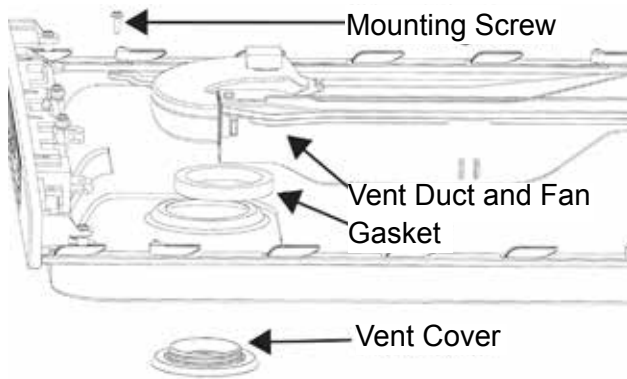

Power Dry System Removal

1. Remove the inner door vent cover.
2. Disconnect the wire harness from the fan to the user interface (UI) control.
3. Remove the 1/4-inch hex-head screw.

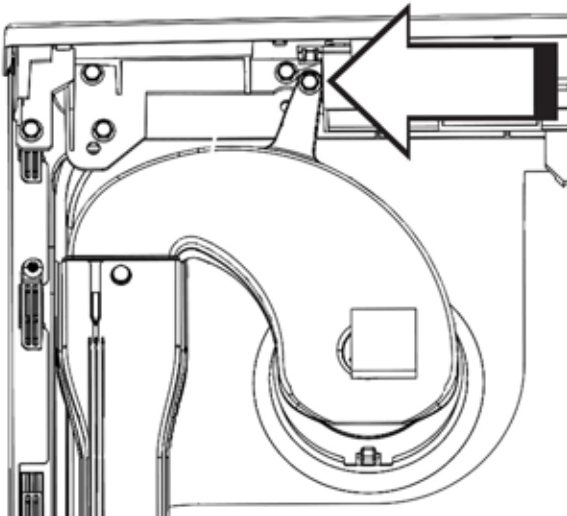

4. The vent conduit, fan and the duct are removed as an assembly.

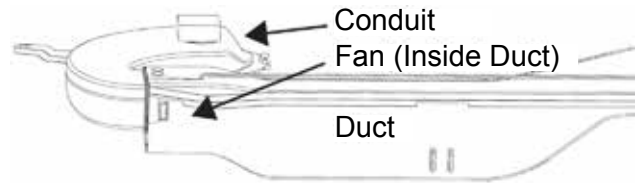

Operation

Heater operation is the same as the passive system. The fan is a brushless motor and operated by 13.5 VDC and runs at 6,000 RPM. There are no consistent resistance readings to make a viable ohm check. A power dry cycle is 50-minutes, then the Clean light comes on. If the consumer does not open the door, the fan will run an extra 90-minutes before shutting off. If the consumer opens the door, the fan will shut off and not restart should the door be closed and latched.

Diagnostics

The door will have to be removed and separated. The door can be plugged back in and put into service mode to make voltage checks. 12 to 14 VDC can be checked at the user interface (UI) board, connector J102 (2-pin connector) from **red** to **black**.

Schematics

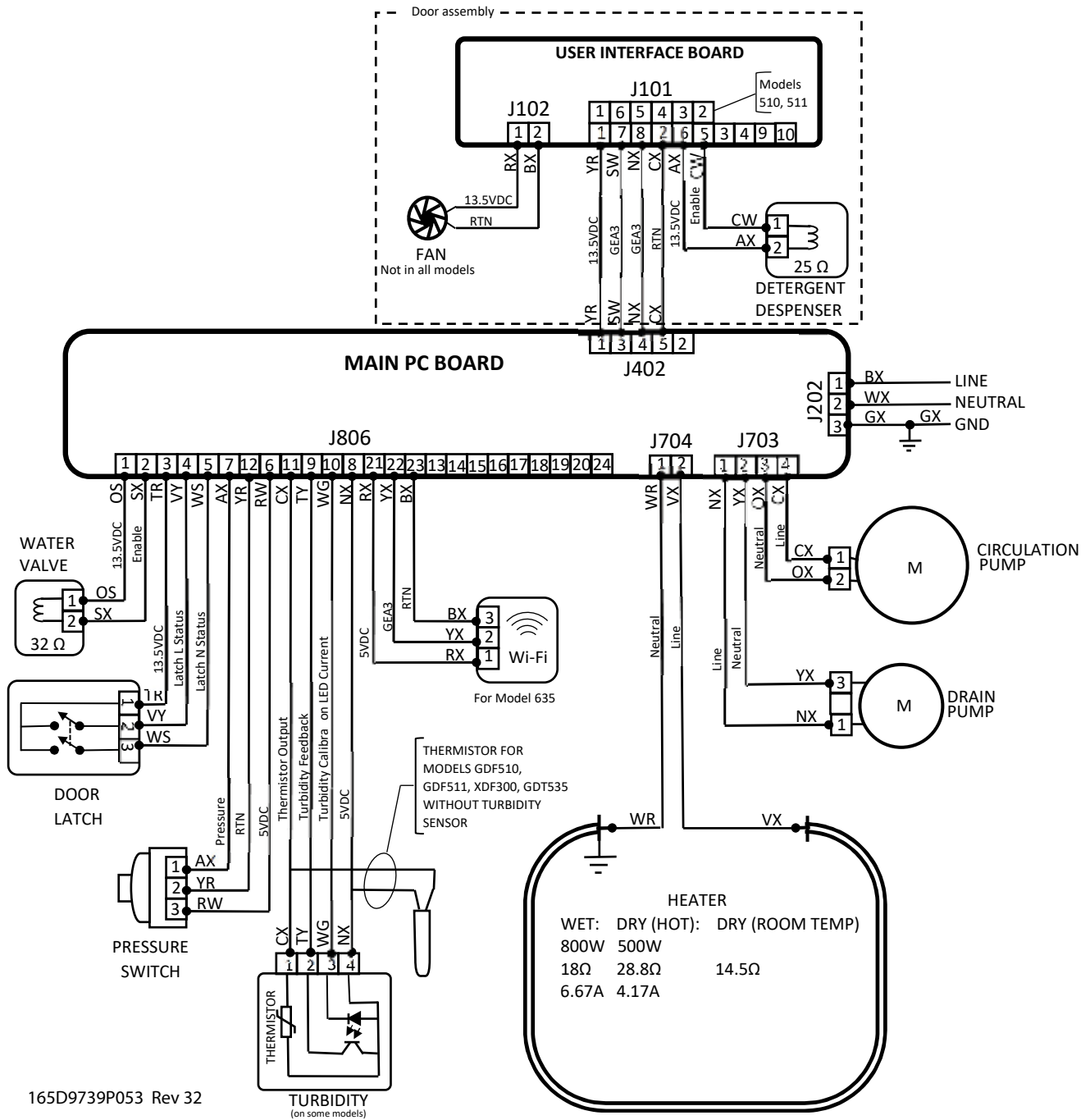

165D9739P053 Rev 32

Solid Colors		Striped Colors	
Color	Designator	Color	Designator
Black	B	Black	B
White	W	Brown	C
Yellow	Y	Green	G
Orange	O	Blue	N
Grey	S	Orange	O
Red	R	Red	R
Dark Blue (Navy)	N	Grey	S
Brown	C	Purple	V
Purple	V	White	W
Green	G	Yellow	Y
Lt Blue (Aqua)	A	None	X
Pink	P		
Tan	T		
Wire color indicated by two-character code. Example: BW is black with white stripe. BX is solid black.			

Index

A

Auto Hot Start 9

B

Buttons 13, 30, 33

C

Circulation Pump 8, 16, 44, 46, 47, 55, 59

Circulation System 19, 55

Clear Door 56

Component Locator Views 13

Critical Faults 4, 46

CSM 12

Current Sense Module 12

Cycle Algorithm Comparisons 9

Cycle Information 9

Cycle Times 9

D

Detergent Dispenser 36

Diverter 5, 9, 16, 39, 44, 55, 60

Door 8, 20, 27, 28, 29, 35, 36, 37, 55, 56, 69, 74, 75

Door Balance System 20

Door Gasket 36

Door Strike 37

Drain Pump 5, 8, 16, 44, 47, 53, 67, 69

Drain System 19, 39, 67

Dry System 9, 27, 70

E

Electronic Controls 12, 43

Error Mode 4, 12, 23, 43, 47, 48, 50, 56, 62, 63, 78

F

Fan 8, 33, 47, 75

Fault Code 43, 44

Fill Funnel 54

Fill System 39, 51

Fill Valve 54

Filtration 55

Flood Switch 8

Front Control Console 30, 32

Front Control UI 30, 31

Fuse 57

G

GDP615H 32

H

Heat Element 74

Hinge 20, 21, 28, 38

Hose 18, 40, 51, 65

I

Inner Door Panel 35

Inner Door Vent Cover 29

J

Junction Box 19

L

Latch Switch Diagnosis 23

Latch System 22

Leveling Legs 20

Light Pipe 31, 33

Lower Rack 18, 25

M

Main Conduit 60, 64, 65

Main Control Board CSM 12, 50

Main Control Diagnostics 12

Middle Spray Arm 64

N

Nomenclature 7

O

Outer Door Panel 35

P

Pocket Handle 30

Power Dry 75

Pressure Sensor 5, 44, 46, 51, 52

Product Specifications 8

S

Schematics 76
Service Mode 36, 47, 48, 51, 56
Silverware Baskets 26
Specifications 8
Spray Arms 64

T

Thermistor 8, 55, 63
Toe Kick 19
Top Control Console Cover 34
Top Control Panel 33
Troubleshooting 12
Tub and Structure 19, 55, 75
Tub Gasket 21, 22
Tub Trim 19
Turbidity Sensor 8, 43, 55, 62
Two-Port Diverter 5, 39, 60

U

UI Diagnostics 50

V

Vent Parts 36

W

Warranty 2
Water Level 51