

## ⚠ WARNING

**Electrical Shock Hazard**

**Disconnect power before servicing.**

**Replace all parts and panels before operating.**

**Failure to do so can result in death or electrical shock.**

## DIAGNOSTIC GUIDE

Before servicing, check the following:

- Make sure there is power at the wall outlet.
- Has a household fuse blown or circuit breaker tripped? Time delay fuse?
- Is dryer vent properly installed and clear of lint or obstructions?
- All tests/checks should be made with a VOM (volt-ohm-milliammeter) or DVM (digital-voltmeter) having a sensitivity of 20,000 ohms per volt DC or greater.
- Check all connections before replacing components. Look for broken or loose wires, failed terminals, or wires not pressed into connectors far enough.
- A potential cause of a control not functioning is corrosion on connections. Observe connections and check for continuity with an ohmmeter.
- Connectors: Look at top of connector. Check for broken or loose wires. Check for wires not pressed into connector far enough to engage metal barbs.
- Resistance checks must be made with dryer unplugged or power disconnected.

## DIAGNOSTIC TESTS

These tests allow factory or service personnel to test and verify all inputs to the machine control electronics. You may want to do a quick and overall checkup of the dryer with these tests before going to specific troubleshooting tests.

### ACTIVATING THE DIAGNOSTIC TEST MODE

1. Be sure the dryer is in standby mode (plugged in and all indicators off).
2. Press the following button sequence:  
+ (more time), – (less time), + (more time), – (less time), all within 5 seconds.
3. All indicators on the console are illuminated with **88** showing in the Estimated Time Remaining (two-digit) display, if this test mode has been entered successfully.

## IMPORTANT

### Electrostatic Discharge (ESD) Sensitive Electronics

ESD problems are present everywhere. ESD may damage or weaken the electronic control assembly. The new control assembly may appear to work well after repair is finished, but failure may occur at a later date due to ESD stress.

- Use an anti-static wrist strap. Connect wrist strap to green ground connection point or unpainted metal in the appliance  
-OR-  
Touch your finger repeatedly to a green ground connection point or unpainted metal in the appliance.
- Before removing the part from its package, touch the anti-static bag to a green ground connection point or unpainted metal in the appliance.
- Avoid touching electronic parts or terminal contacts; handle electronic control assembly by edges only.
- When repackaging failed electronic control assembly in anti-static bag, observe above instructions.

### If unsuccessful entry into diagnostic mode, actions can be taken for specific indications:

**Indication 1:** None of the indicators or display turns on.

**Action:** Select any manual cycle.

- If indicators come on, then try to change the dryer time by pressing the + and – buttons. If either button fails to change the time, something is faulty with one of those buttons, and it is not possible to enter the diagnostic mode. Remove the console electronics and housing. See Accessing & Removing the Electronic Assemblies, page 7.

- If no indicators come on after pressing the Manual cycle buttons, go to TEST #1, page 3.

**Indication 2:** E1 or E2 flashes from the display.

**Action:** Proceed to TEST #3a, page 4.

**Indication 3:** E3 flashes from the display.

**Action:** Check that the correct machine control electronics and console electronics and housing are installed. Do so by removing these components to view the part numbers and compare them to the part numbers in the Service Parts List

for this unit. See Accessing & Removing the Electronic Assemblies, page 7. Replace components if necessary.

### Diagnostic: Console switches and indicators

Pressing each button or turning the cycle selector to each cycle should cause a beep tone and control one or more LEDs as shown in figure 1, page 3. Pressing the Hold To Start button will also control the motor and heater, while the two-digit display will indicate a software project i.d. number.

### Diagnostic: Moisture Sensor

Locate two metal strips on the face of the lint screen housing. Bridge these strips with a wet cloth or a finger.

- If a beep is heard and a software revision number is displayed on the console, the sensor is OK.
- If not, or if a beep tone is heard before bridging the moisture strips, go to TEST #4, step 2, page 5.

### Diagnostic: Door Switch

Opening the door should cause a beep tone and a number and letter to be indicated in the two-digit display. Closing the door firmly should cause a beep tone and the display to go blank or indicate **88**.

## DISPLAY FAULT/ERROR CODES

The error codes below would be indicated when attempting to start a drying cycle, or after activating the diagnostic test mode.

DISPLAY	DESCRIPTION	EXPLANATION AND RECOMMENDED PROCEDURE
<i>PF</i>	<b>POWER FAILURE</b>	<b>PF</b> flashes to indicate that a power failure occurred while the dryer was running. Press <b>HOLD TO START</b> to continue the cycle, or press <b>OFF/Pause</b> to clear the display.
<i>E1</i>	<b>THERMISTOR OPEN</b>	<b>E1</b> flashes if the thermistor is open. See TEST #3a, page 4.
<i>E2</i>	<b>THERMISTOR SHORTED</b>	<b>E2</b> flashes if the thermistor has shorted. See TEST #3a, page 4.
<i>E3</i>	<b>USER INTERFACE OR SOFTWARE MISMATCH</b>	<b>E3</b> flashes when there is a keyswitch or software mismatch. This error code will <b>ONLY</b> appear when in the diagnostic test mode. See TEST #5, page 6.

**ELECTRIC DRYER WIRING DIAGRAM**

**IMPORTANT:** Electrostatic (static electricity) discharge may cause damage to electronic control assemblies. See page 1 for details.

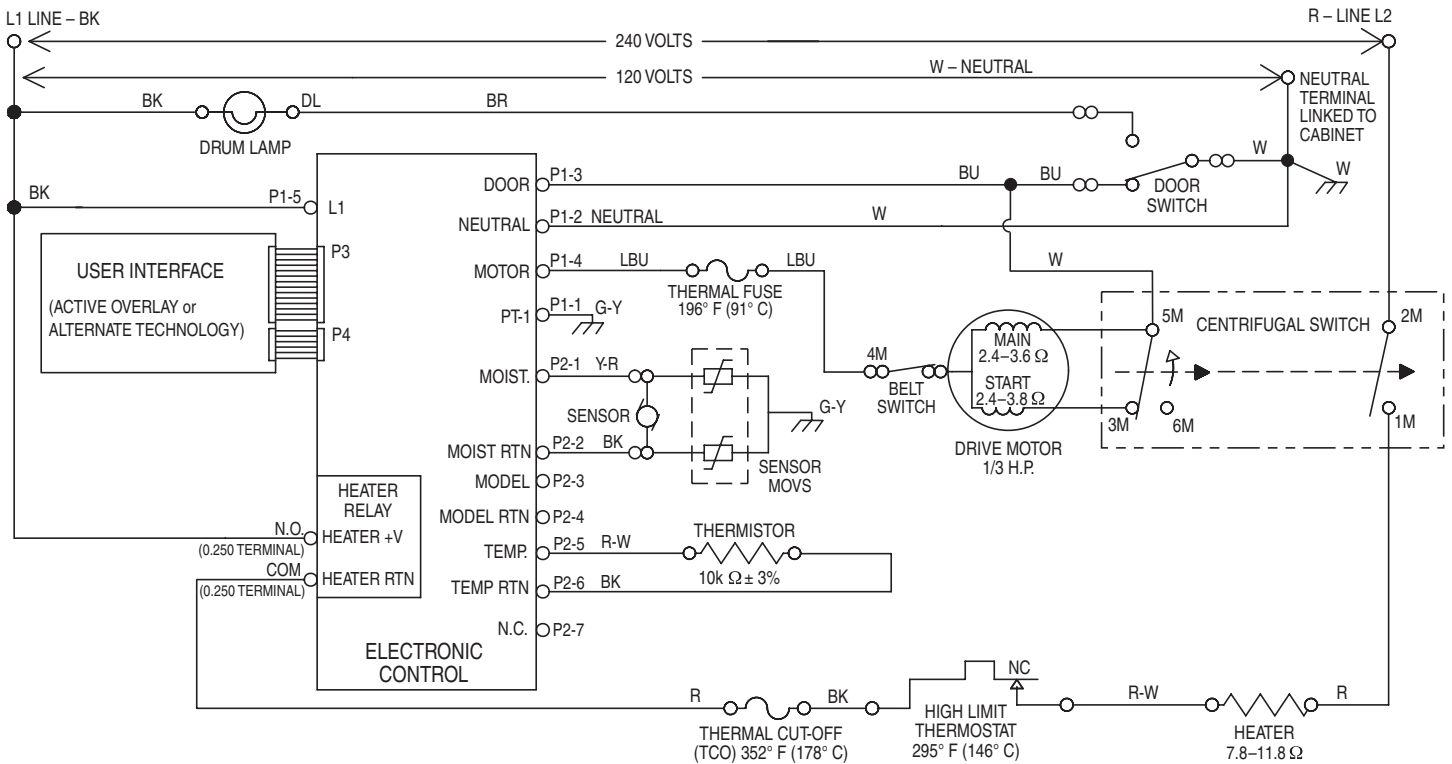

**TROUBLESHOOTING GUIDE**

Some tests will require accessing components. See figure 13, page 7 for component locations.

<b>Drum Size:</b>	<b>Drum Speed:</b>
7.0 cubic feet	51.5 ± 3 RPM CW

PROBLEM	POSSIBLE CAUSE / TEST
<b>NOTE:</b> Possible Cause/Tests MUST be performed in the sequence shown for each problem.	
<b>WON'T POWER UP.</b> (No response when Control On button is pressed.)	<ol style="list-style-type: none"> <li>1. Supply Connections. See TEST #1, page 3.</li> <li>2. Check harness connections.</li> <li>3. Console electronics and housing. See TEST #5, page 6.</li> </ol>
<b>WON'T START CYCLE WHEN HOLD TO START BUTTON IS PRESSED.</b>	<ol style="list-style-type: none"> <li>1. If number display flashes, check to be sure the door is completely shut, and press and hold down HOLD TO START for about 1 second.</li> <li>2. See TEST #2, page 3.</li> <li>3. See TEST #6, page 6.</li> </ol>
<b>WON'T SHUT OFF WHEN EXPECTED.</b>	<ol style="list-style-type: none"> <li>1. Check OFF/Pause button. See TEST #5, page 6.</li> <li>2. Console electronics and housing. See TEST #5, page 6.</li> <li>3. Moisture Sensor. See TEST #4, page 5.</li> </ol>
<b>CONTROL WON'T ACCEPT SELECTIONS.</b>	Console electronics and housing. See TEST #5, page 6.
<b>WON'T HEAT.</b>	<ol style="list-style-type: none"> <li>1. Heater. See TEST #3, page 4.</li> <li>2. Check harness connections.</li> <li>3. Check installation.</li> </ol>
<b>HEATS IN AIR CYCLE.</b>	Thermistor. See TEST #3a, page 4.
<b>SHUTS OFF BEFORE CLOTHES ARE DRY.</b>	Moisture Sensor. See TEST #4, page 5.

Function	Contacts				
	1M	2M	3M	5M	6M
Start			●	●	
Run	●	●		●	●

● = Contacts closed

**Centrifugal Switch (Motor)**

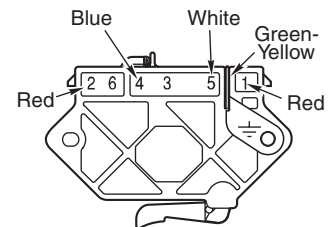

**Pluggable Drive Motor Switch**

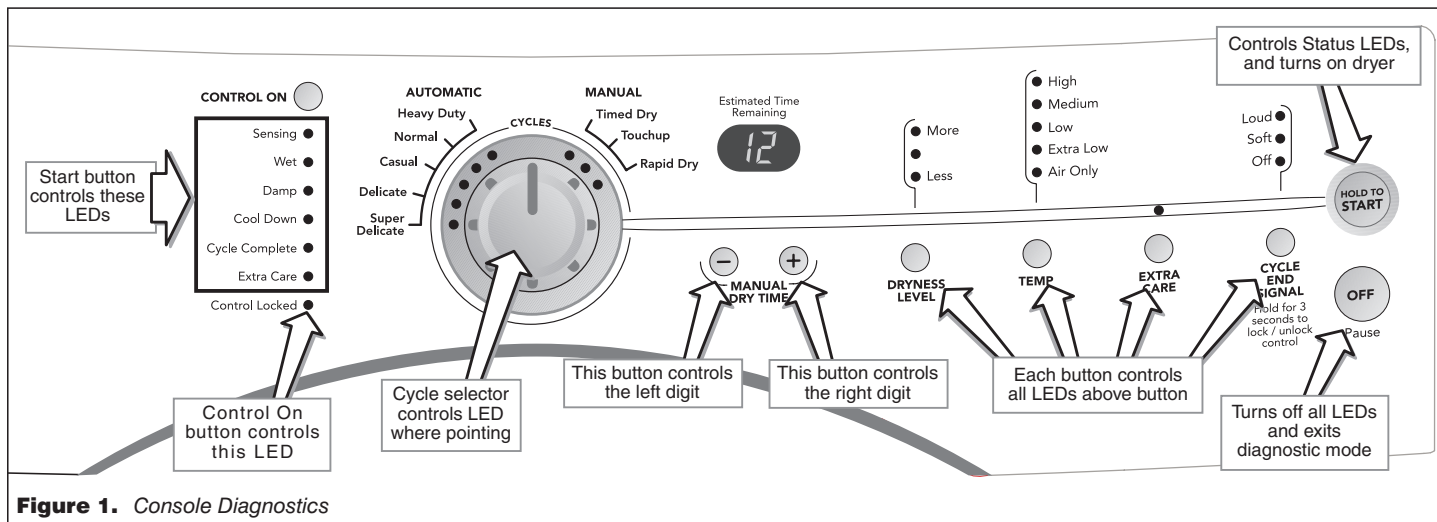

Figure 1. Console Diagnostics

### TROUBLESHOOTING TESTS

**NOTE:** These checks are done with the dryer unplugged or disconnected from power.

#### TEST #1 Supply Connections

This test assumes that proper voltage is present at the outlet, and visual inspection indicates that the power cord is securely fastened to the terminal block.

1. Unplug dryer or disconnect power.
2. Remove the cover plate from the top right corner of the back of the dryer. See figure 2.

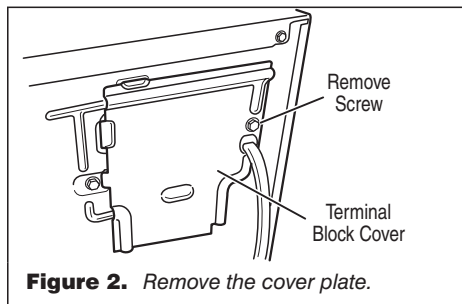

Figure 2. Remove the cover plate.

3. With an ohmmeter, check for continuity between the neutral (N) terminal of the plug and the center contact on the terminal block. See figure 3.

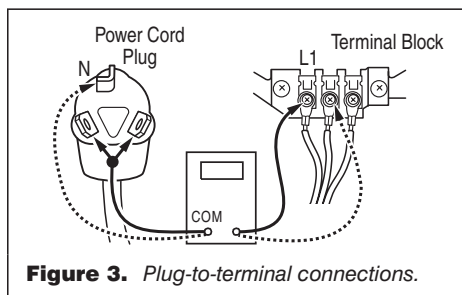

Figure 3. Plug-to-terminal connections.

- If there is no continuity, replace the power cord and test the dryer.
  - If there is continuity, go to step 4.
4. In a similar way, check which terminal of the plug is connected to the left-most contact on the terminal block and make a note of it. This

will be L1 (black wire) in the wiring diagram. See figure 3.

- When this is found, go to step 5.
- If neither of the plug terminals have continuity with the left-most contact of the terminal block, replace the power cord and test the dryer.

5. Access the machine control electronics without disconnecting any wiring to the control board. See Accessing & Removing the Electronic Assemblies, page 7.
6. With an ohmmeter, check for continuity between the L1 terminal of the plug (found in step 4) and P1-5 (black wire) on the machine control board.

- If there is continuity, go to step 7.
- If there is no continuity, check that wires to the terminal block are mechanically secure. If so, replace the main wire harness and test the dryer.

7. Check for continuity between the neutral (N) terminal of the plug and P1-2 (white wire) at the control board.

- If there is continuity, go to step 8.
- If there is no continuity and the mechanical connections of the wire are secure, replace the main wire harness.

8. If the dryer still does not operate, replace the machine control electronics.

#### TEST #2 Motor Circuit

This test will check the wiring to the motor and the motor itself. The following items are part of this system:

- Harness/connection
- Thermal fuse
- Belt/belt switch
- Drive Motor
- Door switch
- Machine control electronics. See ESD information, page 1.

1. Unplug dryer or disconnect power.
2. Access the machine control electronics. See Accessing & Removing the Electronic Assemblies, page 7. Measure the resistance across P1-3 and P1-4.

- If resistance across P1-3 and P1-4 is in the range of 1 to 6 ohms, replace the machine control electronics.

→ Otherwise, go to step 3.

3. Check the wiring and components in the path between these measurement points by referring to the wiring diagram on page 2.
4. Check the thermal fuse. See TEST #3b, page 5.
5. Check the belt switch and drive motor. Access the belt switch and drive motor by removing the back panel. See Removing the Back Panel, page 8. Slowly remove the drum belt from the spring-loaded belt switch pulley, gently letting the belt switch pulley down. See figure 4.

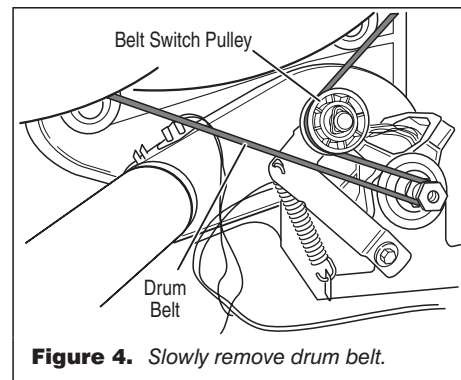

Figure 4. Slowly remove drum belt.

6. Remove the white connector from the drive motor switch. See figure 5.

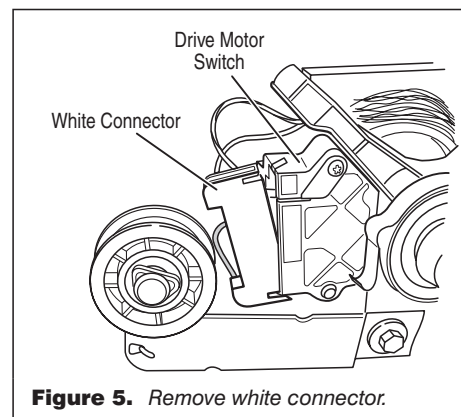
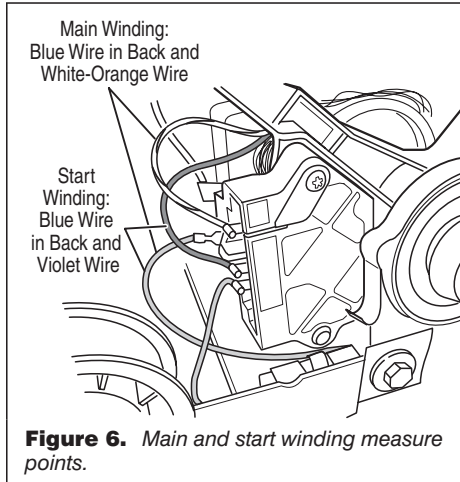

Figure 5. Remove white connector.

7. Using figure 6, check for the resistance values of the motor's Main and Start winding coils as shown below.

**NOTE:** Main and Start winding coils must be checked at the motor.

WINDING	RESISTANCE Ω	CONTACT POINTS OF MEASUREMENT
MAIN	2.4–3.6	Blue wire in back and white-orange wire
START	2.4–3.8	Blue wire in back and violet wire



- If the resistance at the motor is correct, then there is an open circuit between the motor and machine control electronics. Check for failed belt switch (step 8).
- If the Start winding resistance is much greater than 4 ohms, replace the motor.

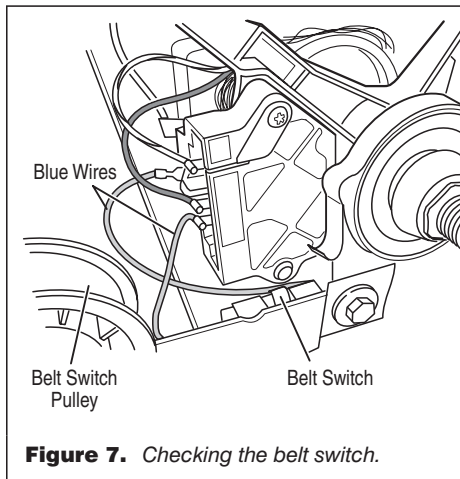

8. Check the belt switch by measuring resistance between the two blue wires, as shown in figure 7, while pushing up the belt switch pulley.

- If the resistance reading goes from infinity to a few ohms as pulley arm closes the switch, belt switch is OK. If not, replace the belt switch.
- If belt switch is OK and there is still an open circuit, check and repair the wiring harness.

9. Door switch problems can be uncovered in the Diagnostic Tests, page 1; however, if this was not done, the following can be done without applying power to the dryer. Connect an ohmmeter across P1-2 (neutral, white wire) and P1-3 (door, blue wire).

- With the door properly closed, the ohmmeter should indicate a closed circuit (0–2 ohms).
- If not, replace the door switch assembly.

**TEST #3 Heater**

This test is performed when either of the following situations occur:

- ✓ Dryer doesn't heat
- ✓ Heat won't shut off

This test checks the components making up the heating circuit. The following items are part of this system:

- Harness/connection
- Heater relay
- Thermal cut-off
- High limit thermostat
- Heat element assembly
- Centrifugal switch
- Thermistor
- Machine control electronics. See ESD information, page 1.
- Console electronics

**Dryer does not heat:**

1. Unplug dryer or disconnect power.
2. Remove the toe panel to access the thermal components. See figure 11, page 7. Locate the components using figure 8.

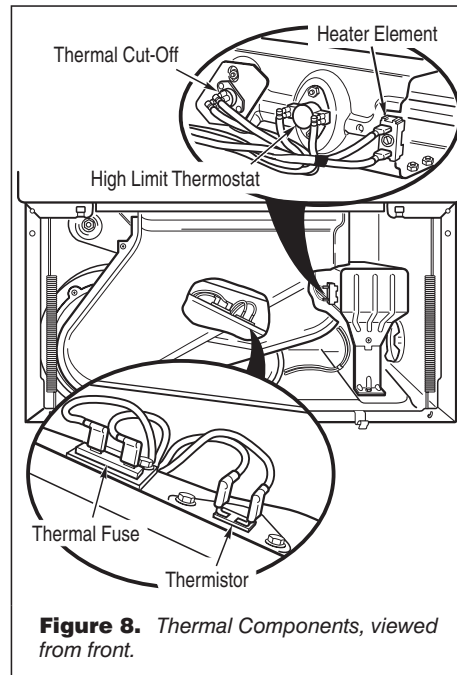

3. Using an ohmmeter and referring to the wiring diagram, measure the resistance from the red wire terminal at the thermal cutoff to the red wire terminal at the heater.

- If the resistance is about 10 ohms, go to step 5.
- If an open circuit is detected, go to step 4.

4. Visually check the wire connections to the thermal cutoff, high limit thermostat, and heater. If connections look good, check for continuity across each of these components. Replace the one that is electrically open.

5. If no open circuit is detected, access the machine control electronics. See Accessing & Removing the Electronic Assemblies, page 7. Remove the P2 connector, then measure the resistance between P2-5 (red-white wire) and P2-6 (black wire) at the connector.
  - If 6–7 k ohms are measured, replace the machine control electronics.
  - If the resistance is less than 1 k ohm, replace the thermistor.

**Heat will not shut off:**

1. Unplug dryer or disconnect power.
2. Access the machine control electronics. See Accessing & Removing the Electronic Assemblies, page 7. Remove the P2 connector, then measure the resistance between P2-5 (red-white wire) and P2-6 (black wire) at the connector.
  - If 6–7 k ohms are measured, replace the machine control electronics.
  - If the resistance is much greater than 7 k ohms, replace the thermistor.

**TEST #3a Thermistor**

The machine control electronics monitors the exhaust temperature using the thermistor, and cycles the heater relay on and off to maintain the desired temperature.

Begin with an empty dryer and a clean lint screen.

1. Plug in dryer or reconnect power.
2. Set the following configuration:
  - Door – must be firmly closed
  - Press CONTROL ON
  - Press CYCLE END SIGNAL (Loud)
  - Press HOLD TO START
3. If after 60 seconds, *E1* or *E2* flashes in the display and the dryer shuts off, the thermistor or wire harness is either shorted or open.
  - Unplug dryer or disconnect power.
  - Check wire connections at the machine control electronics and thermistor. See Accessing & Removing the Electronic Assemblies, page 7; and figure 8 for thermistor location.
  - If wire connections are good, remove the two wires from the thermistor and replace the thermistor.
  - Plug in dryer or reconnect power.
4. If *E1* or *E2* does not flash in the display, the connections to the thermistor are good. Therefore, check the exhaust temperature value at any or all of the temperature levels in question, using the Timed Dry cycle, and the following process:

Hold a glass bulb thermometer capable of reading from 90° to 180°F (32° to 82°C) in the center of the exhaust outlet. The correct exhaust temperatures are as follows:

EXHAUST TEMPERATURES		
TEMP. SETTING	HEAT TURNS OFF* °F (°C)	HEAT TURNS ON °F (°C)
High	155°±10° (68°±6°)	10°–15° (6°–8°) below the heat turn off temperature
Medium	140°±10° (60°±6°)	
Low	125°±10° (52°±6°)	
Extra Low	105°±5° (41°±3°)	

\* The measured overshoot using the glass bulb thermometer in the exhaust outlet can be 30°F (17°C) higher.

5. If the exhaust temperature is not within specified limits, access the machine control electronics. See Accessing & Removing the Electronic Assemblies, page 7. Remove the P2 connector, then measure the resistance between P2-5 (red-white wire) and P2-6 (black wire) at the connector. See figure 12, page 7 for connector location.

**NOTE:** All thermistor resistance measurements must be made while dryer is unplugged or disconnected from power.

The following table gives temperatures and ranges for their associated resistance values.

THERMISTOR RESISTANCE			
TEMP. °F (°C)	RES. k Ω	TEMP. °F (°C)	RES. k Ω
50° (10°)	19.0–22.0	80° (27°)	8.5–10.5
60° (16°)	14.8–16.8	90° (32°)	6.8–8.8
70° (21°)	11.5–13.5	100° (38°)	5.0–7.0

- If the thermistor resistance does not agree with table, replace the thermistor.
- If the thermistor resistance checks agree with the measurements in the table, replace the machine control electronics.

**TEST #3b Thermal Fuse**

1. Unplug dryer or disconnect power.
2. Access the thermal fuse by first removing the toe panel. See Removing the Toe Panel, page 7; and figure 8, page 4 for thermal fuse location.
  - The thermal fuse is wired in series with the dryer drive motor. If the thermal fuse is open, replace it.

**TEST #3c Thermal Cut-Off**

If the dryer does not produce heat, check the status of the thermal cut-off.

1. Unplug dryer or disconnect power.
2. Access the thermal cut-off by first removing the toe panel. See Removing the Toe Panel, page 7.

3. Using an ohmmeter, check the continuity across the thermal cut-off. See figure 8, page 4 for location.
  - If the ohmmeter indicates an open circuit, replace the failed thermal cut-off and high limit thermostat. In addition, check for failed heat element, or blocked or improper exhaust system.

**TEST #4 Moisture Sensor**

**NOTE:** This test is started with the machine completely assembled.

This test is performed when an automatic cycle stops too soon, or runs much longer than expected.

**NOTE:** Dryer will shut down automatically after 2½ hours.

The following items are part of this system:

- Harness/connection
- Metal sensor strips
- Machine control electronics See ESD information, page 1.

1. Enter the diagnostic test mode. See procedure on page 1.
2. Open the dryer door. If a beep tone is heard and a software revision number is displayed on the console as soon as the door is opened, a short circuit exists in the moisture sensor system.

- If this doesn't happen, go to step 3.
- Otherwise, go to step 4.

**NOTE:** Over drying may be caused by a short circuit in the sensor system.

3. Locate the two metal sensor strips on the face of the lint screen housing. Bridge these strips with a wet cloth or finger.
  - If a beep tone is heard and a software revision number is displayed on the console, the sensor passes the test. Go to step 4.
  - If not, unplug dryer or disconnect power.
  - Access the moisture sensor wires by removing the toe panel. See Removing the Toe Panel, page 7. Disconnect the sensor wires from the harness. See figure 9. Go to step 8.

4. Unplug dryer or disconnect power.
5. Access the machine control electronics. See Accessing and Removing the Electronic Assemblies, page 7. Remove the P2 connector from the circuit board. Measure the resistance across terminals 1 (yellow-red wire) and 2 (black wire).
  - If the ohmmeter does not indicate (infinity) open circuit, go to step 6.
  - Otherwise, measure the resistance across pins 1 and 2 of the P2 connector on the machine control board. If a resistance less than 1 MΩ is measured (with analog or digital ohmmeter), inspect the control board for any debris bridging these pins. If no debris, replace the machine control electronics.

6. Access the moisture sensor by removing the toe panel. See Removing the Toe Panel, page 7. Disconnect the sensor from the wire harness. See figure 9.

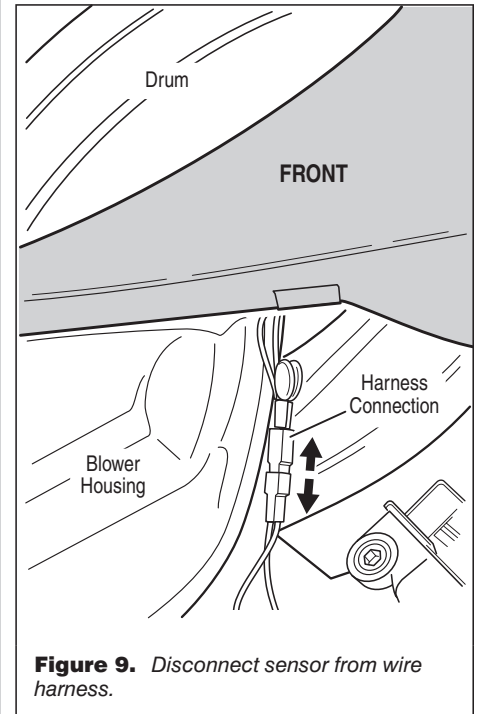

**Figure 9.** Disconnect sensor from wire harness.

7. Measure the resistance across the outermost contacts of the cable that includes the two red MOVs.
  - If a small resistance is measured, replace this component (wire harness, moisture sensor).
  - Otherwise go to step 8.
8. Measure the resistance across the pins of the mating connector. If a small resistance is measured here, replace this harness (digital wire harness).
9. Measure the resistance across each of the outermost contacts and the center terminal (ground connection).
  - If a resistance less than infinity is measured, replace this component (wire harness, moisture sensor).
10. If moisture sensor diagnostic test passes, check the thermistor: Perform TEST #3a, page 4.
  - If the problem persists after replacing the moisture sensor and thermistor, replace the machine control electronics.

## CHECKING FUNCTIONS OF BUTTONS AND ROTARY CYCLE SELECTOR

### CHECKING FUNCTIONS OF BUTTONS

Before replacing the machine control electronics, check for proper button function as follows:

- Unplug dryer or disconnect power.
- Disconnect the ribbon cables at P3 and P4 on the machine control electronics. See figure 12 on page 7 for connector locations.

The table at right show the pin locations of P3 and P4 connectors, one side at the board and the other side at the end of the ribbon cable. Insert meter leads into the DISCONNECTED RIBBON CABLE SIDE at the pin locations indicated in the table. Press the associated button and measure resistance.

BUTTON	DIGITAL METER		ANALOG METER	
	+ LEAD	- LEAD	- LEAD	+ LEAD
TEMP	P3-12	P3-8	P3-12	P3-8
EXTRA CARE	P3-13	P3-8	P3-13	P3-8
DRYNESS LEVEL	P3-14	P3-7	P3-14	P3-7
+	P3-13	P3-7	P3-13	P3-7
-	P3-12	P3-7	P3-12	P3-7
CYCLE END SIGNAL	P3-12	P4-2	P3-12	P4-2
HOLD TO START	P3-14	P4-2	P3-14	P4-2
OFF/Pause	P3-13	P4-2	P3-13	P4-2
CONTROL ON	P3-12	P3-9	P3-12	P3-9

**NOTE:** The meter must be connected with the proper polarity. For most analog meters, the connection polarity is opposite that of digital meters.

- *If using a digital meter:* the resistance reading should go from infinity down to about 1–3.5 M $\Omega$  (megohms). If available, you could use the “diode test” function of a digital meter, which will give a voltage of about .5–1.5 VDC during the test.
- *If using an analog meter:* the resistance reading should go from infinity (open circuit) to less than 40 k $\Omega$ . If not, reverse the polarities of the meter connection and measure the resistance again. If the reading is less than 40 k $\Omega$ , the circuit is OK and one should continue the remainder of the resistance checks with the connections reversed from that indicated in the table.

### CHECKING THE ROTARY CYCLE SELECTOR

One meter lead is always connected to P1-14.

- *With a digital meter:* the “+” lead is on P1-14.
- *With an analog meter:* the “-” lead is on P1-14.

Using the table at right, check the resistance at each cycle setting while the other lead of the meter is connected to P1-11, P1-10, P1-9, or P1-8.

CYCLE SELECTION	DIGITAL METER + LEAD ON P1-14				ANALOG METER - LEAD ON P1-14			
	P1-11	P1-10	P1-9	P1-8	P1-11	P1-10	P1-9	P1-8
Heavy Duty	$\infty$	$\infty$	$\infty$	$\infty$	$\infty$	$\infty$	$\infty$	$\infty$
Timed Dry	3.5 M $\Omega$	$\infty$	3.5 M $\Omega$	$\infty$	30–40 k $\Omega$	$\infty$	10–20 k $\Omega$	$\infty$
Touch Up	$\infty$	$\infty$	3.5 M $\Omega$	$\infty$	$\infty$	$\infty$	10–20 k $\Omega$	$\infty$
Rapid Dry	$\infty$	$\infty$	3.5 M $\Omega$	1.59 M $\Omega$	$\infty$	$\infty$	10–20 k $\Omega$	10–20 k $\Omega$
Super Delicate	$\infty$	1.58 M $\Omega$	$\infty$	290 k $\Omega$	$\infty$	10–20 k $\Omega$	$\infty$	10–20 k $\Omega$
Delicate	3.5 M $\Omega$	290 k $\Omega$	$\infty$	290 k $\Omega$	10–20 k $\Omega$	10–20 k $\Omega$	$\infty$	10–20 k $\Omega$
Casual	3.5 M $\Omega$	$\infty$	$\infty$	290 k $\Omega$	30–40 k $\Omega$	$\infty$	$\infty$	10–20 k $\Omega$
Normal	$\infty$	$\infty$	$\infty$	290 k $\Omega$	$\infty$	$\infty$	$\infty$	10–20 k $\Omega$

### TEST #5 Button and LED

Refer to the Diagnostic Tests, page 1 and activate the diagnostic test mode. Check for the following situations:

- ✓ None of the LEDs light up
- ✓ A particular group of LEDs does not light up
- ✓ A single LED does not light up
- ✓ No beep sound is heard
- ✓ No dryer function is activated when a particular button is pressed
- ✓ E3 error code is displayed

#### None of the LEDs light up:

1. See Diagnostic Guide/Before servicing... on page 1.
  2. Visually check that connectors P3 and P4 are inserted all the way into the machine control electronics. See Accessing & Removing the Electronic Assemblies, page 7. If these connections are good, perform the checks described in Checking Functions of Buttons and Rotary Cycle Selector in box above.
- If this test passes, replace the machine control electronics.

→ Otherwise, replace the console electronics and housing.

#### A particular group of LEDs does not light up:

A group or combination of LEDs share a common electronic connection. If this connection is open, all of the LEDs in the group will be disabled. Replace the console electronics and housing.

#### A single LED does not light up:

Press the button or manipulate the dial associated with the LED several times. If the LED does not light up, the LED has failed. Replace the console electronics and housing.

#### No beep sound is heard:

If the associated LEDs do light up, it is possible that the beeper circuit has failed. Check button functioning before replacing the machine control electronics. See box above.

#### No dryer function is activated when a particular button is pressed:

If the associated LEDs do light up, it is possible that the machine control electronics has failed. Check button functioning before replacing the machine control electronics. See box above.

#### E3 error code is displayed:

If the E3 error code is displayed, there is a user interface or software mismatch. It is also possible that a component on the console electronics or the machine control electronics has failed. Check button functioning before replacing the machine control electronics. See box above.

### TEST #6 Door Switch

Go into the diagnostic test mode. See page 1. Functionality is verified with a beep each time the door is closed and opened and an alpha numeric code appears in the display (0E, 0g 1E, or 2E etc.).

- If any of the above conditions are not met, or if one of the dryer model codes listed above is displayed when the door is closed, check that the wires between the door switch and machine control electronics are connected. See figure 10, page 7 for switch location; and see Accessing & Removing the Electronic Assemblies, page 7.

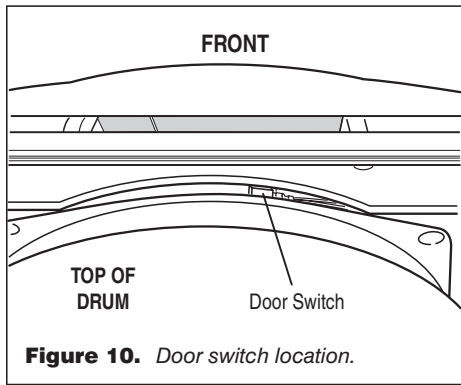

Figure 10. Door switch location.

- If the connections are OK, replace the wire and door switch assembly and retest.
- If wire and door assembly have been replaced and dryer still does not start, then replace the machine control electronics.

### REMOVING THE TOE PANEL

1. Unplug dryer or disconnect power.
2. Remove two screws below the toe panel.
3. Slide the toe panel down, then pull it out from the bottom. See figure 11.

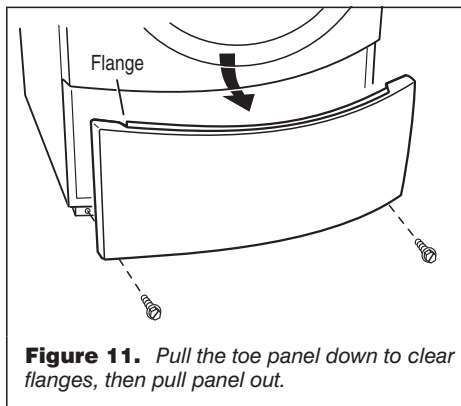
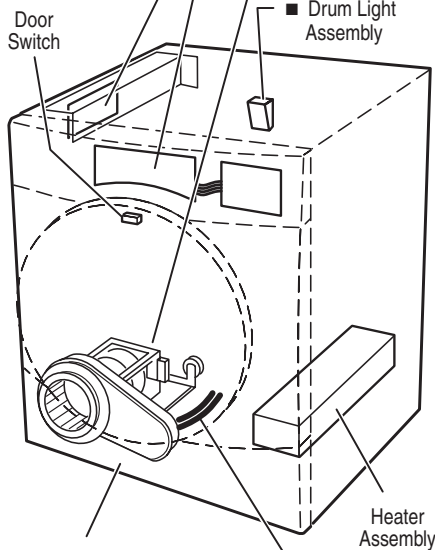

Figure 11. Pull the toe panel down to clear flanges, then pull panel out.

See Accessing & Removing the Electronic Assemblies to access:

- Console Electronics and Housing
  - Machine Control Electronics
- See Removing the Back Panel to access:
- Blower/Motor Assembly
  - Drum Light Assembly



See Removing the Toe Panel to access:

- Moisture Sensors
- Thermistor
- Thermal Cut-off
- Thermostat
- Heater Assembly

Figure 13. Component locations

### ACCESSING & REMOVING THE ELECTRONIC ASSEMBLIES

1. Unplug dryer or disconnect power.
2. Remove the top panel to access two electronic assemblies: the console electronics and housing; and the machine control electronics. See figure 14.

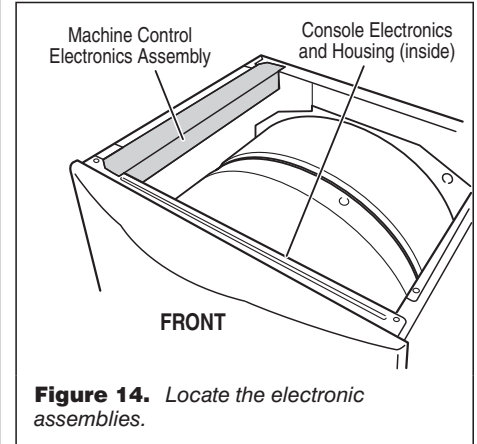

Figure 14. Locate the electronic assemblies.

### Machine Control Electronics

1. Perform steps 1 and 2 above, then remove the three screws that hold the machine control bracket in place and remove assembly. See figure 15.

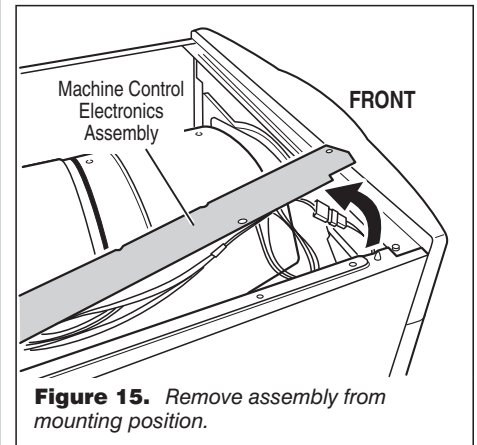

Figure 15. Remove assembly from mounting position.

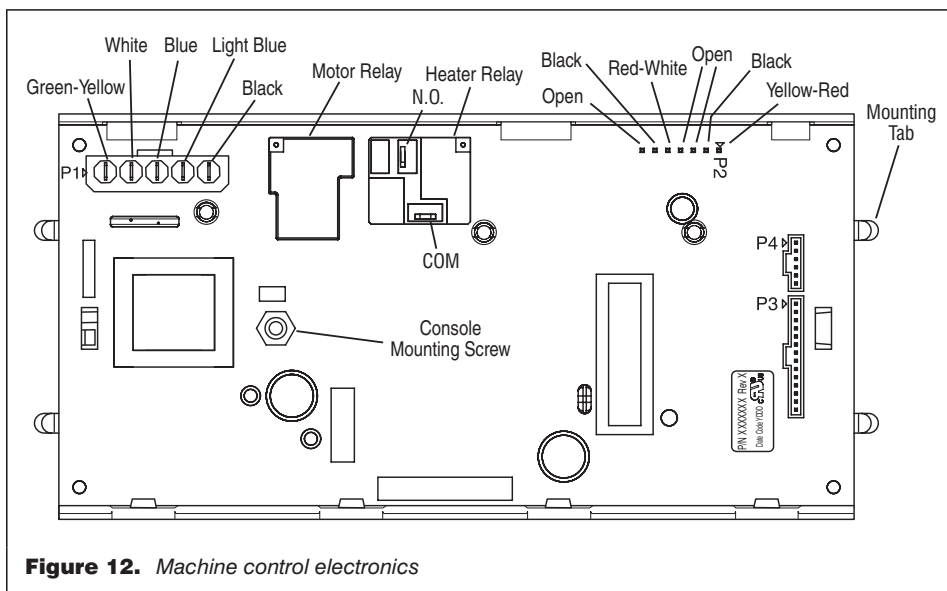
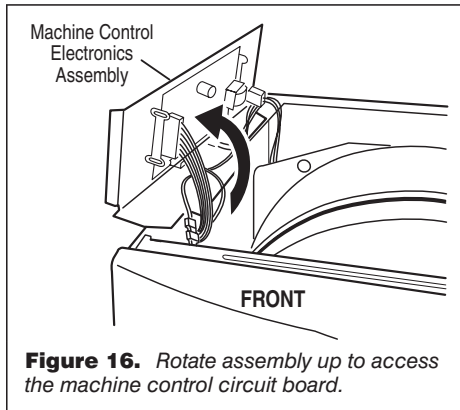

Figure 12. Machine control electronics

2. As you remove the assembly from its mounting position, rotate the assembly up to access the machine control circuit board, and set it on the side panel. See figure 16.

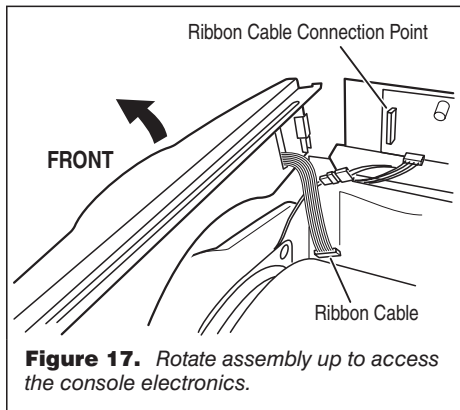

**Figure 16.** Rotate assembly up to access the machine control circuit board.

3. Remove all the wire connections to the machine control board. See figure 12, page 7.
4. Remove the console mounting screw, located near the transformer.
5. Press a side-end of the machine control electronics to release the mounting tabs at that end, then lift that end away from the bracket. Repeat to release the other side-end.

**Console Electronics and Housing**

1. Perform steps 1 and 2 under Accessing & Removing the Electronic Assemblies, page 7, then disconnect the ribbon cables that run between the console and the machine control board. Make the disconnection at the machine control side. Remove the two screws that fasten the console assembly to dryer, then remove the console assembly, sliding it up and off from the front of the machine. See figure 17.



**Figure 17.** Rotate assembly up to access the console electronics.

2. Remove the screws that fasten the console mounting bracket onto the assembly. Lift up and remove the bracket to locate the electronics assembly. See figure 18.

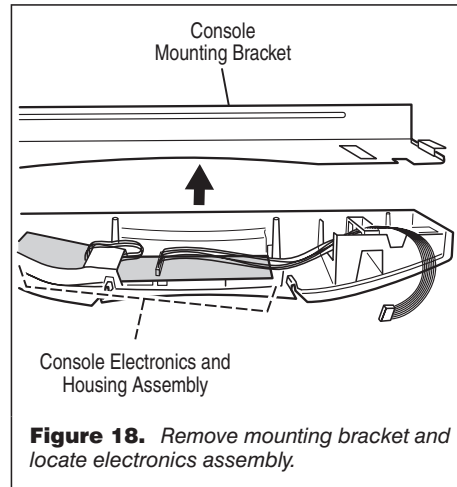

**Figure 18.** Remove mounting bracket and locate electronics assembly.

3. The console electronics and housing assembly is held to the decorative piece by seven plastic latches. See figure 19.

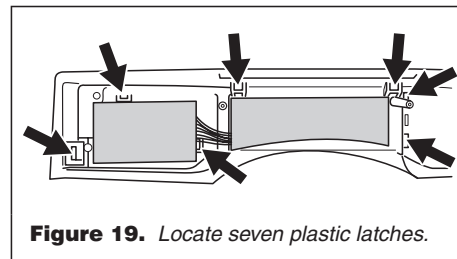

**Figure 19.** Locate seven plastic latches.

4. Unlatch them gently with a screw driver while pulling the electronics housing assembly out. See figure 20.

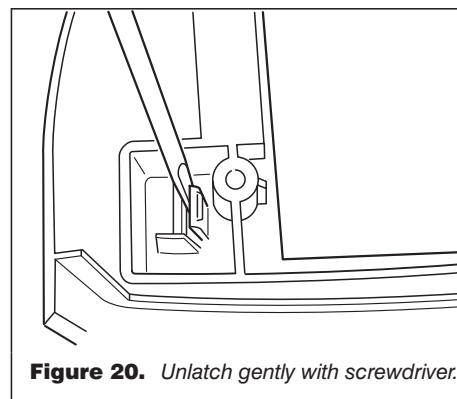

**Figure 20.** Unlatch gently with screwdriver.

5. Gently pull the console electronics housing away from the decorative piece. See figure 21.

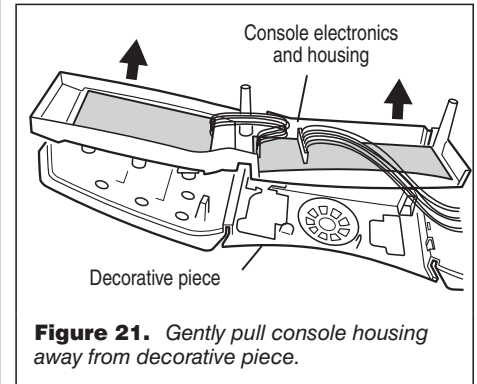

**Figure 21.** Gently pull console housing away from decorative piece.

**REMOVING THE BACK PANEL**

1. Unplug dryer or disconnect power.
2. After removing the top panel, remove the cover plate.
3. Remove ten screws plus the ground wire and ground screw from the back panel.
4. Remove two screws on the back panel's top edge, which connect the back panel to the side panels' top edges. See figure 22.
5. Disconnect the power cord from the terminal block, then remove the terminal block from the back panel.

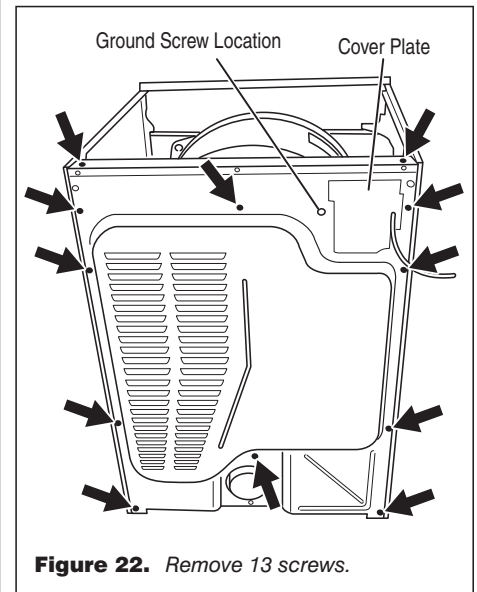

**Figure 22.** Remove 13 screws.

SOFTWARE COPYRIGHTED.  
MANUFACTURED UNDER ONE OR MORE  
OF THE FOLLOWING U.S. PATENTS:

4669200	4989347	6446357	D314261
4700495	5066050	6597144	D314262
4754556	5560120	6604298	D457991
4840285	5809828	6685241	D457992
4865366	6020698	6732447	D495453
4899464	6047486	6784673	
4908959	6199300	6819255	