



⚠ WARNING

Electrical Shock Hazard

Disconnect power before servicing.

Replace all panels before operating.

Failure to do so could result in death or electrical shock.

DIAGNOSTICS

Before servicing, perform the following checks:

- The most common cause for control failure is corrosion on connectors. Therefore, disconnecting and reconnecting wires will be necessary throughout test procedures.
- All tests/checks should be made with a VOM or DVM having a sensitivity of 20,000 ohms per volt DC or greater.
- Check all connections before replacing components, looking for broken or loose wires, failed terminals, or wires not pressed into connectors far enough.
- Voltage checks **must** be made with all connectors **attached** to the boards.
- Resistance checks **must** be made with power cord unplugged from outlet, and with wiring harness or connectors **disconnected**.

PROBLEM: Bake Temperature Needs Adjustment

1. Select which oven is to be adjusted by pressing the UPPER OVEN or LOWER OVEN pad.
2. Press BAKE pad for 5 seconds. The default temp. 0° or a previously entered offset temperature will show in the Temperature Display.
 - Press the TEMP pad “up” arrow (⬆) to increase the temperature in 10° F or 5° C increments.
 - Press the TEMP pad “down” arrow (⬇) to decrease the temperature in 10° F or 5° C increments.

Maximum offset temperature adjustment is ±30° F or ±15° C.
3. Press the START pad to save the temp. adjustment.

Fahrenheit (° F) to Celsius (° C) Conversion

The default is Fahrenheit (° F).

1. Press the BROIL pad for 5 seconds. The temperature will be displayed in degrees Celsius indicated by the “C” in the temperature display.
2. To return the display to degrees Fahrenheit press the BROIL pad again for 5 seconds. “F” will show in the temperature display.

IMPORTANT

Electrostatic Discharge (ESD) Sensitive Electronics

ESD problems are present everywhere. ESD may damage or weaken the electronic control assembly. The new control assembly may appear to work well after repair is finished, but failure may occur at a later date due to ESD stress.

- Use an anti-static wrist strap. Connect wrist strap to green ground connection point or unpainted metal in the appliance
-OR-
Touch your finger repeatedly to a green ground connection point or unpainted metal in the appliance.
- Before removing the part from its package, touch the anti-static bag to a green ground connection point or unpainted metal in the appliance.
- Avoid touching electronic parts or terminal contacts; handle electronic control assembly by edges only.
- When repackaging failed electronic control assembly in anti-static bag, observe above instructions.

Programming the Cavity Size

When replacing the electronic control, be sure to program the cavity size:

1. Within 60 seconds of power up, press the following touchpads:
LOWER OFF, UPPER OVEN, BAKE, TEMP DOWN, TIMER OFF, MINUTE DOWN, START, CLOCK, LIGHT.
2. Size is shown in display - “ID 24”.
3. Press CLOCK pad until correct size is displayed.
4. Press CANCEL.
5. Press and hold LOWER OFF pad for 5 seconds to verify programming.

NOTES:

- Always disconnect power before touching internal parts of the oven!
- Upon replacement, immediately return old electronic oven control using the mailing label supplied with each new control.
- For double ovens, the failure code is displayed on the side of the display that corresponds to the oven with faulty part (upper oven = left side of display).

FAILURE/ERROR DISPLAY CODES

FAULT CODE	ERROR CODE	CODE EXPLANATION	RECOMMENDED REPAIR PROCEDURE
F0		Default F code - no failure	Will only be displayed if user presses and holds "UPPER OFF" key for 5 seconds and there is no pre-existing fault. Press CANCEL to clear display.
F1	All E Codes	Electronic control malfunction	Replace control.
F2	E0	Key held down too long, or key is shorted	<ol style="list-style-type: none"> 1. Check keypad connector for firm connection. 2. Press CANCEL. If error code returns after 60 sec., replace keypad. 3. Replace control.
	E1	Keypad keytail not connected	
	E5 E6	CANCEL key drive line open	
F3	E0	Temperature sensor opened	<ol style="list-style-type: none"> 1. Check sensor connection. 2. Measure sensor resistance (1080Ω at 21° C (70° F). Add 2Ω per degree.) 3. If resistance is not valid, replace sensor. 4. If sensor resistance and connections are good, then the oven cavity temperature must have exceeded a safe level. Check for welded-closed relays on the control.
	E1	Temperature sensor shorted	
	E2	Oven temp too high - over 301° C (575° F) in COOK mode	
	E3	Oven temp too high - over 510° C (950° F) in CLEAN mode	
F4	E1	Meat probe malfunction - shorted	<ol style="list-style-type: none"> 1. Disconnect meat probe and measure probe resistance [78k Ω @ 15.6° C (60° F)];[37k Ω @ 32.2° C (90° F)]. 2. If resistance is not valid replace sensor. 3. Insert probe and check for a firm connection between probe and jack (in oven cavity). 4. Check connection between jack and harness (in rear of oven).
F5	E0	Door is open, but latch is locked (condition exists when door switch is closed indicating an open door, and latch switch is closed indicating a locked door)	<ol style="list-style-type: none"> 1. Check the latch assembly: latch arm pivot joint, arm/solenoid connection, solenoid spring, and spring washer. 2. Check the Latch Solenoid: <ul style="list-style-type: none"> - Check for firm electrical connections. - Disconnect the two wires from the solenoid and measure the resistance of the solenoid. A small resistance (approx. 175Ω) is normal. If the solenoid is open (∞Ω) or shorted (0Ω), it should be replaced. 3. Check the Latch Switch. Disconnect it and use a continuity tester: <ul style="list-style-type: none"> - Door latched = switch closed, continuity should read 0Ω. - Door unlatched = switch open, continuity should read ∞Ω. 4. Check Door Open/Closed Switch. Disconnect it and use a continuity tester: <ul style="list-style-type: none"> - Door open = switch closed, continuity should read 0Ω. - Door closed = switch open, continuity should read ∞Ω. 5. Check power and element connections.
	E1	Self-clean latch will not lock	
	E5	Self-clean temperature 288° C (550° F) not reached within 45 min.	
	E7	Self-clean latch will not unlock	
F6	E0	Return line not connected	If switch pulse return line not connected, electronic control will display F6 within 60 seconds after power up. Replace control.

WIRE HARNESS SCHEMATIC

NOTES:

- When replacing the electronic control, be sure to program the cavity size. See "Programming the Cavity Size" on page 1.
- Dots indicate sensor connections or splices.
- Circuit shown in STANDBY/OFF mode with oven door closed.

GROUND (CHASSIS)	AC DRIVE MOTOR	SOLENOID
PLUG WITH FEMALE CONNECTOR	RELAY COIL	ENCLOSED THERMISTOR
RECEPTACLE WITH MALE CONNECTOR	RELAY CONTACTS	OPERATED BY DOOR
LIGHT	HEATING ELEMENT	THERMAL FUSE/T.O.D.

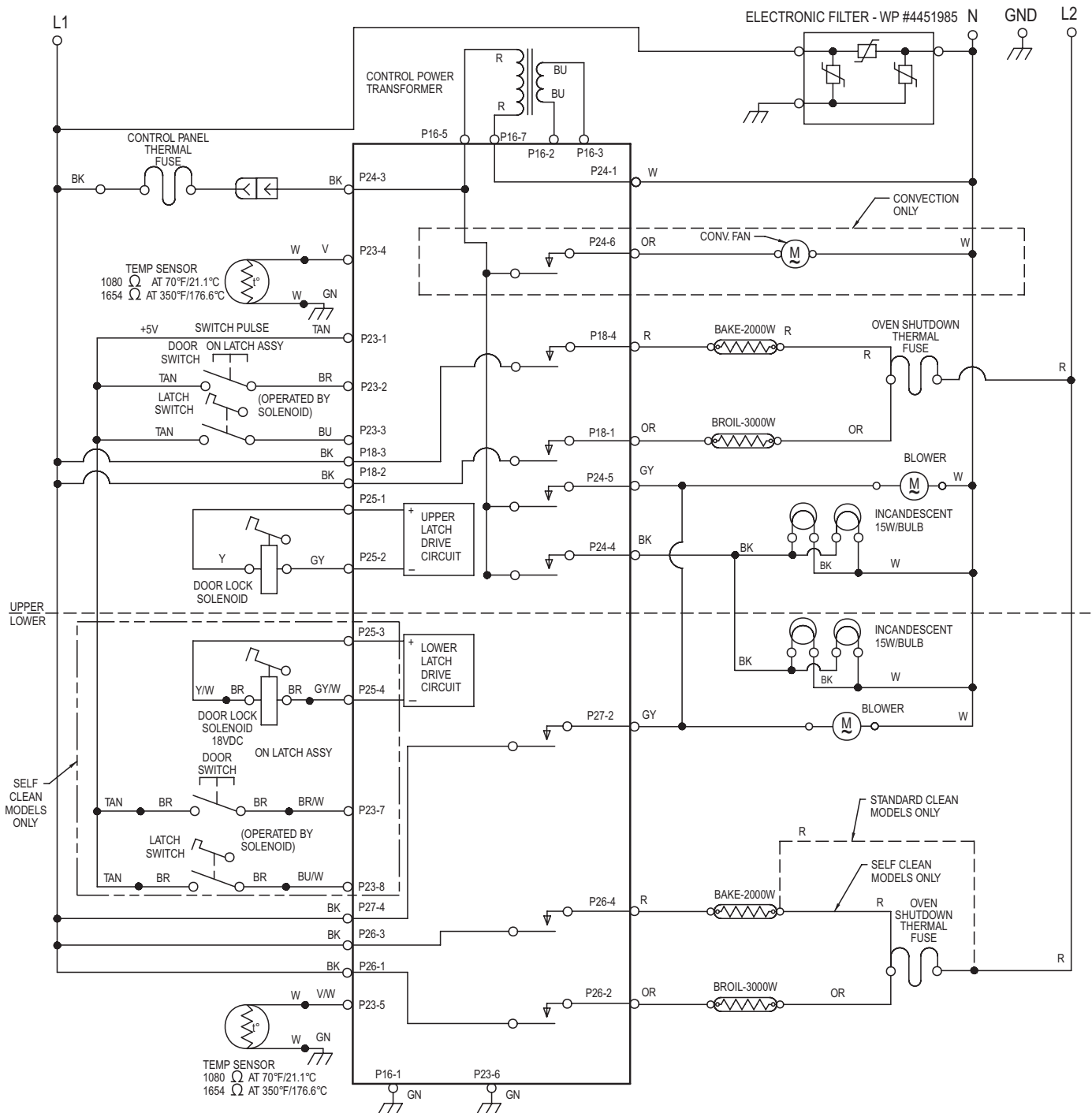

OVEN STRIP CIRCUITS

The following individual circuits are for use in diagnosis.
Before starting diagnosis, check the line voltage and for blown fuses.

NOTES:

- Pin numbers and wire colors shown in parentheses () denote lower oven connections.
- Pins denoted as * see wire harness schematic on page 3 for routing configuration from relays to L1.

BAKE AND PREHEAT-BAKE

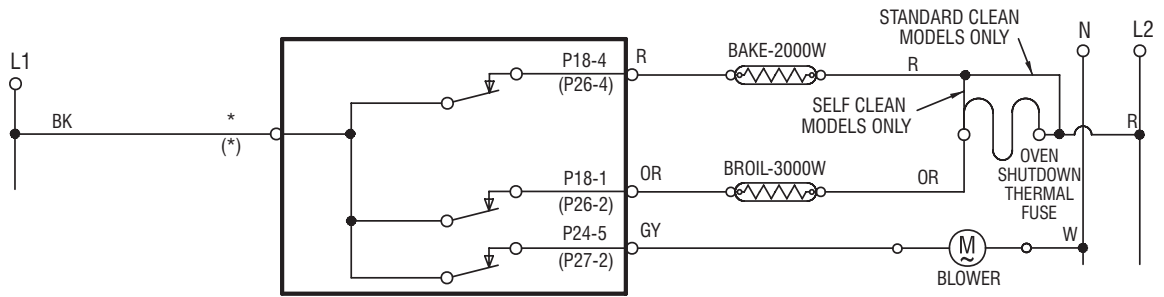

BROIL

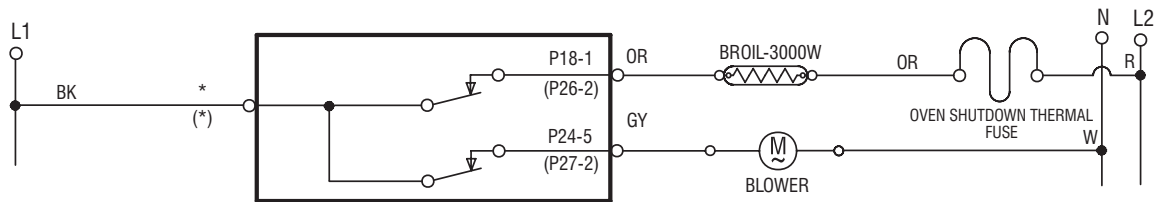

CONVECTION AND PREHEAT-CONVECTION

(CONVECTION MODELS, UPPER OVEN ONLY)

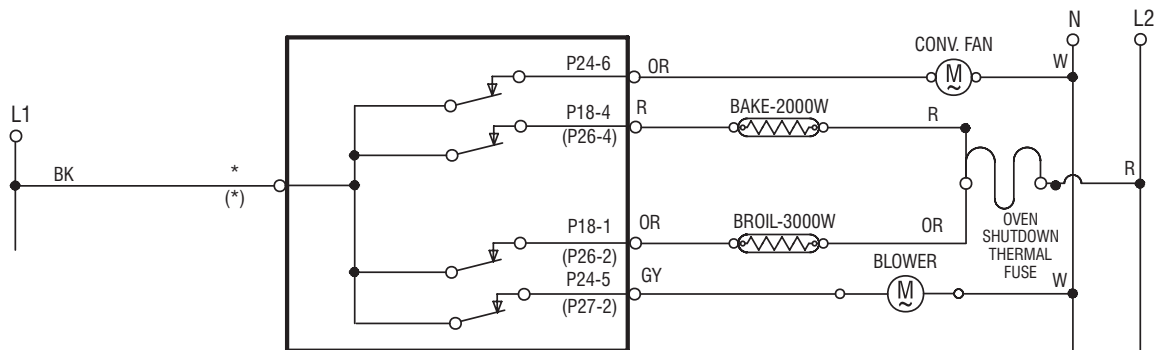

CLEAN AND PREHEAT-CLEAN

(SELF CLEAN MODELS ONLY)

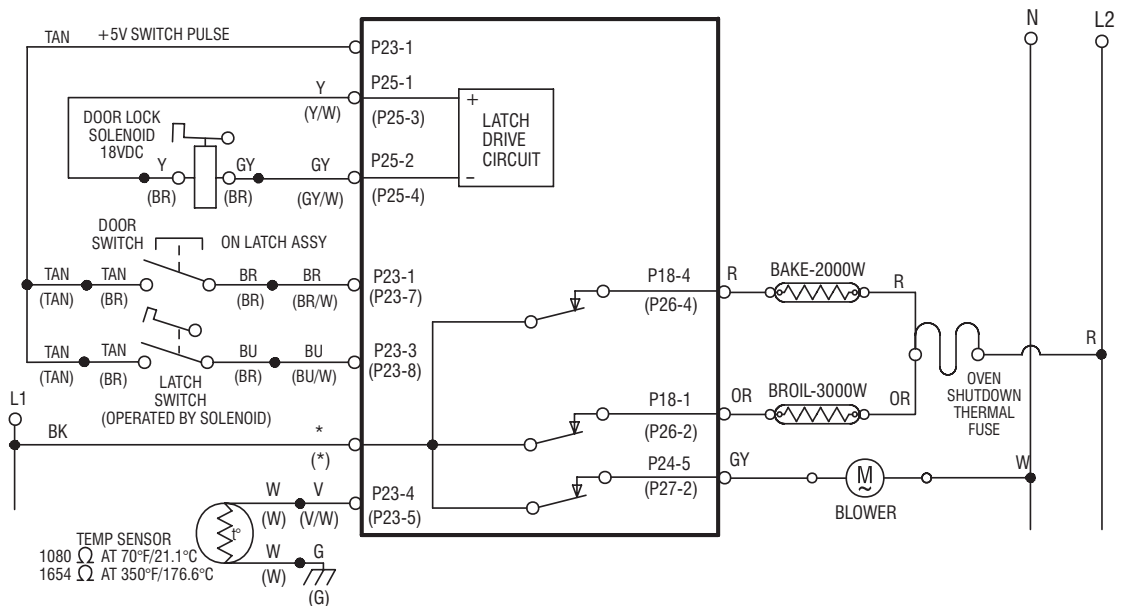

UPPER OVEN COMPONENTS

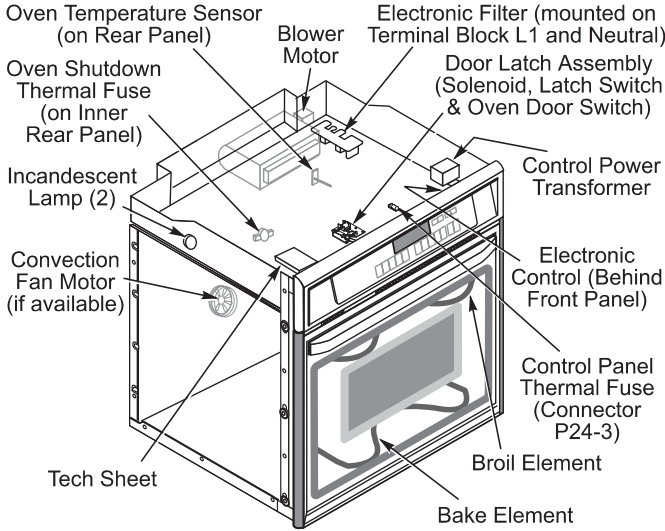

LOWER OVEN COMPONENTS

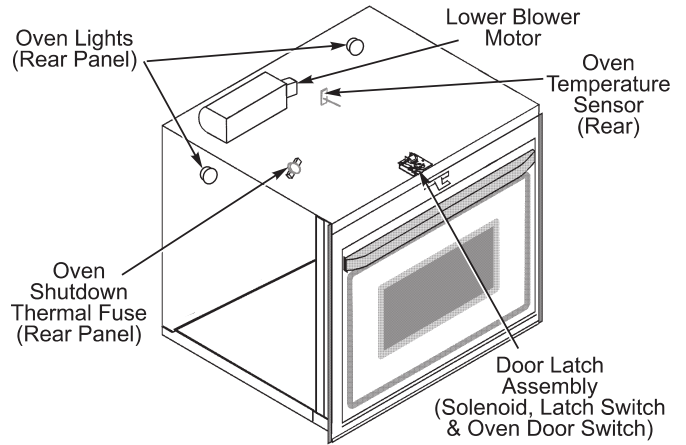

ELECTRONIC CONTROL PINOUTS

PIN	FUNCTION	COLOR
P24-1	NEUTRAL	W
P24-2	NOT CONNECTED	-
P24-3	L1	BK
P24-4	OVEN LIGHT	BK
P24-5	UPPER BLOWER	GY
P24-6	UPPER CONVECTION FAN	OR
P23-1	SWITCH COMMON	TAN
P23-2	UPPER DOOR SWITCH	BR
P23-3	UPPER LATCH SWITCH	BU
P23-4	UPPER OVEN SENSOR	VT
P23-5	LOWER OVEN SENSOR	VT/W
P23-6	GROUND	GR
P23-7	LOWER DOOR SWITCH	BR/W
P23-8	LOWER LATCH SWITCH	BU/W
P25-1	UPPER LATCH SOLENOID (+)	Y
P25-2	UPPER LATCH SOLENOID (-)	GY
P25-3	LOWER LATCH SOLENOID (+)	Y/W
P25-4	LOWER LATCH SOLENOID (-)	GY/W
P25-5	NOT CONNECTED	-
P16-1	GROUND	GN
P16-2	TRANSFORMER SECONDARY	BU
P16-3	TRANSFORMER SECONDARY	BU
P16-4	NOT CONNECTED	-
P16-5	TRANSFORMER PRIMARY	R
P16-6	NOT CONNECTED	-
P16-7	TRANSFORMER PRIMARY	R
P27-1	NOT CONNECTED	-
P27-2	LOWER BLOWER	GY
P27-3	NOT CONNECTED	-
P27-4	L1	BK
P18-1	UPPER BROIL	OR
SQUARE	-	-
P18-2	L1	BK
P18-3	L1	BK
P18-4	UPPER BAKE	R
P26-1	L1	BK
ROUND	-	-
P26-2	LOWER BROIL	OR
P26-3	L1	BK
P26-4	LOWER BAKE	R

ELECTRICAL COMPONENTS KEY

OVEN COMPONENT	FRONT / REAR SERVICEABLE
ELECTRONIC CONTROL	FRONT
MEMBRANE SWITCH	FRONT
DOOR SWITCHES	FRONT
LATCH SWITCHES	FRONT
LATCH SOLENOIDS	FRONT
OVEN TEMPERATURE SENSORS	FRONT
CONSOLE BLOWERS	REAR
INCANDESCENT LIGHTS	LIGHT BULB - FRONT LIGHT ASSY. - REAR
CONVECTION FAN MOTOR	REAR
T.O.D.	REAR
BAKE ELEMENTS	FRONT
BROIL ELEMENTS	FRONT
OVEN SHUTDOWN THERMAL FUSE	REAR
CONTROL PANEL THERMAL FUSE	FRONT
CONTROL POWER TRANSFORMER	FRONT
FILTER BOARD	FRONT

RELAY LOGIC UPPER AND LOWER OVEN

MODES	RELAYS	BAKE & "B"	BROIL & "BR"	CONV FAN	OV LT	BLOWER
OFF	0	0	0	0	0	0
■ PREHEAT-BAKE	+	+	0	0	0	X
BAKE 24", 27"	+	+	0	0	0	X
BAKE 30"	■	X	+	0	0	X
BROIL 24"	0	+	0	0	0	X
BROIL 27", 30"	0	X	0	0	0	X
● PREHEAT-CONV	X	+	X	0	0	X
CONV ●	+	+	X	0	0	X
▲ PREHEAT-CLEAN	+	+	0	0	0	X
CLEAN ▲	X	+	0	0	0	X

RELAY LOGIC KEY

- 0 - OFF
- X - ON
- + - CYCLING
- 0/ X - ON OR OFF

OVEN SHUTDOWN THERMAL FUSE

The oven shutdown thermal fuse is located at the back of the oven. It will shut down the elements if the temperature at the back of the oven exceeds component limits.

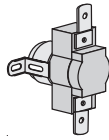

Verify that the oven shutdown thermal fuse is okay.

To replace this thermal fuse, refer to chart at right for correct part number.

Thermal Fuse Part No.	Opening Temp. ° C	Reclose Temp. ° C	Marking (with Black Letters)
4452223	130°C ± 5.5° C	-35° C MAX	Pink/Wht Stripe
4451442	120° C + 10° C to 120° C - 0° C		Yellow/Wht Stripe
4450934	170° C ± 6.5° C		Red
4450334	135° C ± 6.5° C		Orange/Wht Stripe
4450250	160° C ± 6.5° C		Blue
4450249	150° C ± 6.5° C		Green/Wht Stripe

LOWER OVEN			
COMPONENTS	FRONT/REAR SERVICEABLE	CHECK POINTS	RESULTS
Door Switch	Front	P23-7 (BR/W) to P23-1 (TAN)	Door Open = Closed Circuit Door Closed = Open Circuit
Door Lock Solenoid	Front	P25-3 (Y/W) to P25-4 (GY/W)	80 Ω to 100 Ω
Oven Temperature Sensor	Front	Sensor P23-5 (V) to P23-6 (GN)	1080 Ω @ 70°F
Blower	Rear	P27-2 (GY) to Neutral (W)	10 Ω to 15 Ω
Oven Shutdown Thermal Fuse	Rear	P26-2 (OR) or P26-4 (R) to Red Wire at Terminal Block	Closed Circuit
Bake Element	Front	P26-4 (R) to Red Wire at Terminal Block	25 Ω to 30 Ω
Broil Element	Front	P26-2 (OR) to Red Wire at Terminal Block	45 Ω to 55 Ω
Latch Switch	Front	P23-8 (BU/W) to P23-1 (TAN)	Door Unlocked = Open Circuit Door Locked = Closed Circuit

UPPER OVEN			
COMPONENTS	FRONT/REAR SERVICEABLE	CHECK POINTS	RESULTS
Door Switch	Front	P23-2 (BR) to P23-1 (TAN)	Door Open = Closed Circuit Door Closed = Open Circuit
Door Lock Solenoid	Front	P25-1 (Y) to P25-2 (GY)	80 Ω to 100 Ω
Oven Temperature Sensor	Front	Sensor P23-4 (V) to P23-6 (GN)	1080 Ω @ 70°F
Blower	Rear	P24-5 (GY) to Neutral (W)	10 Ω to 15 Ω
Oven Shutdown Thermal Fuse	Rear	P18-4 (R) or P18-1 (R) to Red Wire at Terminal Block	Closed Circuit
Bake Element	Front	P18-4 (R) to Red Wire at Terminal Block	25 Ω to 30 Ω
Broil Element	Front	P18-1 (OR) to Red Wire at Terminal Block	45 Ω to 55 Ω
Convection Fan Motor	Rear	P24-6 (OR) to Neutral (W)	8 Ω to 12 Ω
Control Panel Thermal Fuse	Front	L1 (BK) to P24-3 (BK)	Closed Circuit
Latch Switch	Front	P23-3 (BU) to P23-1 (TAN)	Door Unlocked = Open Circuit Door Locked = Closed Circuit
Control Transformer	Front	Primary Winding P16-5 (R) to P16-7 (R) Secondary Winding P16-2 (BU) to P16-3 (BU)	75 Ω to 95 Ω 2 Ω to 4 Ω

PART NO. 4451887 REV. C

NOTE: This sheet contains important Technical Service Data

**FOR SERVICE TECHNICIAN ONLY
DO NOT REMOVE OR DESTROY**

MANUFACTURED UNDER ONE OR MORE OF THE FOLLOWING UNITED STATES PATENTS:

4,102,322 4,364,589 4,467,184

OTHER PATENTS PENDING